

Avance Carestation 8.X

Participant Guide

Version A

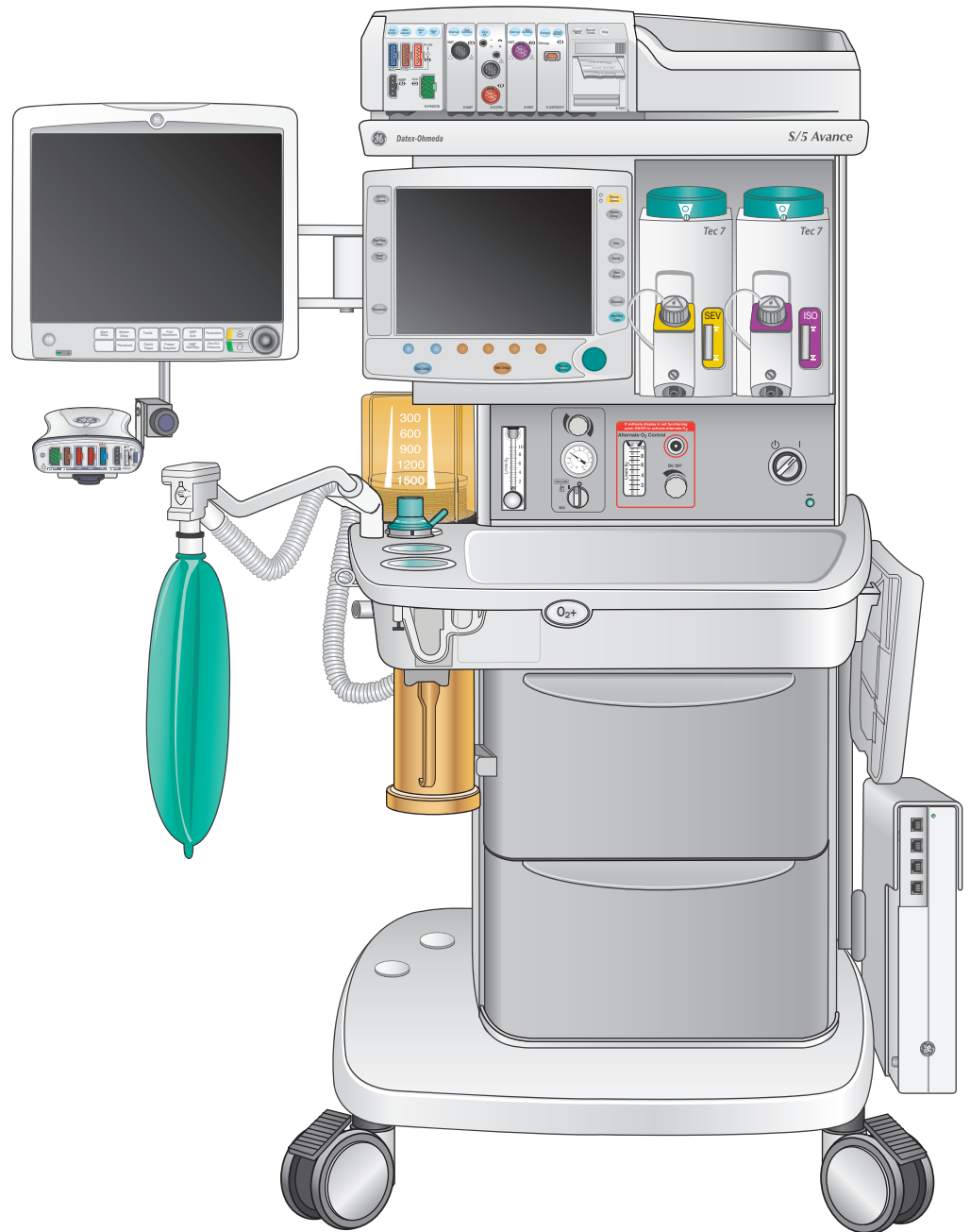

Avance Carestation 8.X

Participant Guide

Version A

Clinical Systems

Clinical and Educational Development

Customer Support Center: 800-345-2700

Notice

The materials contained in this document are intended for educational purposes only. This document does not establish specifications, operating procedures or maintenance methods for any of the products referenced. Always refer to the official written materials (labeling) provided with the product for specifications, operating procedures and maintenance requirements.

Proprietary Training Material Property of GE Healthcare. The materials contained in this document are intended for educational purposes only. Use of these materials is limited to agents and employees of GE Healthcare or other parties expressly licensed by GE. Unlicensed use is strictly prohibited. These materials may include clinical concepts and definitions. No diagnostic statements are inferred or included in these materials. All clinical diagnosis should be made by a trained physician or clinician.

All patient names or other protected health information or data contained in any image within this material is fictitious. Any similarity to actual persons is coincidental.



Note! *This participant guide is not intended to replace the User's Reference Manuals that you received with the machine. Please refer to the disclaimer notice at the end of this participant guide for more information.*

This course is intended for Avance software level 8.X. The material contained in this course is intended for educational purposes only. Always refer to the official written materials provided with the Avance Carestation for specifications, operating procedures, and maintenance requirements.

Contents

1 Welcome	1.1	Tec 6 & 6 Plus:	4.4
Class Description	1.1	Tec 6 & 6 Plus Filling	4.5
Class Objectives	1.2	Tec 7 and Easy-Fil™ Adapters	4.6
2 Overview	2.1	5 Advanced Breathing System	5.1
Avance Overview	2.1	Bag/Vent Switch	5.2
Front View	2.2	APL Valve	5.2
Side View	2.4	Bag Support Arm	5.3
Back View	2.6	Absorber Canister	5.4
Anesthesia Display Overview	2.8	Canister Access on a Standard Machine	5.5
Display Components	2.8	Canister Access on a Machine with the EZchange Mode	5.6
System Power	2.10	Condenser	5.7
System Switch	2.10	Flow Sensors	5.8
Battery Capacity	2.10	Preventing Moisture Buildup	5.9
O ₂ Information Sources	2.11	Auxiliary Common Gas Outlet (ACGO)	5.10
O ₂ Flush Button	2.13		
Alternate O ₂ Control	2.14	6 Operation	6.1
Electronic Gas Delivery System	2.15	The Start Case Menu	6.1
Types of Scavenging Systems	2.16	Start Case Settings	6.2
Passive AGSS	2.16	Start a Case With Default Settings	6.3
Active Systems	2.17	Minimum Alveolar Concentration (MAC)	6.4
		Ventilator Menus	6.5
 		Ventilator Modes and Settings	6.5
3 Display Navigation	3.1	Gas Setup	6.6
Using Menus and the ComWheel	3.1	Trends	6.7
Using Quick Keys	3.2	Cardiac Bypass	6.8
Main Menu	3.3	Alarm Management	6.10
Select Page	3.4	Overview	6.10
		Alarm Setup	6.10
 		Setting Alarm Limits	6.11
4 Vaporization	4.1		
Types, Mounting & Filling	4.1		
Selectatec Interlock Mounting System	4.2		
Tec 5 Filling	4.3		

12 Resources	12.1
Avance User Operational Maintenance Schedule.....	12.1
Avance Anesthesia Supplies and Accessories	12.2
Avance Quick Guide.....	12.3
Avance Troubleshooting Guide	12.5
13 Clinical Training Documents	13.1
Clinical Training Checklist.....	13.1
Avance Carestation Clinical Skills Checklist..	13.3
Clinical Training Quiz.....	13.5
Clinical Training Quiz Answer Sheet.....	13.8
14 Non-Clinical Training Documents	14.1
Avance Non-Clinical Training Checklist	14.1
Avance Carestation Non-Clinical Skills Checklist	14.3
Non-Clinical Training Quiz	14.4
Non-Clinical Training Quiz Answer Sheet.....	14.6
15 Evaluation	15.1

1 Welcome

We would like to take a moment to thank you for choosing GE Healthcare for your anesthesia Carestation needs. Our goal now is to provide you with the best training service available while continuing to support you as you use our products in your workplace.

Class Description

This course is designed to give Participants the information and product knowledge needed to proficiently operate the Avance Carestation. This class will use discussion, scenarios and return demonstrations. The application of problem-solving techniques will also be incorporated.

Participant Learning Objectives



After completing this training, the participant will be able to:

- Describe the main components of the Avance Carestation
- Power up the Avance Carestation and recognize when battery power is active
- Utilize the O₂ flush button
- Activate Alternate O₂ Control
- Adjust FiO₂ and Total Flow
- Describe the type of scavenging system utilized
- Navigate the display using the ComWheel and Quick Keys
- Access the multiple selections available from the Main Menu
- Access the Select Page menu and select a page
- Turn on and adjust agent level using a vaporizer
- Fill and change a vaporizer
- Utilize the Bag/Vent switch and the APL valve
- Remove and replace the CO₂ canister
- Drain the condenser, if applicable
- Zero the flow sensors
- Start a case from the Start Case menu.
- Enter a patient weight to calculate MAC value
- Access the Vent Setup menu and adjust settings
- Access the Gas Setup menu and adjust settings
- Access the Trends menu
- Activate the Cardiac Bypass mode
- Access the Alarm Setup menu and adjust an alarm limit
- Access multiple ventilation modes and describe the available modes of ventilation
- Save and view a loop from the Spirometry menu
- Utilize Pause Gas Flow, Vital Capacity and Cycling from the Procedures menu
- Perform a complete checkout
- Perform the tasks on the Avance Maintenance Schedule
- Access the Avance Troubleshooting Guide

2 Overview

Avance Overview

This chapter will take you on a tour of the Avance and help you get to know the main components you will be working with.

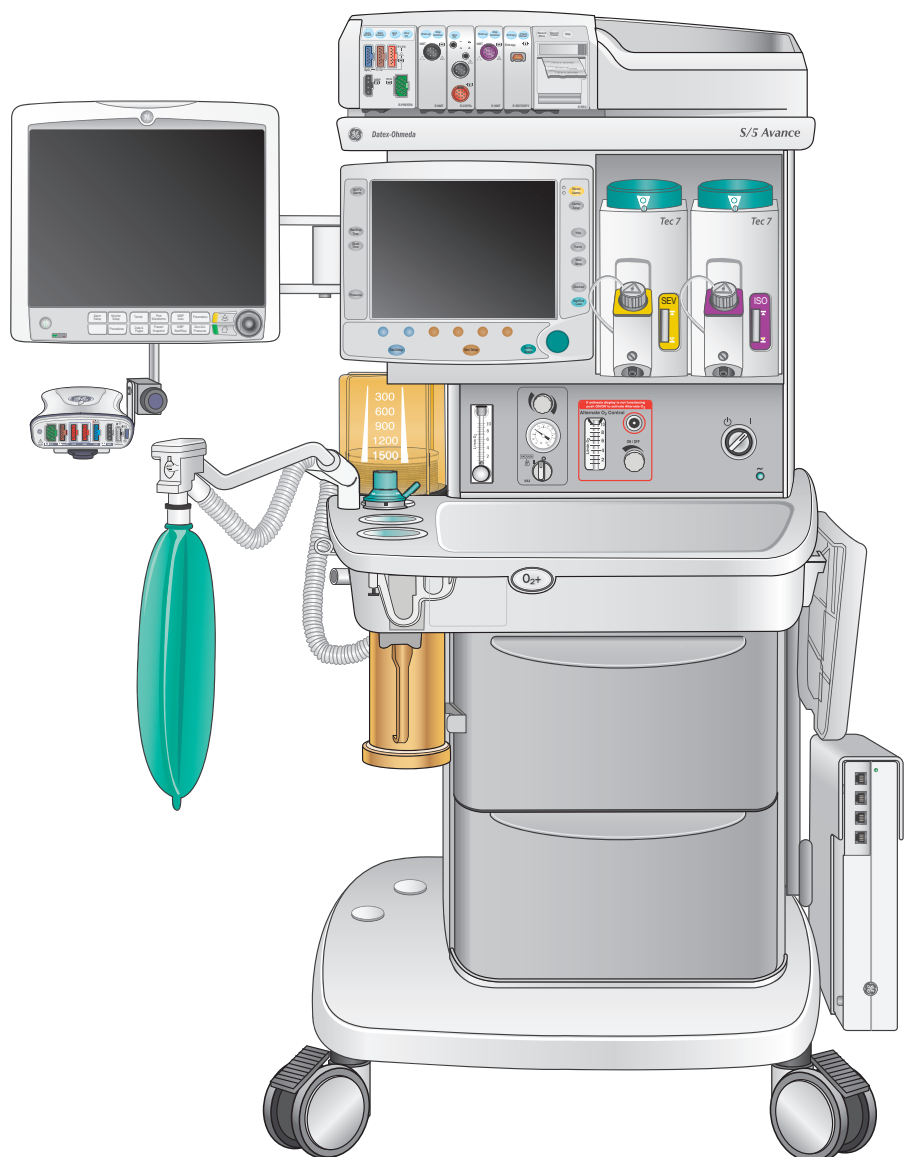

Front View

1. **Patient Monitoring Modules:** This storage bay is typically used to house the optional patient monitoring equipment rack.
2. **Anesthesia System Display:** This display is used to run the Avance. Since the Avance is an electronically controlled anesthesia system, the buttons and menu items on the display are used throughout the anesthesia delivery process. These functions range from prompting the user to perform checkout tests at startup to choosing ventilation parameters and setting alarms. The display provides real-time data on gas and airway flows as well as explanatory text for each menu selection.
3. **Vaporizers:** Avance uses the Tec series of vaporizers.
4. **Vacuum Controls:** These optional integrated suction controls let the clinician easily adjust the vacuum used to suction fluids from the patient during a case. The switch can be set to **max** for full vacuum, **Off** for no vacuum, or **On** for adjustable vacuum. When using the vacuum mode, the knob is turned clockwise to increase the vacuum and counterclockwise to decrease the vacuum.
5. **System Switch:** Located on the right hand side of the machine, the system switch turns on or off both the gas flow and the electronics.
6. **Alternate O₂ Control:** This component provides manual back-up control of oxygen delivery to the patient. The alternate O₂ control delivers oxygen through an independent pneumatic path connected to the system oxygen supply. In the event of a problem with the Avance electronic system or display screen, the alternate O₂ control activates automatically to allow the clinician to deliver oxygen manually.
7. **Brakes:** On each front wheel of the Avance you will find a brake to minimize movement of the machine.
8. **O₂ Flush Button:** Regardless of the position of the system switch (ON or Standby), oxygen is available at the O₂ flush button. This will serve to deliver a high concentration of oxygen to the breathing system, while inflating the bellows or re-breathing bag.
9. **Auxiliary O₂ Flowmeter:** The auxiliary O₂ flowmeter is an optional accessory. It is most often used to deliver oxygen through a nasal cannula. Oxygen is always available here; regardless if the machine is turned on or not.
10. **Patient Monitoring Display:** This optional display shows the data captured by the installed patient monitoring modules. Such data typically includes both depth of anesthesia and hemodynamic values.



Note! *The Patient Monitoring display could be mounted to the left of, or above, the anesthesia system display.*

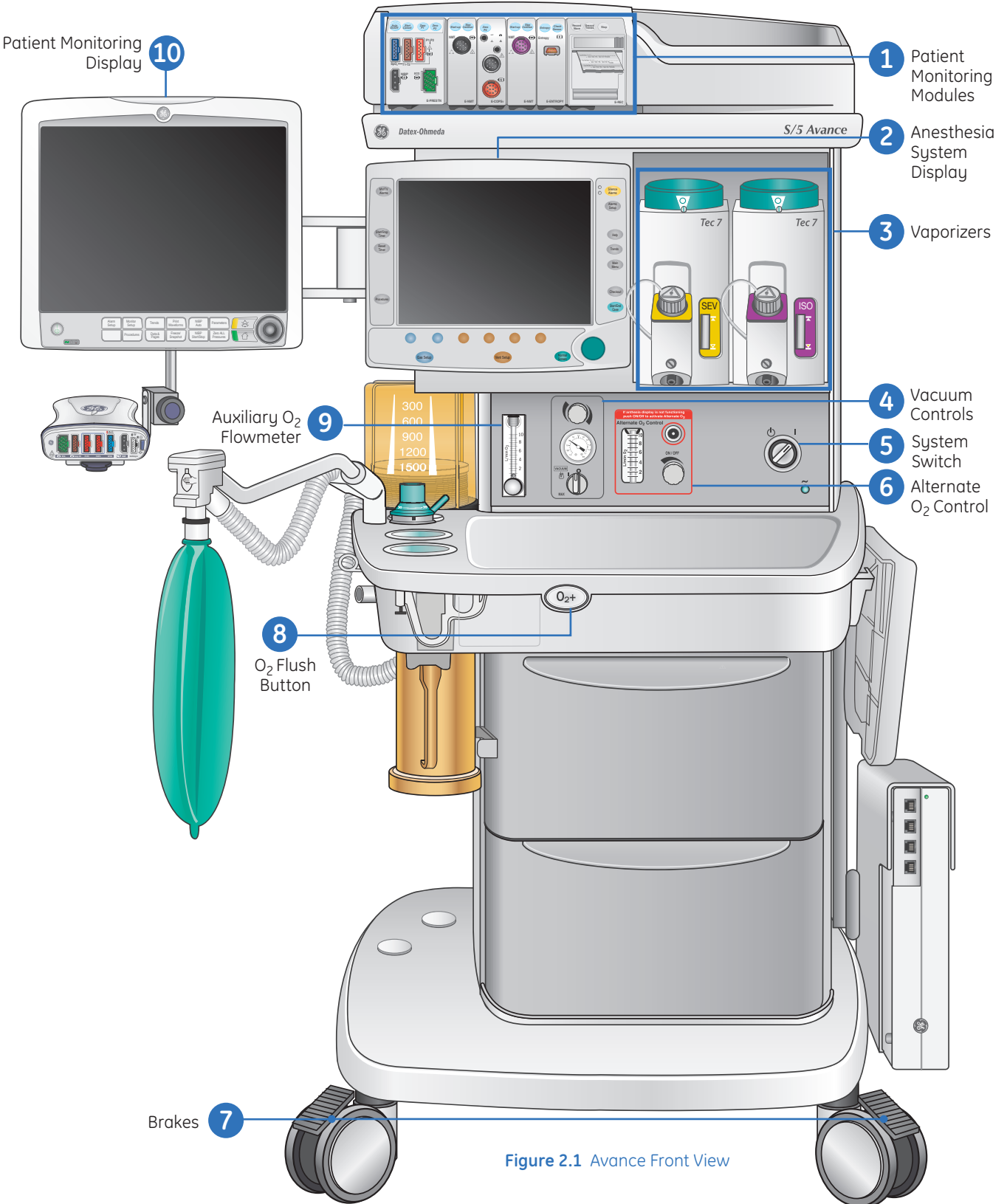

Figure 2.1 Avance Front View

Side View

- 1. Breathing System:** On the left-hand side of the Avance is the breathing system. The breathing system includes everything between the bellows and the absorber canister. The components within this portion of the machine are the ones that come into direct contact with the patient's breath.
- 2. Bellows Assembly:** There are two ways to deliver gas to the patient. One way is mechanically, through the use of the ventilator. In this case, the gases that are to be delivered to the patient are contained within the bellows assembly.
- 3. Bag Hose:** This hose connects the breathing system to the re-breathing bag. The length of the hose is mounted onto either a bracket or the optional bag arm.
- 4. Flow Sensors:** Protruding from the breathing system are the flow sensors. This is where the breathing circuit is connected to the machine. More importantly, the flow sensors are used to determine the volume of gas flowing to and from the patient.
- 5. Rebreathing Bag:** The second way to deliver gas to the patient is manually. The clinician squeezes the rebreathing bag, which contains a mixture of gases.
- 6. Absorber Canister:** This component removes carbon dioxide from the patient's exhaled breath. These *scrubbed* gases can then be sent back to the patient.
- 7. Scavenging Bag:** On adjustable scavenging systems, this three-liter bag is used to provide a visual confirmation that the scavenging vacuum is set properly.
- 8. Scavenging Connector:** Every Avance will have some sort of scavenging connector. The type of connector depends on the configuration of the operating room. Regardless of the connector style, a hose is hooked up to it in order to safely remove excess gas from the machine.
- 9. Airway Module:** The airway module measures and monitors gases delivered to the patient. Commonly referred to as the gas module, this component includes sensors for measuring carbon dioxide, nitrous oxide, anesthetic agents and oxygen. A gas sampling line attaches to the adapter on the breathing circuit.

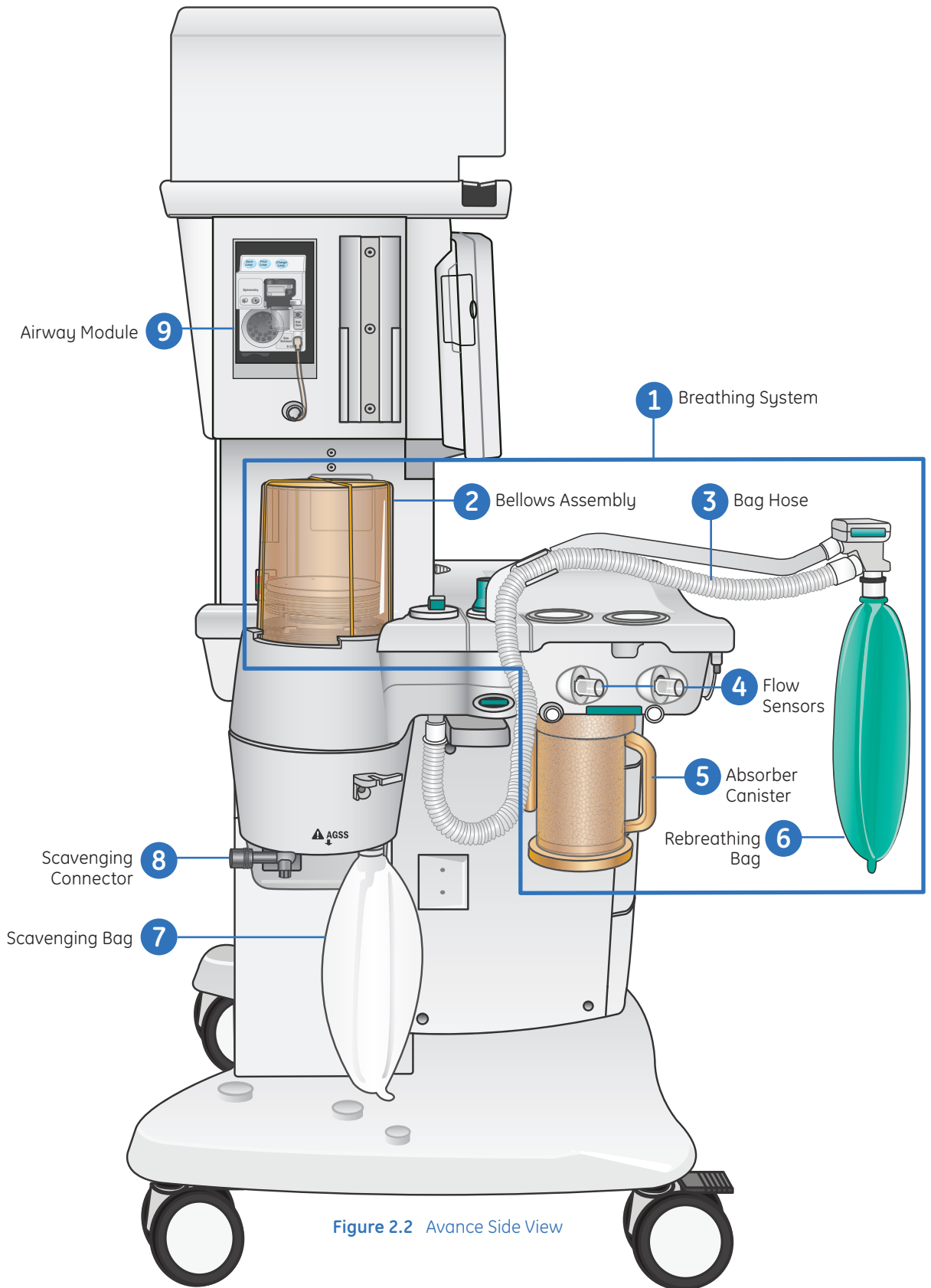

Figure 2.2 Advance Side View

Back View

- 1. Cylinder wrench (key) storage:** Storage for the cylinder key used to open and close the gas cylinders.
- 2. Collection Bottle:** The collection bottle is part of the optional suction accessory. In the event that fluids are drawn up into this bottle, they will be trapped here. When the fluid level reaches the bottom of the black turbine, it will float and thereby block the vacuum flow. This action will prevent the fluids from entering the suction regulator.
- 3. Cylinder Yokes:** Cylinders provide a source of gas for the anesthesia machine. The inboard cylinder yokes extend out of the back of the Avance so two cylinders can be mounted to the machine.
- 4. Cylinders:** Cylinders are used as a gas supply when the pipeline supply is unavailable. Two cylinders may be attached to the inboard cylinder yokes. Typically, one cylinder contains oxygen and the other contains oxygen, nitrous oxide or AIR.
- 5. Main Circuit Breaker:** On the bottom left side is a rocker switch. This is the main circuit breaker. It should not be mistaken for an on/off switch. Accidentally pressing this switch will cause the Avance to be powered by its reserve battery instead of electricity from the wall outlet.
- 6. Pipeline Inlets:** Hoses are connected between the pipeline inlets and the gas outlets in the operating room. This is another way that gas gets into the anesthesia machine.
- 7. Electrical Outlets:** The electrical outlets on the back of the Avance are a convenient place to plug in low power accessories that are used in conjunction with the anesthesia machine. This is one of the ways to help reduce the amount of cord clutter behind the Avance.



Note! *The electrical outlets are for low power only! Do not use these outlets for equipment such as blanket warmers and operating room beds.*

- 8. Circuit Breakers:** For each auxiliary power outlet.

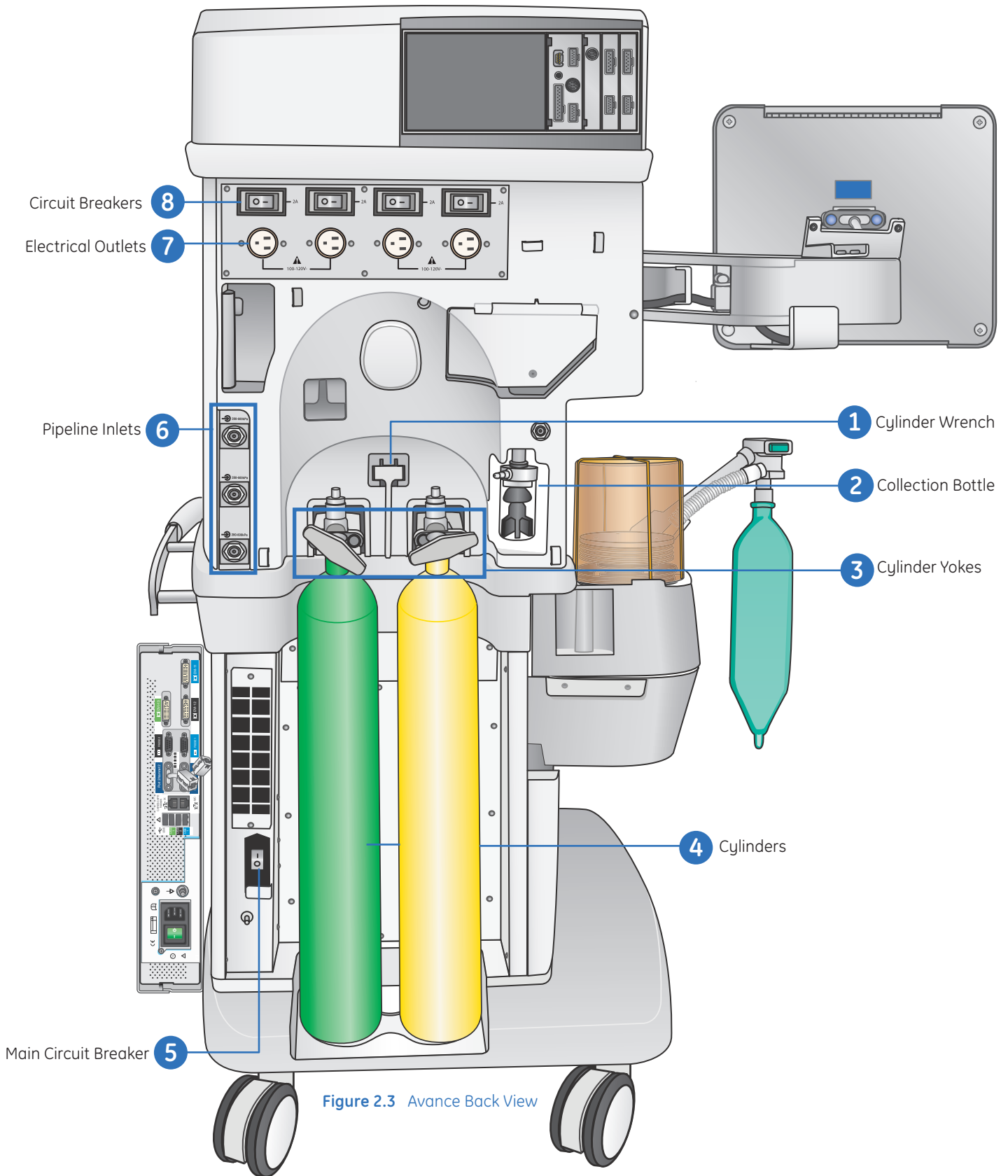

Figure 2.3 Avance Back View

Anesthesia Display Overview

Display Components

- 1. Display Screen:** Pressure, Flow and CO₂ waveforms/numerics.
- 2. Alarm LEDs:** Color and behavior indicates type of alarm.
- 3. Setup & Function Keys:** Push to access various menus and options.
 - a. Silence Alarms
 - b. Alarms Setup
 - c. Help
 - d. Trends
 - e. Main Menu
 - f. Checkout
 - g. Start/End Case
- 4. Patient Gas Monitoring/Pipeline and Tank Pressure:** During a case, patient respiratory data is displayed in this area of the screen. When in standby, the pipeline and tank pressures are present.
- 5. ComWheel:** Push to select a menu item or confirm a setting. Turn clockwise or counterclockwise to scroll menu items or change settings.
- 6. Normal Screen:** Push to enter back into normal view at any time.
- 7. Spirometry:** Allows you to directly access spirometry setup and settings.
- 8. Gas Settings:** Quick Keys and Menu to make changes to all ventilation options.
 - h. Vent Setup Key
 - i. Vent Quick Key
 - j. Ventilator Mode and settings
- 9. Gas Setup Controls:** Quick Keys and Menu to make changes to gas regulation and flow control.
 - k. Gas Setup Key
 - l. Gas Quick Keys
 - m. Gas Displays
- 10. Procedures:** Access the Procedures menu to pause the gas flow, perform or change the settings for a vital capacity procedure, or perform or change the settings for a cycling procedure.
- 11. Reset Timer:** Push to reset the timer back to zero.
- 12. Start/Stop Timer:** Push to start or stop the timer.
- 13. MV/TV Alarm:** Push to toggle the MV/TV alarm.
- 14. Fresh Gas Flows:** Electronic Gas Flow Indicator.
- 15. Airway Pressure Gauge:** A digital display for airway pressure, which can be configured from the Screen Setup menu.

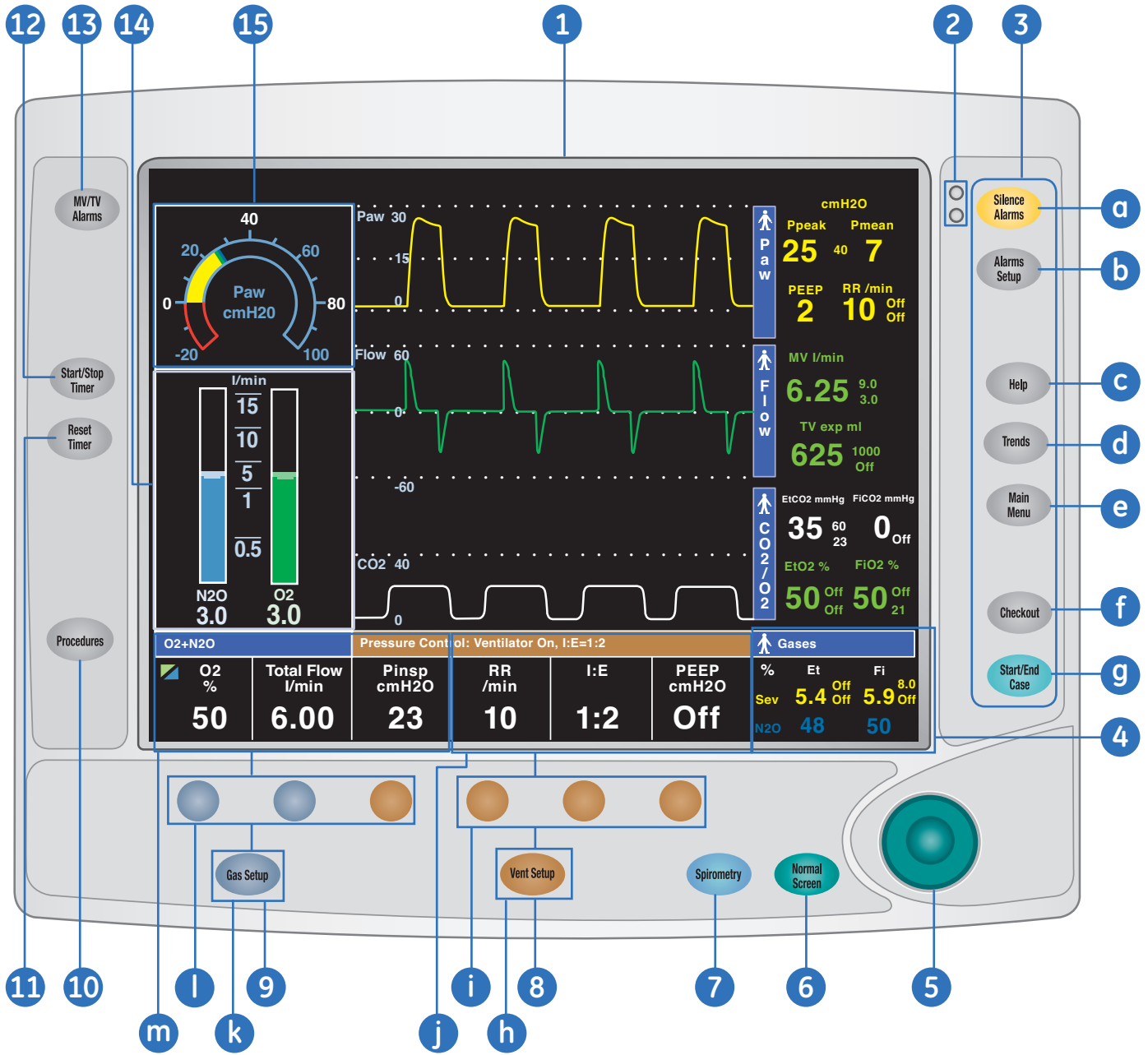

Figure 2.4 Anesthesia Display

System Power

System Switch

The system switch powers up the ventilator, ventilator screen and gas module. The mains indicator will come on when the AC power is connected. The patient monitor has a separate ON Switch.

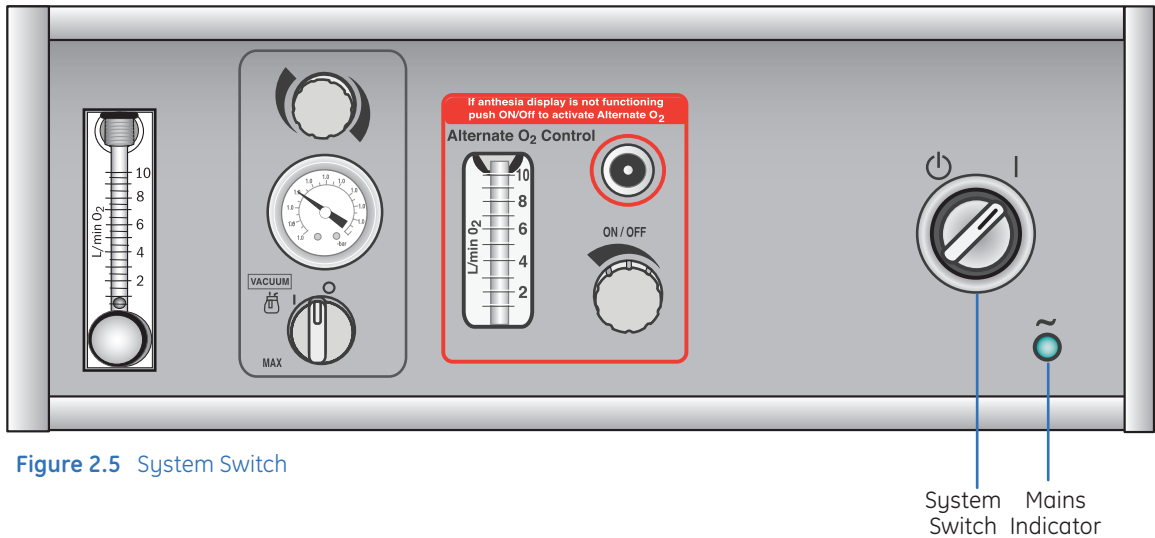

Figure 2.5 System Switch

Battery Capacity

The battery can provide power for a maximum of 1.5 hours when fully charged, depending on flow rates and ventilator settings. The average capacity of a fully charged battery is thirty to forty-five minutes. The battery will only provide power to the ventilator, the ventilator display and the gas module, not to the patient monitor.

The battery automatically charges when the machine is plugged in. The color and fill amount of the **Battery in Use** icon indicates the amount of battery power remaining.

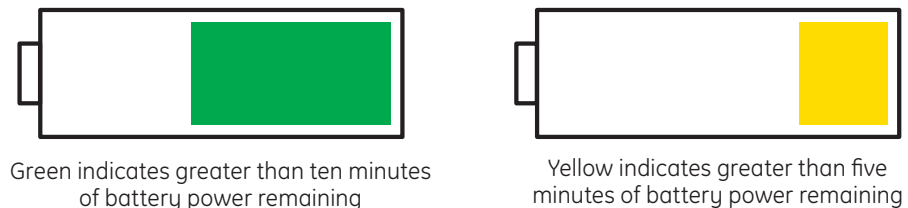

Figure 2.6 Battery Power

High priority alarms will trigger when the machine is running on battery power, when there is less than five minutes of battery power remaining, and when there is less than one minute of battery power remaining.

O₂ Information Sources

There are two sources of O₂ information available on the Avance.

The first source is the compact airway module. The compact airway module measures and monitors gases delivered to the patient and exhaled through the breathing circuit. The module consists of an infrared sensor for measuring CO₂, N₂O, and anesthetic agents; a paramagnetic O₂ sensor; and a gas sampling system with the D-fend water separation system. The compact airway module may also include the ability to measure spirometry.

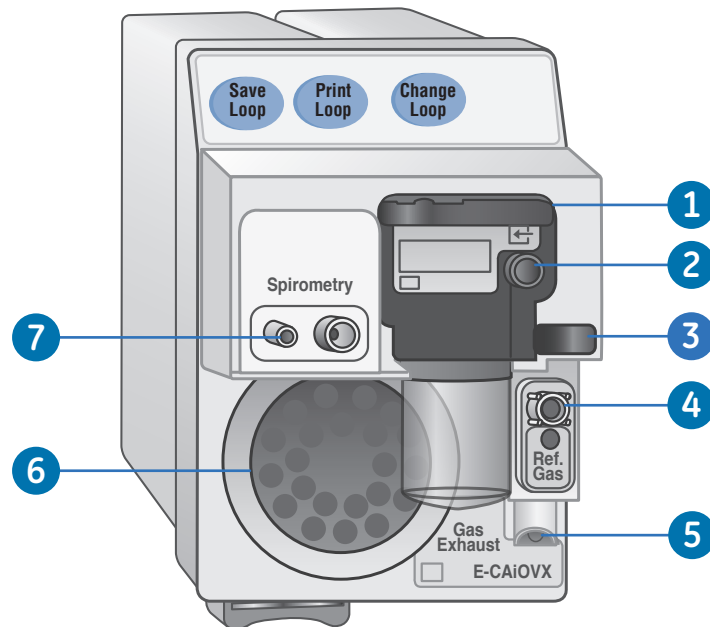

Figure 2.7 Compact Airway Module

1. D-fend water trap with washable container.
2. Sampling line connector on the D-fend water trap.
3. Water trap latch.
4. Oxygen reference gas inlet.
5. Sample gas outlet.
6. Cooling fan with dust filter.
7. Connectors for Patient Spirometry only.

The second source is an optional Galvanic Cell, or O₂ Sensor, located within the Advanced Breathing System (ABS). The Galvanic Cell measures the circuit O₂. The O₂ sensor is calibrated daily during the system checkout, and can be expected to last approximately eighteen months. It CANNOT be disinfected.

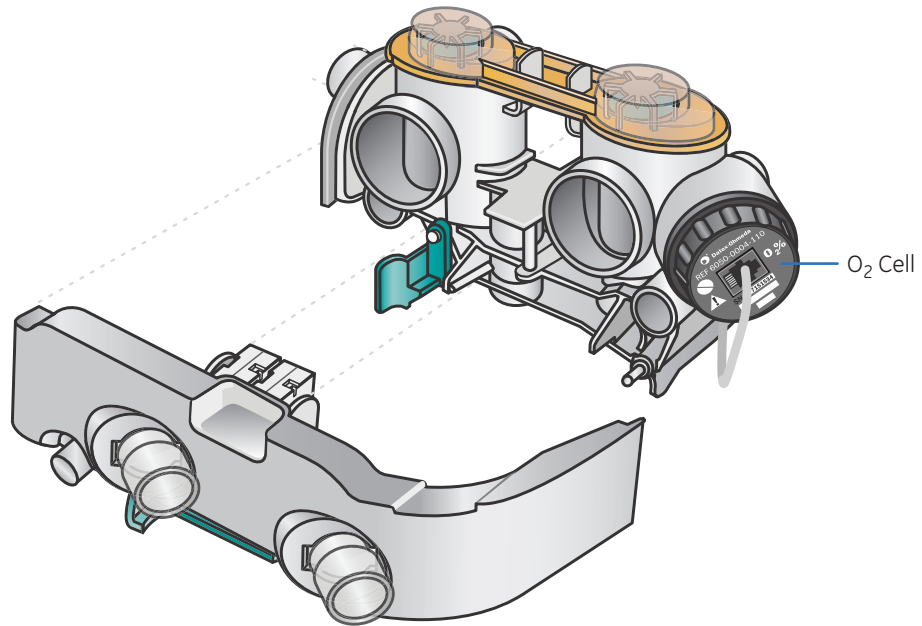

Figure 2.8 O₂ Sensor



Note! Systems with an airway gas module may not include the optional Galvanic Cell. Systems with both an airway module and an O₂ cell will display the patient inspired O₂ value obtained from the airway module.

O₂ Flush Button

The O₂ Flush Button delivers a high flow (35 - 50 L/min) of 100% O₂ to the breathing system, bypassing the vaporizers.

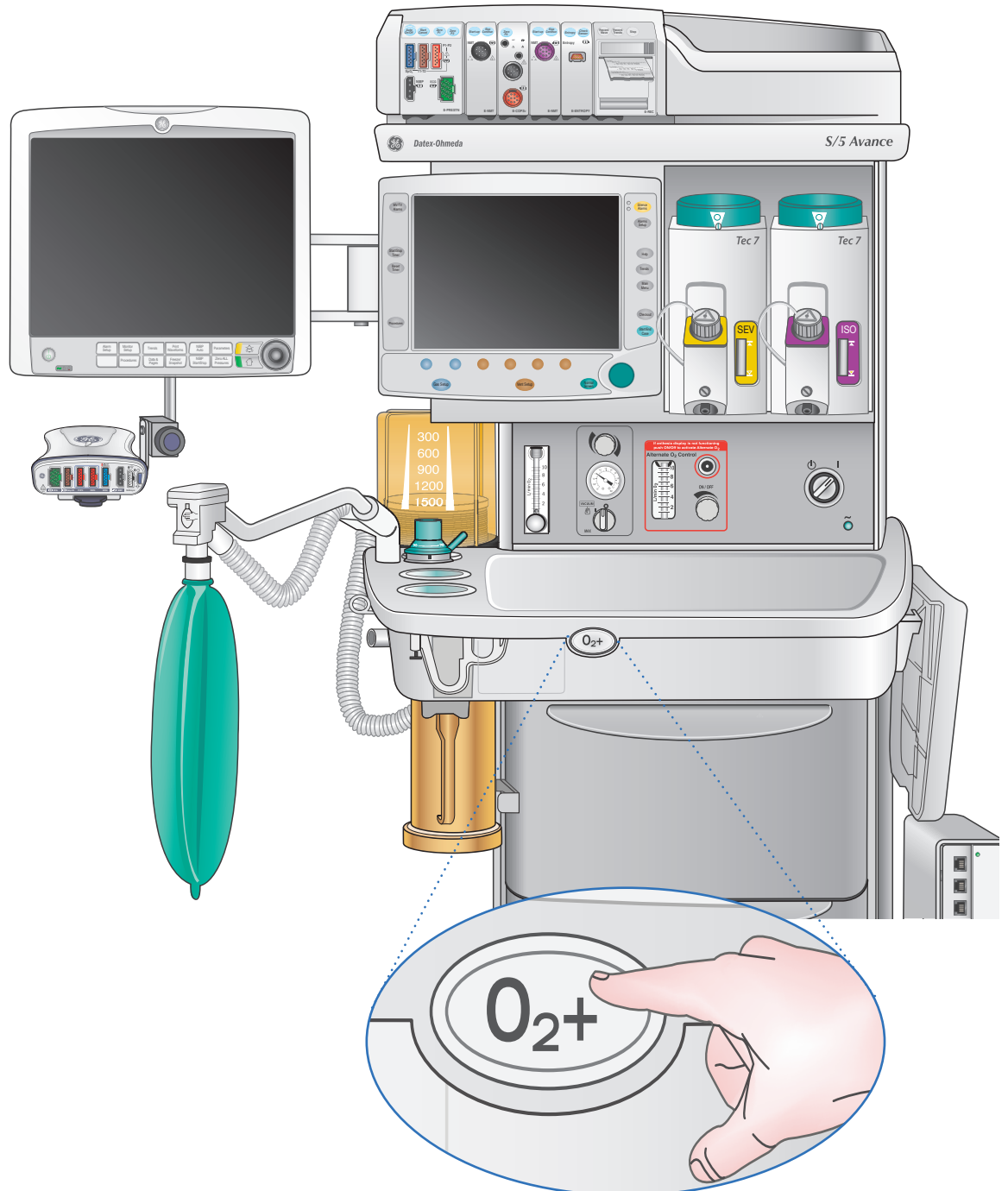
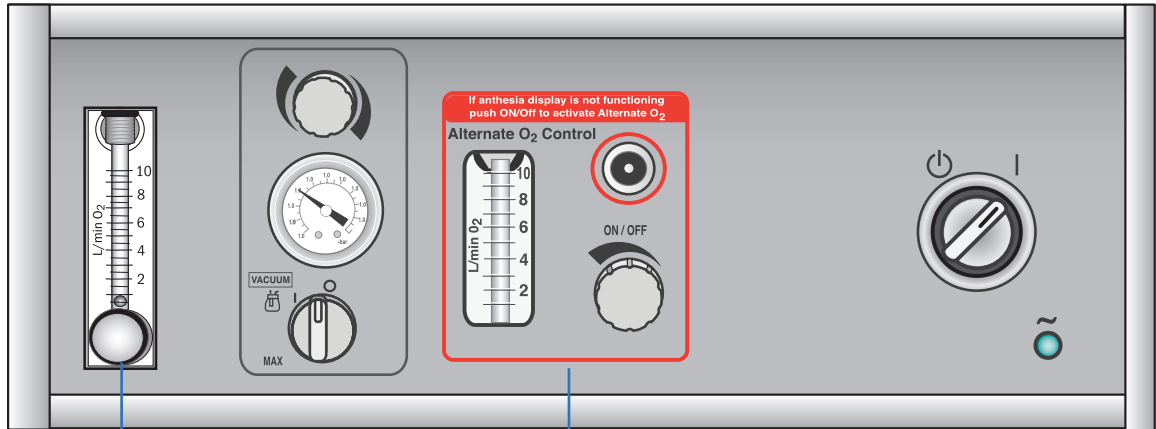

Figure 2.9 O₂ Flush Button

Alternate O₂ Control

The Alternate O₂ control delivers O₂ through an independent pneumatic path to the selected patient circuit and is connected to the system O₂ supply. It activates automatically in the case of certain failures or errors, and can continue to deliver O₂ without power. It can also be activated manually. O₂ flow is 0.5 L/min to 10 L/min as indicated on the flow tube. It is available approximately 20 seconds after the system is turned on.

Push the **Alternate O₂ ON/OFF** button to begin manually. When Alternate O₂ control is enabled, flow from the electronic mixer is stopped, and O₂ is flowing through the Alternate O₂ control to the breathing system. The O₂ and Total Flow Indicators on the monitor will be blank. The ventilator is available when Alternate O₂ is activated.



Auxiliary O₂ Flowmeter

Alternate O₂ Control

Figure 2.10 Avance Control Panel

You can return to normal functioning by pressing the **Alternate O₂ ON/OFF** button again. The Gas Setup menu will appear on the screen, along with the selection **End Alternate O₂**, which will have **Yes** already highlighted as it's selection. Confirm this selection by pressing the ComWheel. You will then return to the primary display and normal functioning, with 100% O₂ at two L/min.

Auxiliary O₂ Flowmeter

In addition to the Alternate O₂ control, there is an Auxiliary O₂ Flowmeter just above the work surface on the Avance, giving you the option of delivering O₂ through a nasal cannula or face mask.

Electronic Gas Delivery System

The Electronic Gas Mixer controls the ratio and flows of gases delivered to the Inspiratory Port of the patient circuit. You can select either O₂ and air or O₂ and N₂O through the Gas Setup Menu. To do this, press Gas Setup, and you can switch between air and N₂O while continuing to deliver anesthesia.

When utilizing the Avance, you will set a total liter flow and the concentration of O₂ you wish to deliver to the patient. This is slightly different from traditional anesthesia systems which allowed you to set flows independently of each other. Set total flow using the second Gray Quick Key. Set O₂ percent using the first Gray Quick Key.



Note! Traditional flow meter configuration is also available. This can be selected from the **Screen Setup/Fresh Gas Controls** menu. The Super User can set the default gas control style for the facility. The Fresh Gas Controls menu item may be blocked if set for the facility by the Super User.

The Avance also includes an electronic hypoxic guard to prevent the delivery of hypoxic mixtures in fresh gas flow, and features a 500 millisecond mixer response time, even during dramatic flow changes.

The flowmeters are electronic, and are displayed digitally. The electronic flowmeters are controlled through the Gas Setup buttons and are displayed digitally. The gas concentrations are controlled through the mixer. As mentioned before, you do not independently set the amount of gases delivered – instead, a total flow is selected, then concentration of O₂. If the Electronic Mixer or machine fails, O₂ will continue to flow through the use of the Alternate O₂ control.

There is a minimum FiO₂ of 25%, except when fresh gas flow is air only. In this case, the minimum FiO₂ is 21%. The analyzed values may be lower than the set values due to the addition of anesthetic agent.

Start of Case: The default O₂ concentration and O₂ flow can be configured to your facility's specification.

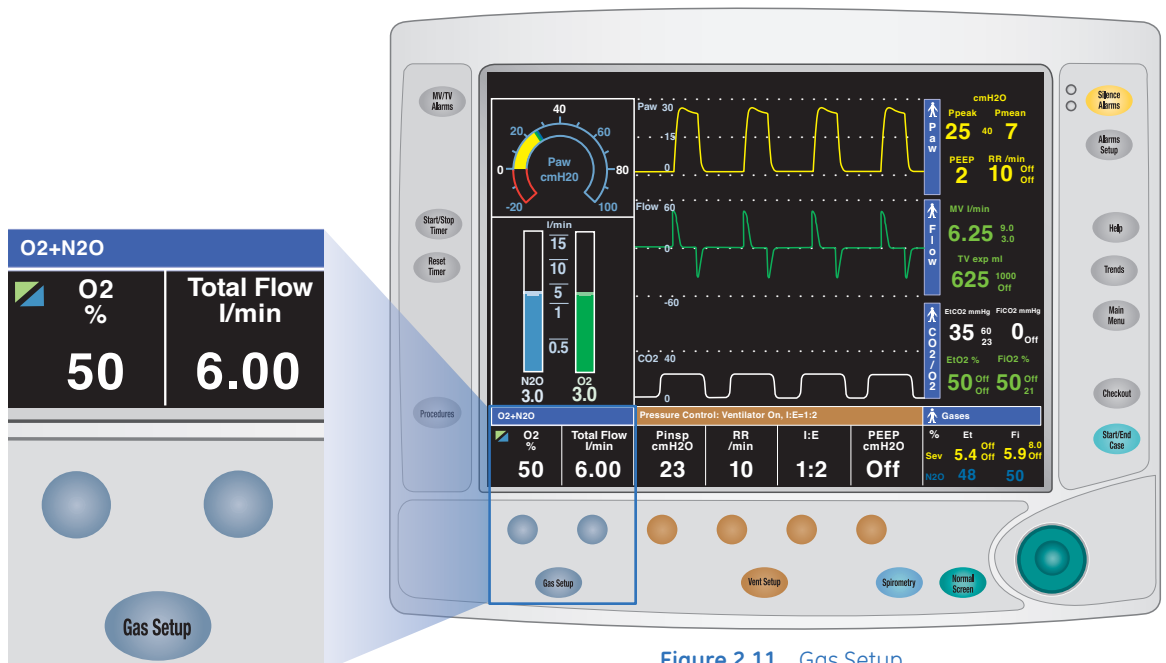

Figure 2.11 Gas Setup

Types of Scavenging Systems

Passive AGSS (Anesthetic Gas Scavenging System)

- Mainly used in operating rooms with no active gas extraction system for waste gas disposal
- Includes positive and negative pressure relief valves
- Outlet is a 30mm connector at bottom of scavenger
- Large tubing directly links the passive AGSS with building exterior

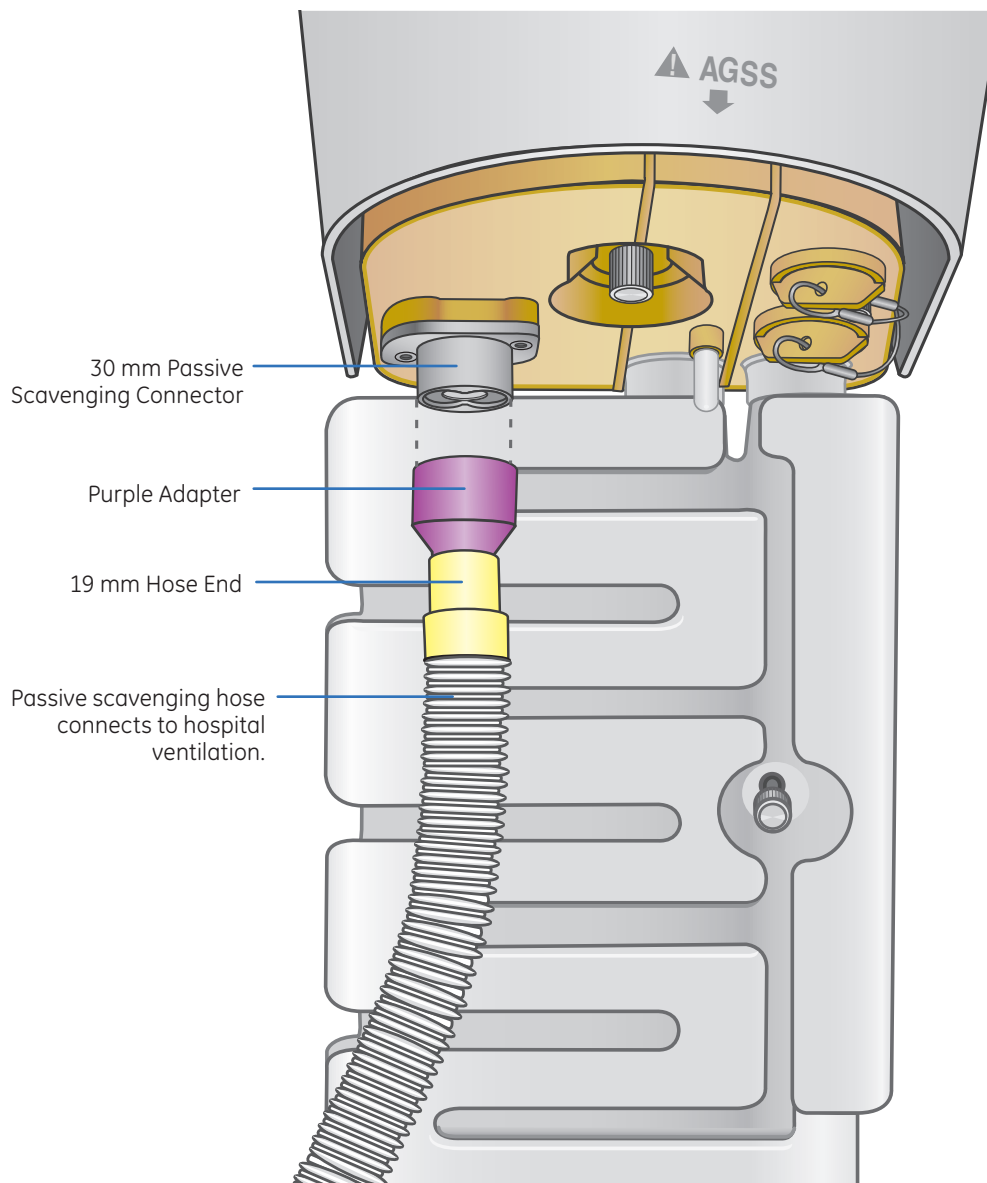

Figure 2.12 Passive Anesthetic Gas Scavenging System

Active Systems

Open Reservoir System

Used with high vacuum (36 L/min) disposal systems. No needle valve or visual indicator bag required. Visual flow indicator present.

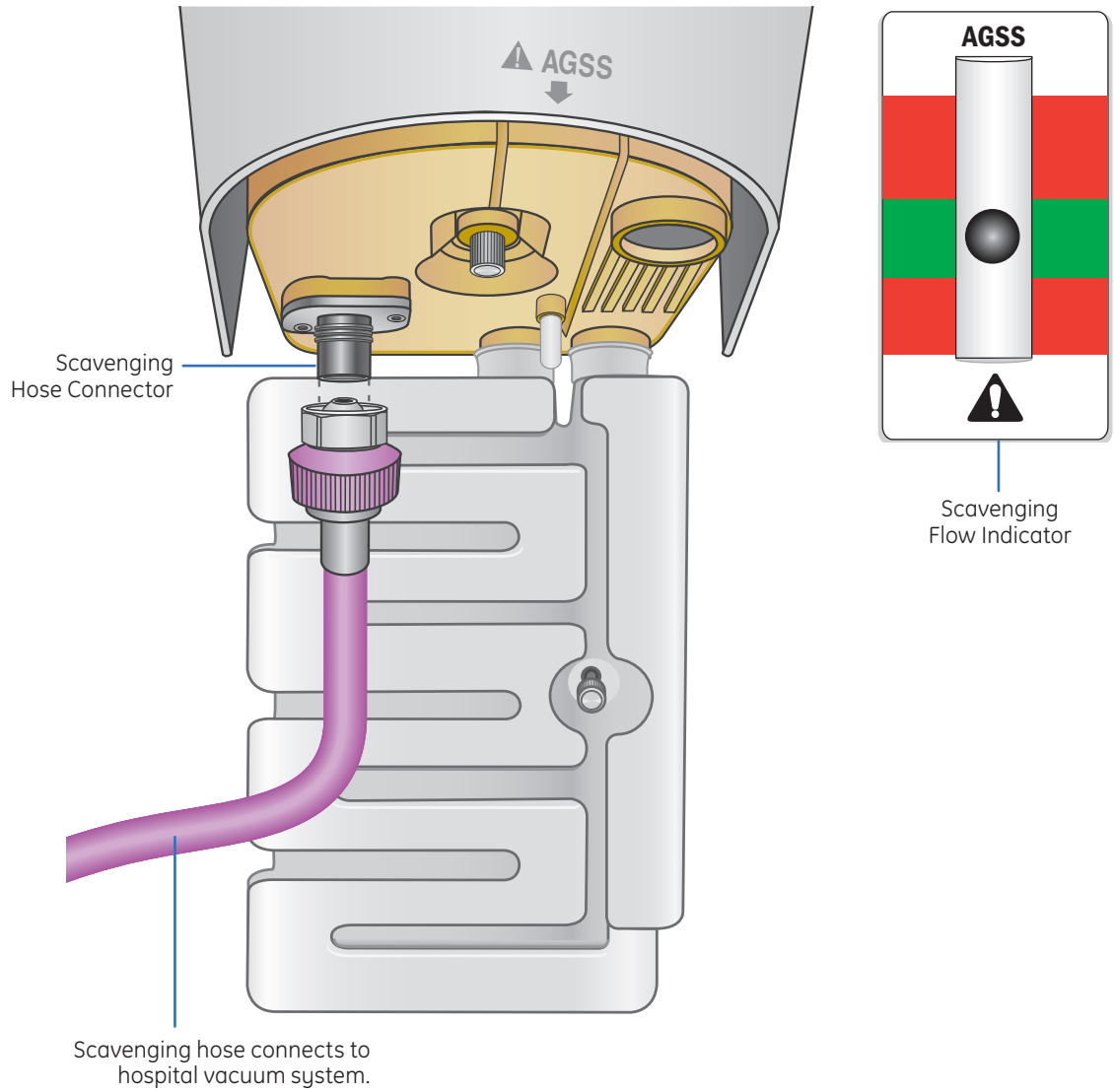

Figure 2.13 Open Reservoir System

Active Adjustable Flow

Provides the capability to adjust the flow with a needle valve and a visual indicator bag which should be properly inflated. To ensure adequate scavenging, adjust the needle valve so the visual indicator bag puffs out slightly with each breath. The bag should not be completely collapsed (close the needle valve slightly) nor completely inflated (open the needle valve slightly).

Problems with Active Adjustable Flow gas scavenging can cause a High Peep alarm. Make sure the scavenge hose is connected to suction. Make sure that the needle valve is open enough that the scavenger bag moves with inspiration and expiration.

You can connect the sample gas exhaust tube to the gas return port. Exhaust gas will be directed to the scavenging system.

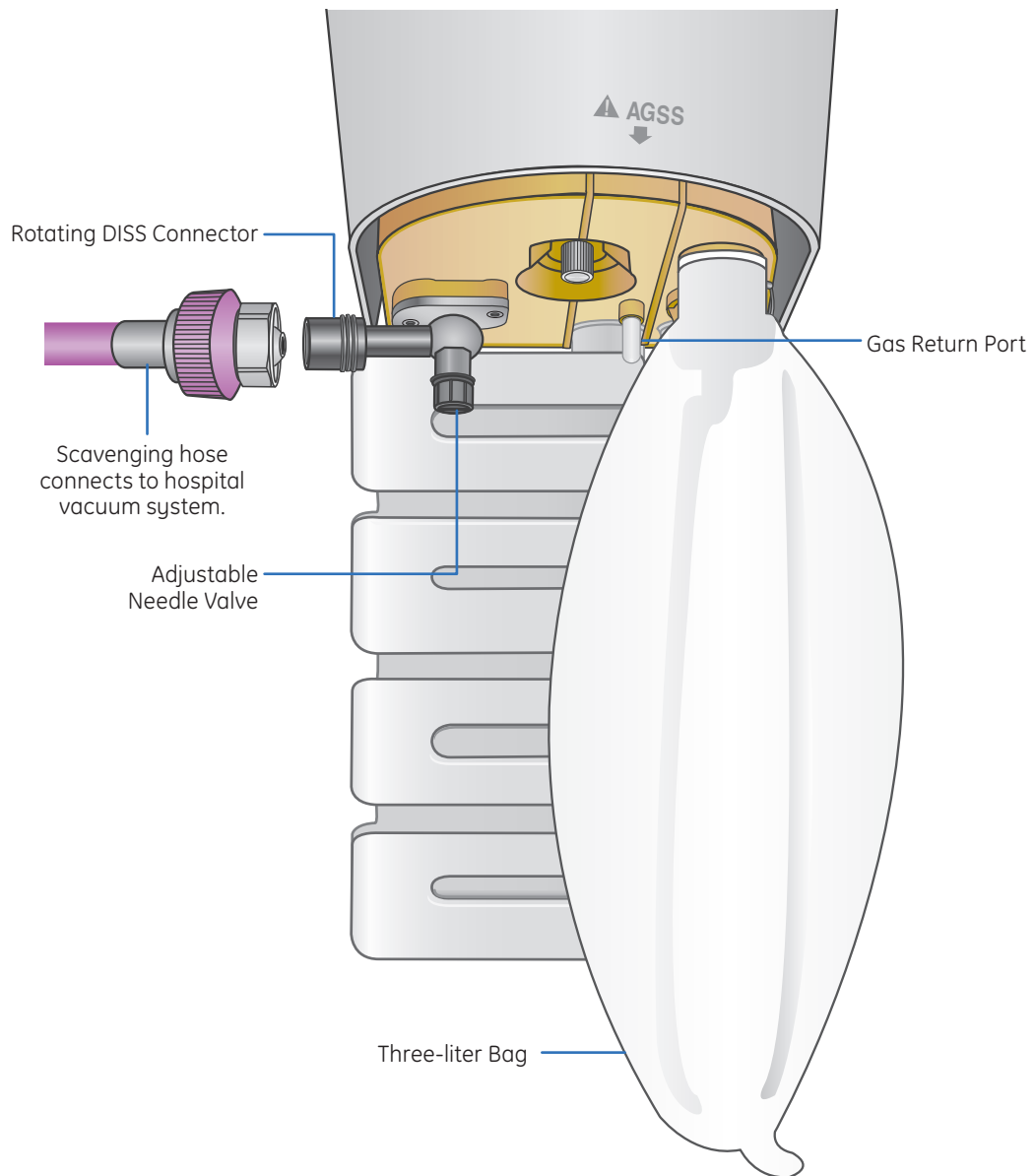

Figure 2.14 Active Adjustable Flow

3 Display Navigation

Using Menus and the ComWheel

Use the menu keys and ComWheel to access and navigate menus, scroll through the quick key settings, make selections, change settings and confirm settings.

1. Push any menu key to access the corresponding menu. In the figure below, the Start Case menu has been accessed by pressing the **Start/End Case** menu key.
2. Turn the ComWheel counterclockwise to highlight the next menu item. Turn the ComWheel clockwise to highlight the previous menu item. In the figure below, **Start Case Now** has been highlighted.
3. Push the ComWheel to make a selection, enter an adjustment window or enter a submenu.
4. Press the **Normal Screen** key to exit the menu and return to the normal monitoring display.



Figure 3.1 Using Menus and the ComWheel



Note! Depending on the menu selected, there may also be a Previous Menu selection or a Normal Screen selection available at the bottom of the menu.

Using Quick Keys

The gas settings and the main ventilator settings for each ventilation mode can easily be changed using the quick keys.

1. Push a Quick Key to select the corresponding setting.
2. Turn the ComWheel to make a change.
3. Push the ComWheel to activate (confirm) the change.
4. A tone sounds and the quick key setting flashes if the ComWheel is not pushed after ten seconds.

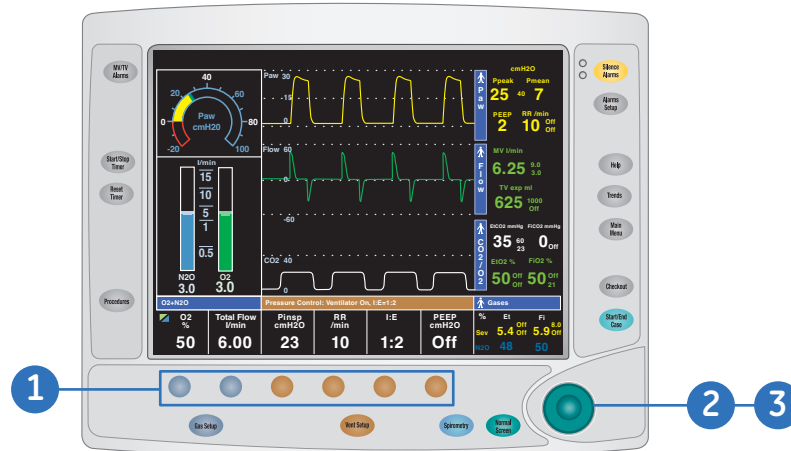

Figure 3.2 Using Quick Keys

The example below details how to change the Inspiratory Pressure using Quick Keys.

1. Press the Quick Key associated with Inspiratory Pressure (located just below the Inspiratory Pressure value displayed on the monitor).
2. Turn the ComWheel to change the setting (turning clockwise increases the level, turning counter-clockwise decreases the level).
3. Press the ComWheel to confirm the new setting.

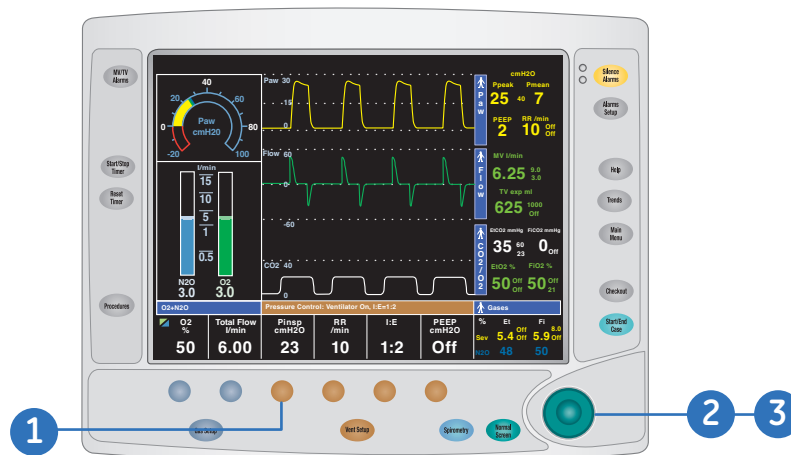

Figure 3.3 Changing Settings



Note! Use the ComWheel to scroll through the quick key setting during a case when no menus are open.

Main Menu

There are many options that are accessed through the Main Menu, including:

- **Trends:** This will be discussed in more detail in the Ventilation section
- **System Status:** Allows you to view battery charge, tank and pipeline pressures during case or standby, vent drive gas, and altitude
- **Cardiac Bypass:** This will be discussed in more detail in the Operation section
- **Fresh Gas Usage:** View the volume of O₂, Air, N₂O and agents used for the three most recent cases.
- **Screen Setup:** Allows you to select waveform options, sweep speed, time and date, and screen brightness. You can also activate a split screen from the Screen Setup menu, such as an airway pressure gauge
- **Parameters Setup:** Setup of Spirometry, O₂, CO₂, and agent
- **Calibration:** Only accessible when the Avance is in Standby
- **Super User:** A password protected area where system configuration can be changed
- **Normal Screen:** Back to normal view of the display

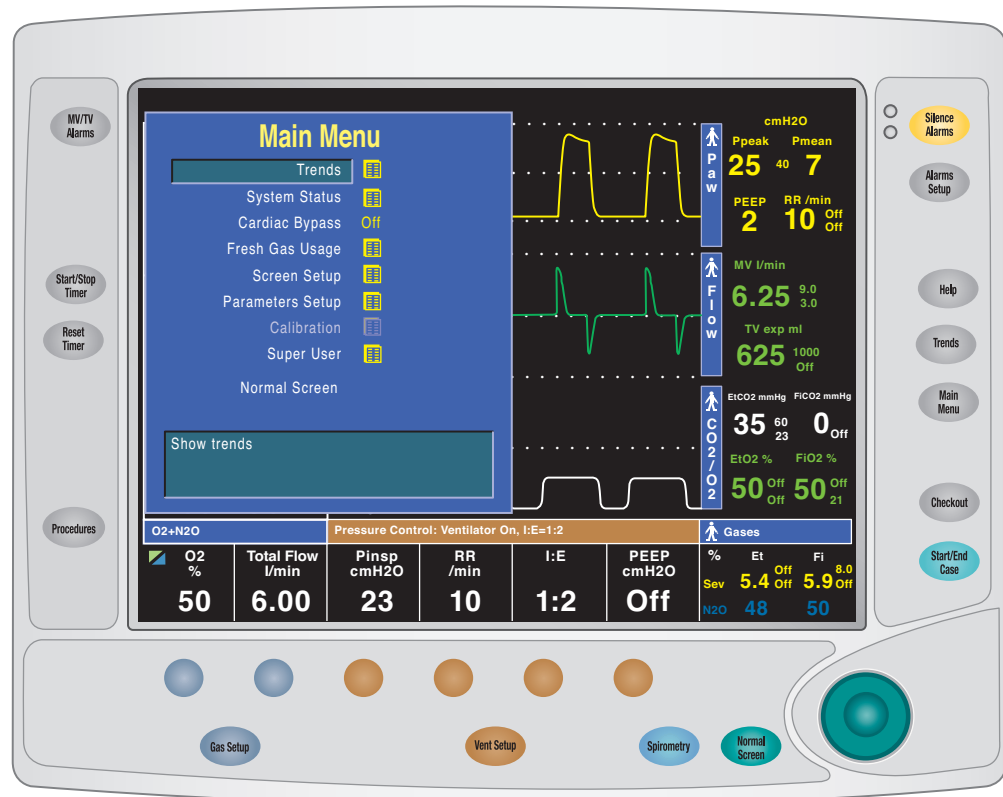

Figure 3.4 Main Menu

Select Page

Use the **Select Page** menu to switch the normal screen view. A default screen view (case type) and four preset normal screen views are available.

1. From the normal screen with no menus showing, press the ComWheel.
2. An arrow to the right of the menu item indicates the page view that is in use.
3. A corresponding message shows in the general message area.

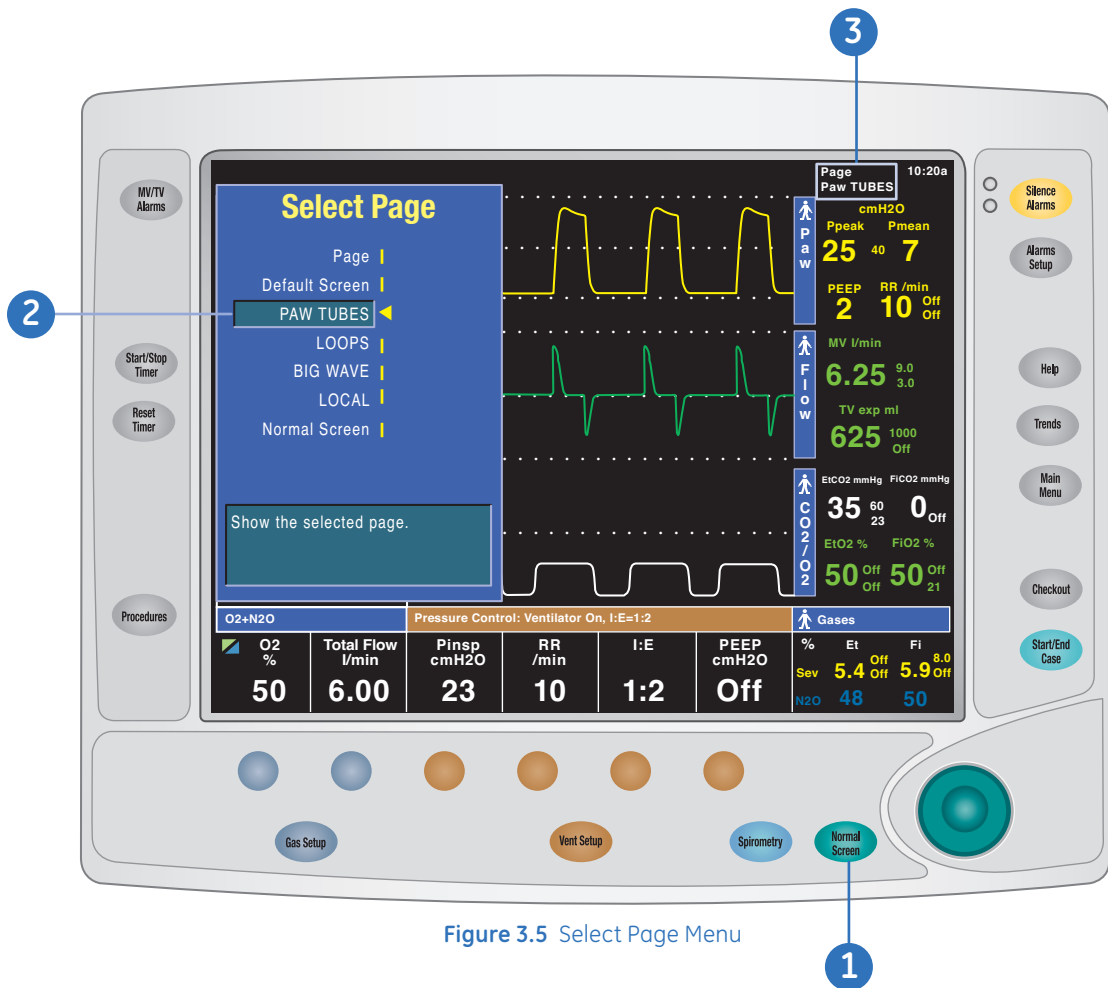

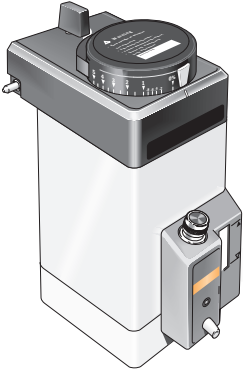

Figure 3.5 Select Page Menu

Select a view or select **Normal Screen** to leave the selections unchanged. If no arrow shows on the Select Page menu, a customized normal screen view is in use.

4 Vaporization

Types, Mounting & Filling

The Avance can be configured to hold up to two vaporizers in line. An additional vaporizer can be mounted for storage purposes only. Any of the Tec (temperature compensated) vaporizers can be utilized. We will discuss the Tec 5, 6, 6 Plus and Tec 7 vaporizers. The Tec 7 includes a new filling mechanism allowing you to rapidly fill the vaporizer while minimizing any spill or airlocks you may have incurred in the past with the key fill type vaporizers.

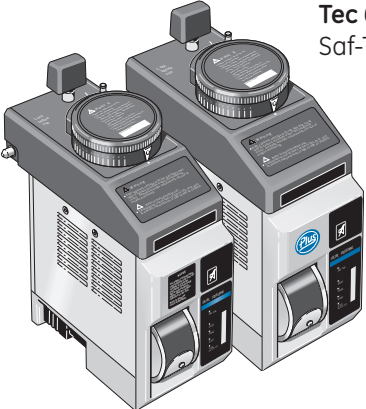
Tec Series Model and Filling Options:	Anesthetic Agent Options:
 <p>Tec 5 Funnel fill or key fill</p>  <p>Tec 7 Funnel fill or Easy-fill™</p>	<div data-bbox="1016 657 1455 848" style="background-color: red; color: white; padding: 10px; text-align: center;"> <p>Halothane Red</p> </div> <div data-bbox="1016 884 1455 1075" style="background-color: purple; color: white; padding: 10px; text-align: center;"> <p>Isoflurane Purple</p> </div> <div data-bbox="1016 1110 1455 1302" style="background-color: blue; color: white; padding: 10px; text-align: center;"> <p>Enflurane Orange</p> </div> <div data-bbox="1016 1337 1455 1528" style="background-color: yellow; color: white; padding: 10px; text-align: center;"> <p>Sevoflurane Yellow</p> </div>
 <p>Tec 6 and 6 Plus Saf-T-fill</p>	<div data-bbox="1016 1570 1455 1761" style="background-color: blue; color: white; padding: 10px; text-align: center;"> <p>Desflurane Blue</p> </div>

Selectatec Interlock Mounting System

The Vaporization System uses the Selectatec Interlocking Mounting system, which locks out vaporizers not in use, by directing gas flow past those vaporizers not being used.

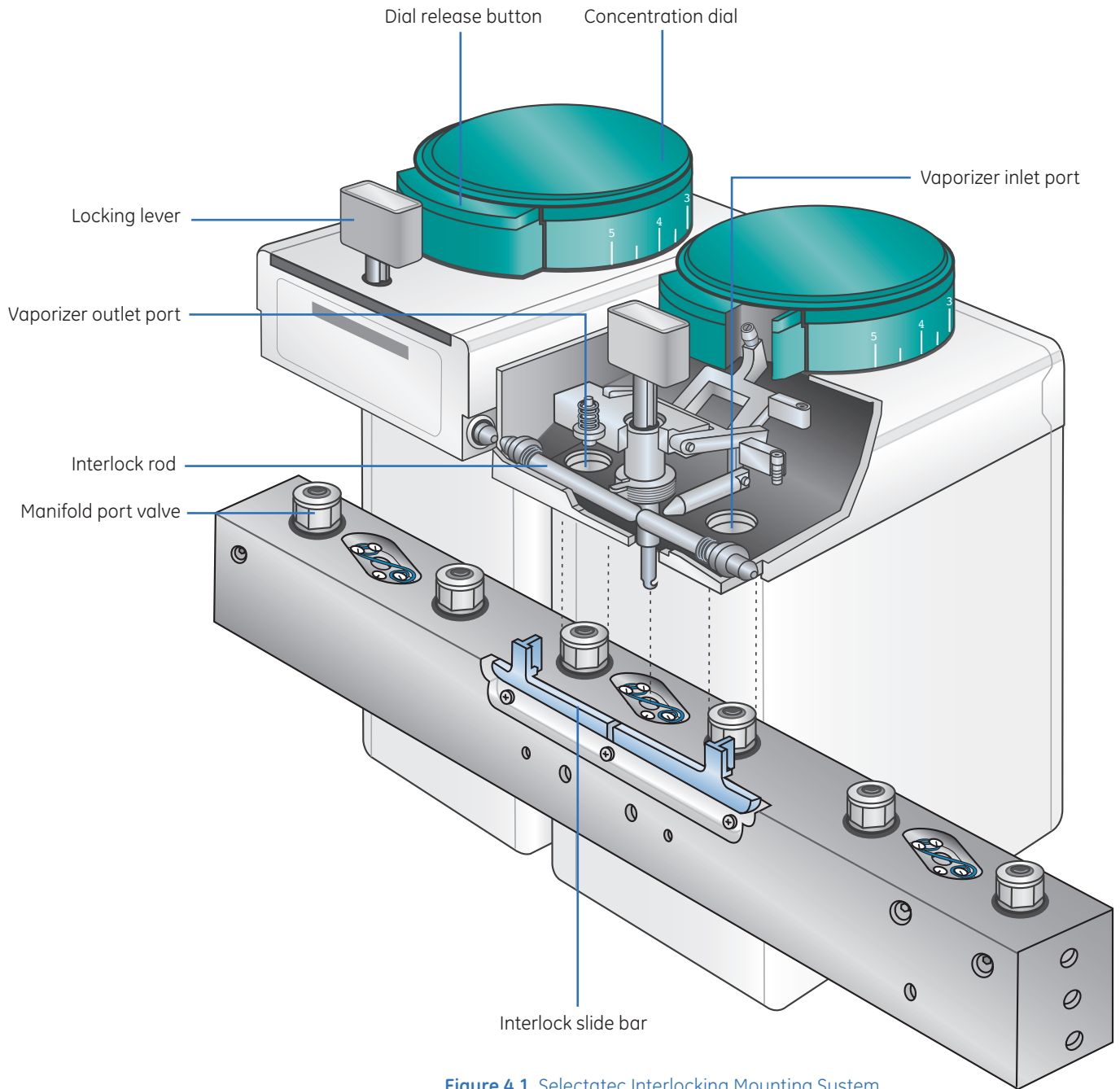

Figure 4.1 Selectatec Interlocking Mounting System

Tec 5 Filling

To Fill the Tec 5 Vaporizer

1. Attach the appropriate (color-coded and indexed) key filler to the agent bottle.
2. Insert the key filler into the vaporizer and lock into place by lowering the vaporizer locking lever.
3. Raise the agent bottle.
4. Release the fill lever on the front of the vaporizer.

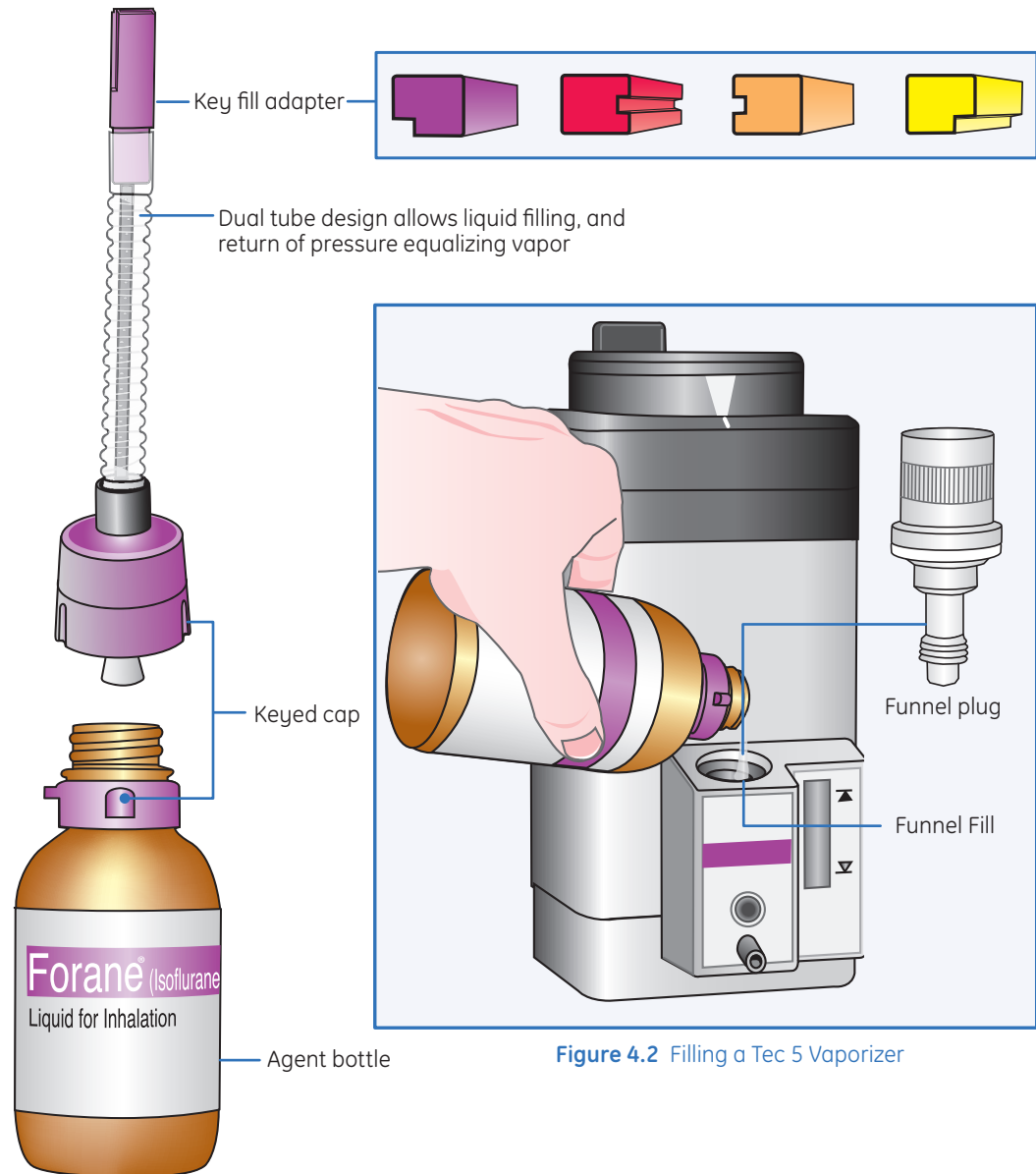

Figure 4.2 Filling a Tec 5 Vaporizer

After Filling the Tec 5 Vaporizer

1. Close the fill lever.
2. Lower the bottle.
3. Unlock and remove the key filler.
4. Remove the key filler for the bottle and recap.

Tec 6 & 6 Plus:

Tec 6 & 6 Plus Vaporizer: For Desflurane (Suprane).

Alarm Mute: Button silences the vaporizer alarm.

Operational LED: Lighted when the vaporizer is plugged into an electrical supply and the agent has warmed to operation temperature. The vaporizer cannot be used until this LED is lighted.

No Output LED: Lights when there is no agent or during a malfunction of the vaporizer.

Low Agent LED: Lights when the agent is too low for reliable output.

Warm-Up LED: Lights during power-up and locks out the vaporizer until the operational temperature is reached.

Alarm Battery Low LED: Lights when the vaporizer alarm battery (9 volt) needs to be changed.

Fill Indicator: LCD that displays the fill level. There are icons for Low and Full as well as an arrow icon that indicates at what level the vaporizer will accept a full bottle of Desflurane.

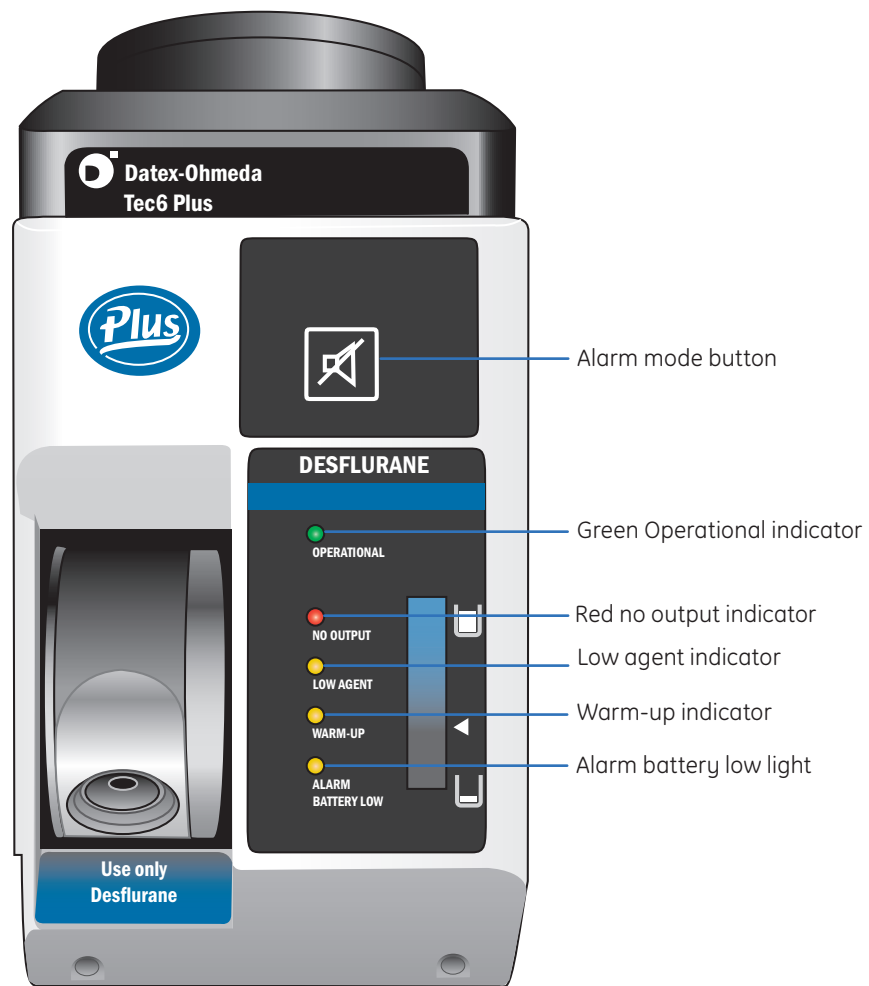

Figure 4.3 Tec 6 & 6 Plus Vaporizer

Tec 6 & 6 Plus Filling

Filling the Tec 6 vaporizer

1. Uncap the Desflurane bottle and insert into the vaporizer fill port (twisting and turning while inserting the bottle may prevent the o-rings from damage or misalignment).
2. Raise the bottle to fill the Tec 6 vaporizer. The bottle should raise easily, if not, the bottle is not inserted far enough.

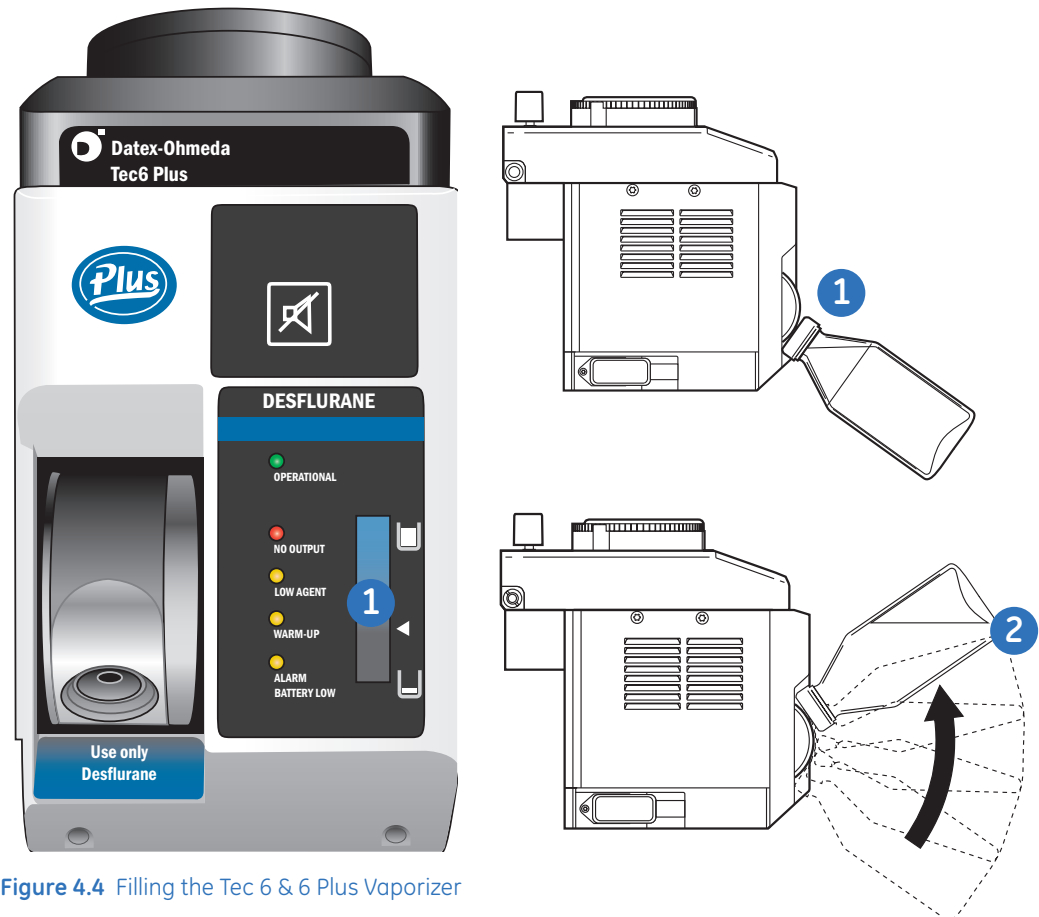

Figure 4.4 Filling the Tec 6 & 6 Plus Vaporizer

After Filling the Tec 6 vaporizer

1. Lower the Desflurane bottle and remove as described above for insertion.
2. Recap the Desflurane bottle.

Tec 7 and Easy-Fil™ Adapters

The Tec 7 vaporizer utilizes an Easy-fil Adapter system. Easy-fil Adapters are easy to use, color coded and key indexed. This system replaces the Key filler system.

Filling the Tec 7 vaporizer

1. Uncap the agent bottle and attach the Easy-fil adapter.
2. Unscrew the fill connection cap from the vaporizer.
3. Invert the bottle and insert the Easy-fil adapter into the vaporizer. It may be necessary to turn the bottle until it drops to its lowest position.
4. Press and hold the bottle down until the vaporizer is filled. Air bubbles in the bottle will indicate that agent is flowing into the vaporizer.

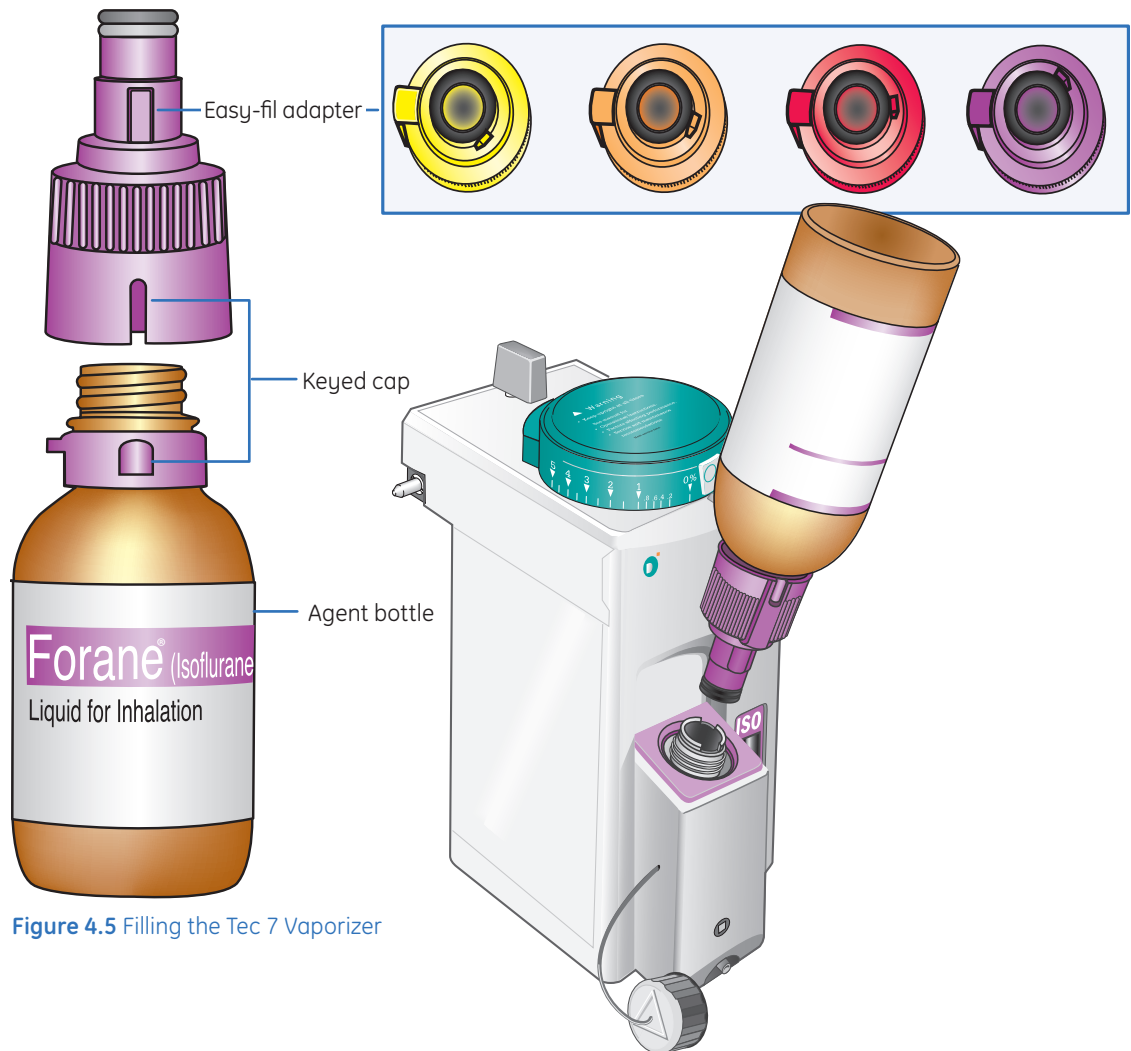

Figure 4.5 Filling the Tec 7 Vaporizer

After Filling the Tec 7 vaporizer

1. Remove the bottle from the vaporizer and remove the Easy-fil Adapter.
2. Recap the agent bottle and the vaporizer.

5 Advanced Breathing System

The Avance includes the Advanced Breathing System (ABS). The ABS is a small compact system with a 2.7L circuit vent volume designed for low flow anesthesia. It also allows for rapid control of fresh gas flows and concentrations. Changes to fresh gas concentration are applied at the next breath, which allows for the quick administration and removal of agent from the system.

Fresh gases are delivered just behind the inspiratory check valve and then immediately delivered into the inspiratory limb of the breathing circuit. Any changes to fresh gas concentration or flows are immediately delivered to the patient, which gives you rapid control of fresh gas flows and concentrations at the point where it matters, the patient. In addition, the ABS is autoclavable, allowing you to rapidly disassemble it, autoclave it, and reassemble the breathing system because it does not retain heat. You can assemble it quickly and return it to service -ready for the next case.

The ABS is entirely latex free. There are no cables and hoses, which minimizes improper connections or disconnects, and can integrate either passive or active scavenging systems.

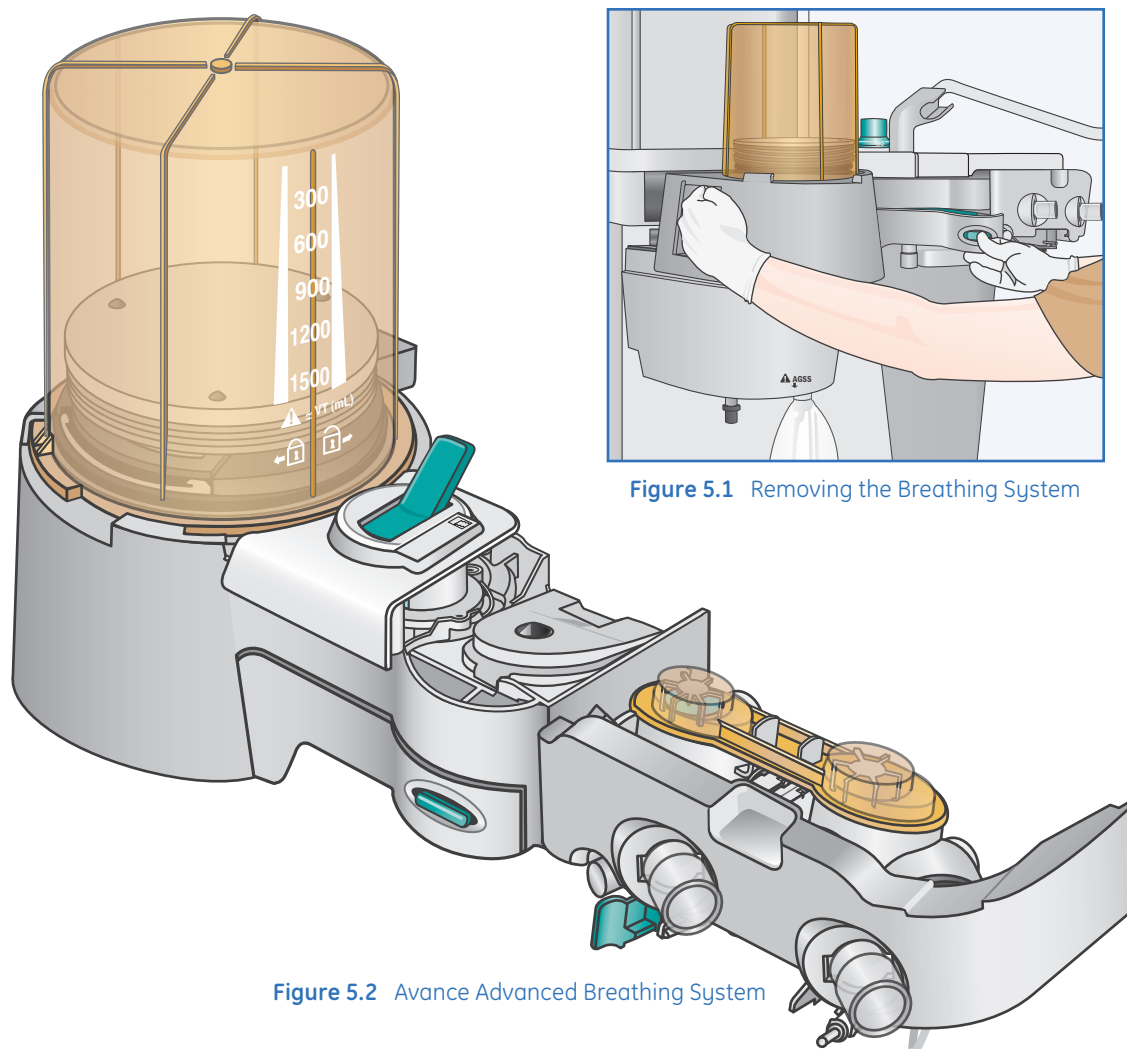

Figure 5.1 Removing the Breathing System

Figure 5.2 Avance Advanced Breathing System

Bag/Vent Switch

The Bag/Vent Switch is a bi-stable mechanical switch that selects between manual ventilation (bag) and mechanical ventilation (vent). When the switch is changed from bag to vent mode, the ventilator is automatically switched on.

Be sure to check the ventilator parameters before changing from bag to vent mode. Also keep in mind that the APL Valve is not in the circuit while the ventilator mode is active.

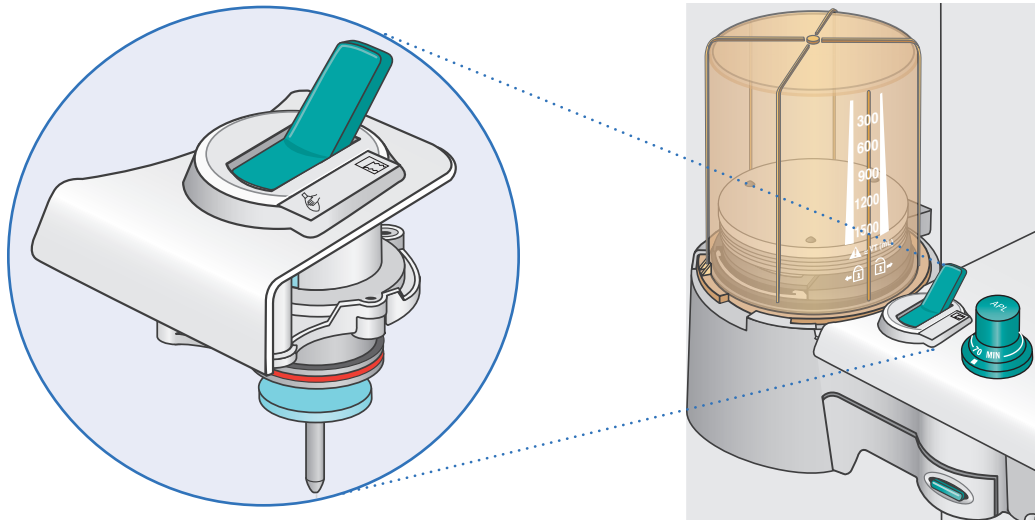

Figure 5.3 Bag/Vent Switch

APL Valve

The APL Valve allows you to change the settings from minimum to **70 cmH₂O**. When the APL is between **30** and **70 cmH₂O**, you will notice that the valve becomes a tactile indicator, meaning that the knob clicks at each additional cmH₂O.



Note! The APL can go from 70 cmH₂O to minimum with one turn.

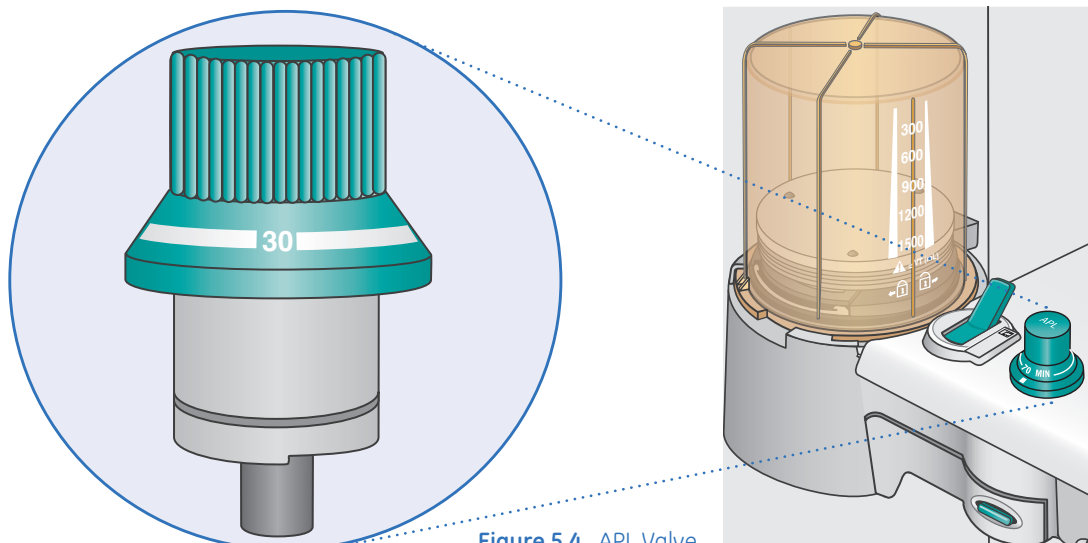

Figure 5.4 APL Valve

Bag Support Arm

The ABS also provides for the use of a Bag Support Arm. This bag arm is different than traditional anesthesia systems because it does not actually carry patient gas. Patient gas is carried through the bag arm hose from the ABS out to the bag. The bag can be used while attached to or detached from the bag support arm.

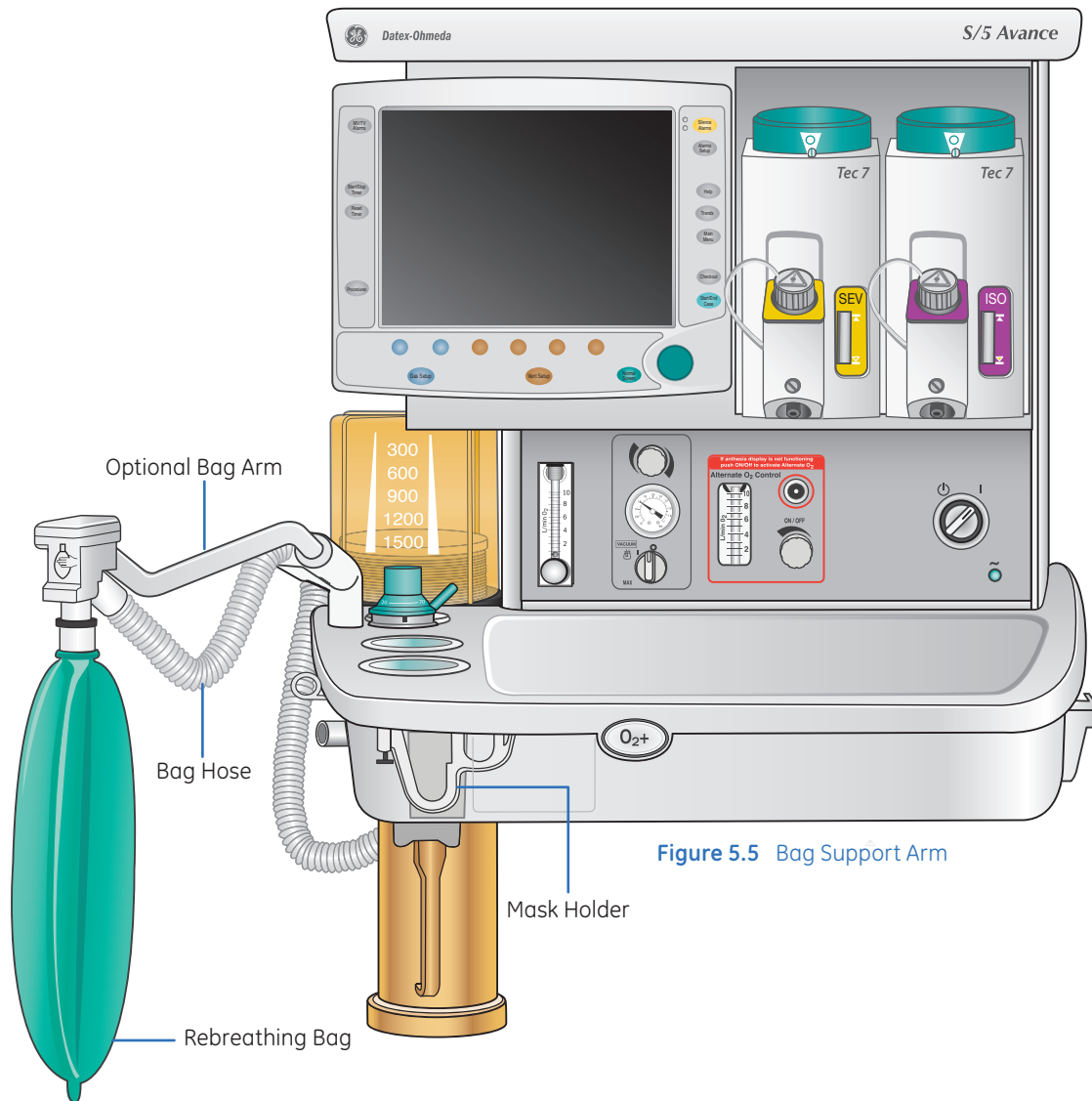

Figure 5.5 Bag Support Arm

Absorber Canister

The canisters hold 950 ml and are available as disposable or reusable. The reusable canister is autoclavable. The Advanced Breathing System also includes an EZChange mode for the canister. The EZChange canister mode seals the breathing circuit when the canister holder is down. While the absorber canister is out of the breathing circuit, the patient re-breaths exhaled gases without any gas passing through the absorbent. When the canister holder is down, the message **CO₂ Absorber Out of Circuit** shows in the waveform area on the anesthesia display. Systems with EZChange canister mode have a label on the canister holder. Both disposable and reusable canisters can be used with the EZChange option.

These canisters can be exchanged simply by pushing on the teal-colored release latch and disconnecting the canister, removing it for replacement.

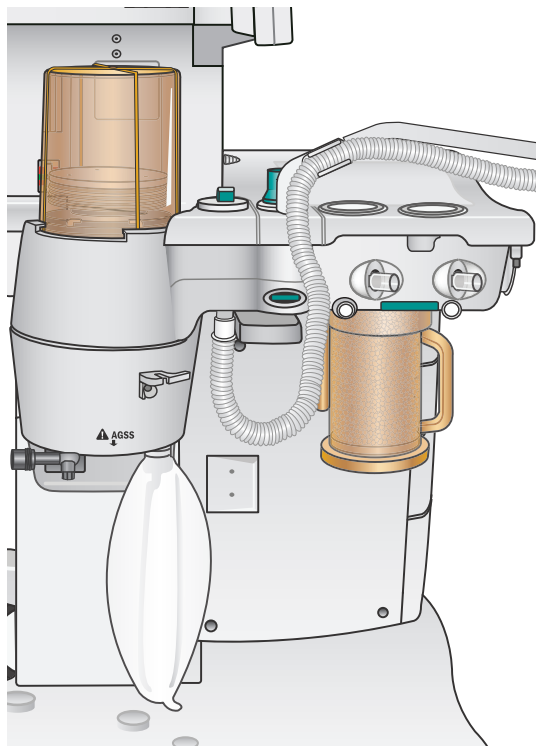

Figure 5.6
Canister on Standard Machine

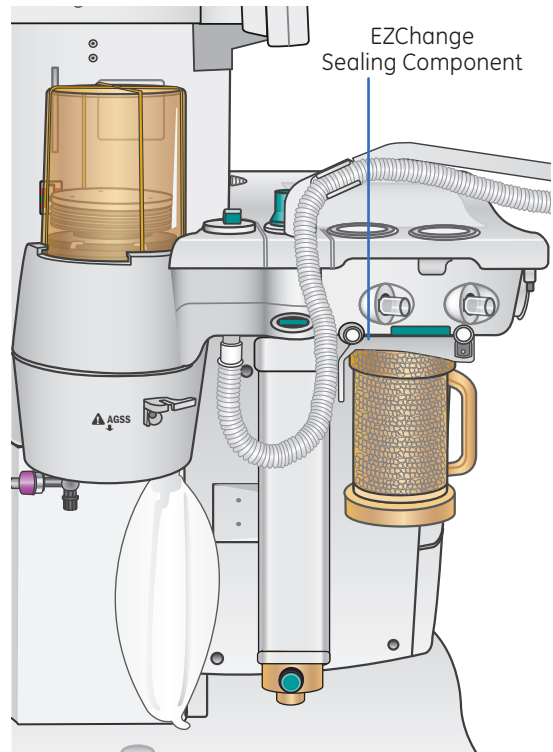

Figure 5.7
Canister on Machine with EZChange Mode

Canister Access on a Standard Machine

To remove a canister on a standard system:

1. Hold the canister by the handle.
2. Push the Absorber Canister Release.
3. Push it down and away from the attachment point/support pins to remove the canister.

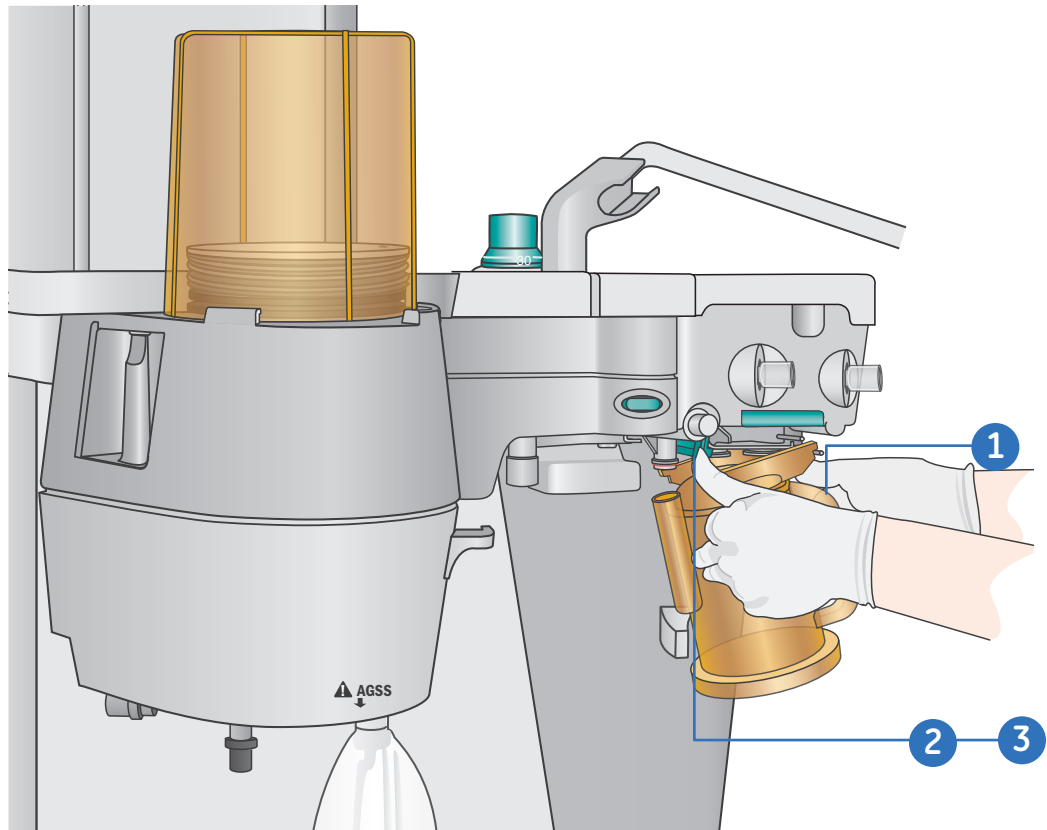

Figure 5.8 Removing the Canister

To replace a canister on a standard system:

1. Hold the canister by the handle.
2. Tilt the canister down and place the lip of the canister so that it catches at its attachment point/support pins.
3. Push the other side of the canister up until you hear it snap into place.



Note! For standard systems (systems without the EZChange Mode), the breathing system is open to air and you will have a leak when the canister is out of the cradle.

Canister Access on a Machine with the EZChange Mode

To remove a canister on a system with the EZChange Mode:

1. Hold the canister by the handle.
2. Push the Absorber Canister Release to unlock the canister cradle.
3. Tilt the cradle down, and slide the canister up and out of the cradle.

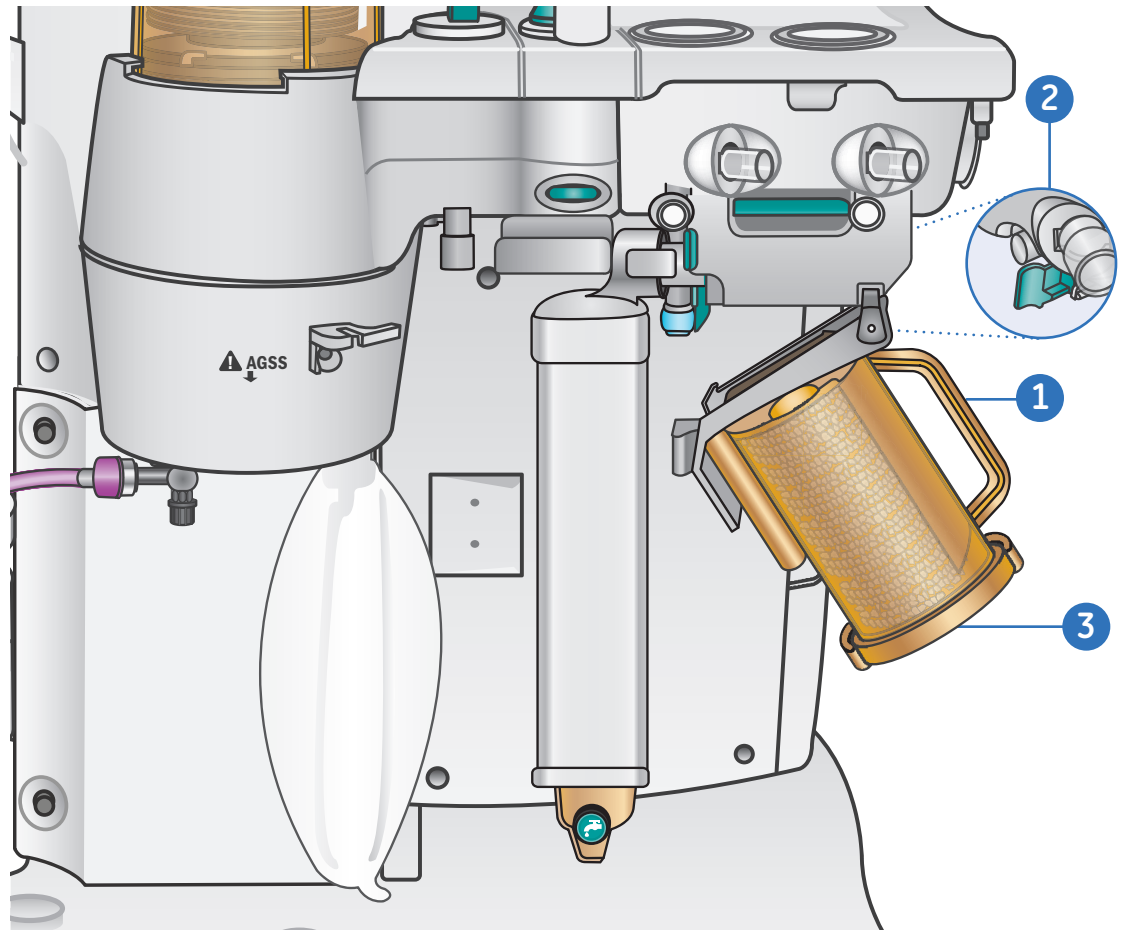

Figure 5.9 Canister on Machine with EZChange Mode

To replace a canister on a system with the EZChange Mode:

1. Hold the canister by the handle.
2. Slide the canister into the cradle.
3. Tilt the cradle up to lock into place.

Condenser

Use the optional condenser to remove water in the system that is produced from the reaction of CO₂ gas with the absorbent. The condenser is connected between the outlet of the absorber canister and the inlet of the circuit module. Moisture in the gas is condensed into water droplets, which run into the condenser's reservoir. The condenser adds 715 ml of volume to the breathing system.



Note! Visually check the condenser reservoir daily, and drain if needed.

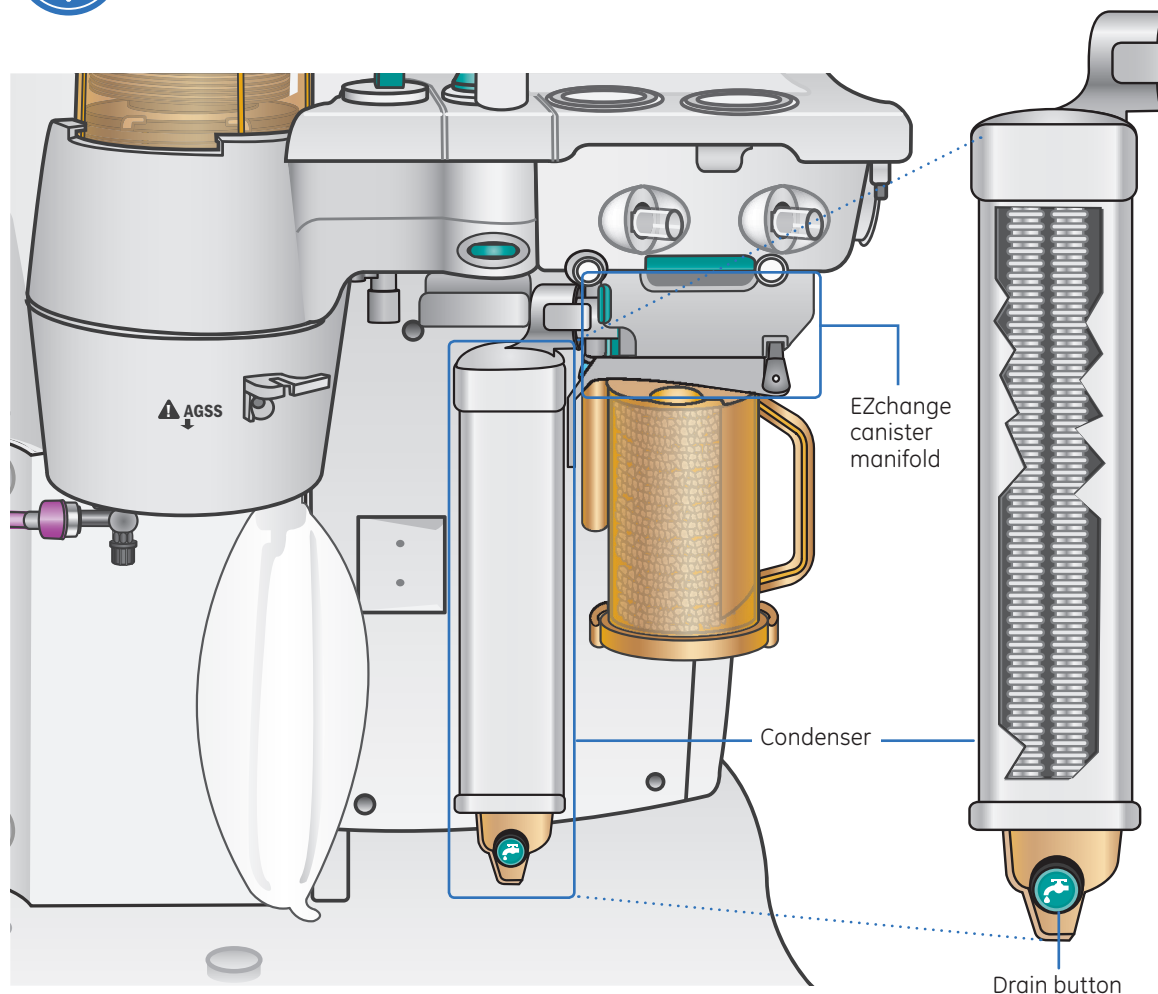

Figure 5.10 Optional Condenser

Flow Sensors

Flow Sensors are differential pressure pneumotachs that measure inspiratory pressures and both inspiratory and expiratory volumes.

The Flow Sensors are either plastic or metal. The plastic Flow Sensors may be sterilized using only liquid or gas methods. The metal Flow Sensors may be sterilized using liquid, gas or steam autoclave methods.

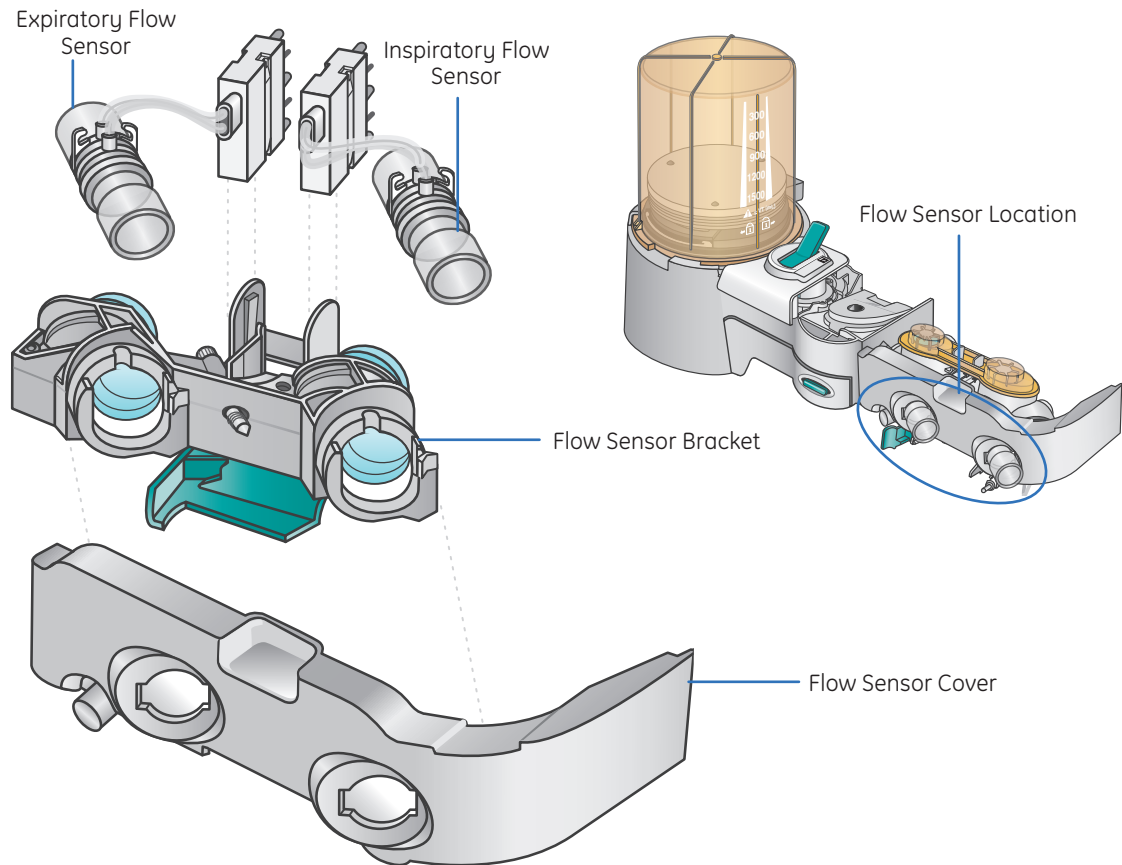

Figure 5.11 Flow Sensors

The flow sensors should be calibrated daily by removing them from the system. On-screen instructions are available through **Main Menu > Calibration > Flow and Pressure**.

1. Set the Bag/Vent switch to Bag.
2. Remove the flow sensor module.
3. Wait for **No insp flow sensor** and **No exp flow sensor** alarms to occur.
4. Reinsert the flow sensor module. Make sure the flow sensors are securely latched when they are reinserted. Wait for alarms to clear.
5. Start mechanical ventilation when ready.



Note! Room temperature fluctuations of more than 5°C may affect sensor measurements. Recalibrate the flow sensors if the room temperature changes by more than 5°C.

Preventing Moisture Buildup

Pooled water in the flow sensors or water in the sensing lines may cause false alarms. Small beads of water or a foggy appearance in the flow sensors is okay.

Water results from exhaled gas and the chemical reaction between CO_2 and the absorbent that takes place within the absorber canister.

At lower fresh gas flows more water builds up because less gas is scavenged and more CO_2 stays in the absorber to react and produce water. Also, more moist and exhaled gas stays in the patient circuit and the absorber.

To help prevent moisture buildup:

- Equip systems with the optional condenser
- Empty the water reservoir in the canister when changing the absorbent
- Ensure that water condensing in the breathing circuit tubes is kept lower than the flow sensors and is not allowed to drain back into the flow sensors
- Water condensation in the breathing circuit tubing might be lessened by using a Heat and Moisture Exchange (HME) filter at the airway connection

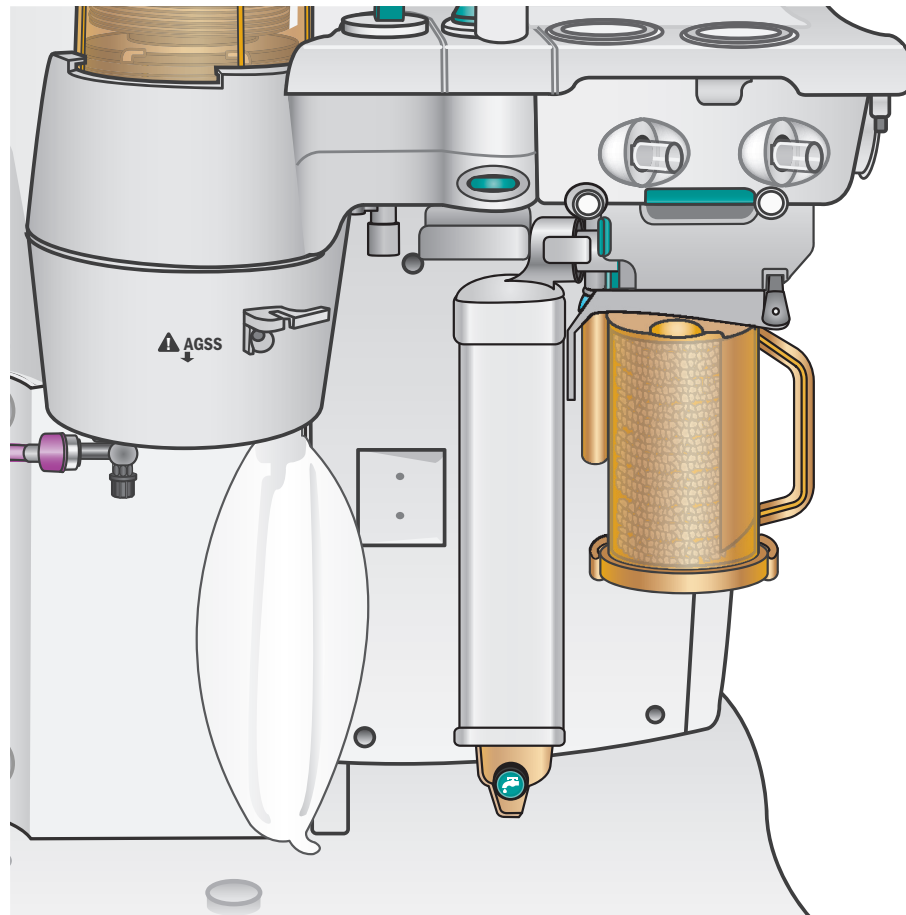

Figure 5.12 Optional Condenser and Canister

Auxiliary Common Gas Outlet (ACGO)

The optional Auxiliary Common Gas Outlet (ACGO) is not required for operation of the Avance. A negative pressure leak test can be accomplished through the ACGO.

Set the switch to ACGO position to have fresh gas flow through the ACGO port. The ACGO may be used to provide fresh gas to an auxiliary manual breathing circuit, such as a Mapleson or Jackson-Reese circuit.



Note! Mechanical ventilation is not available when operating an auxiliary manual breathing circuit with fresh gas from the ACGO. Volume and pressure monitoring are also not available.

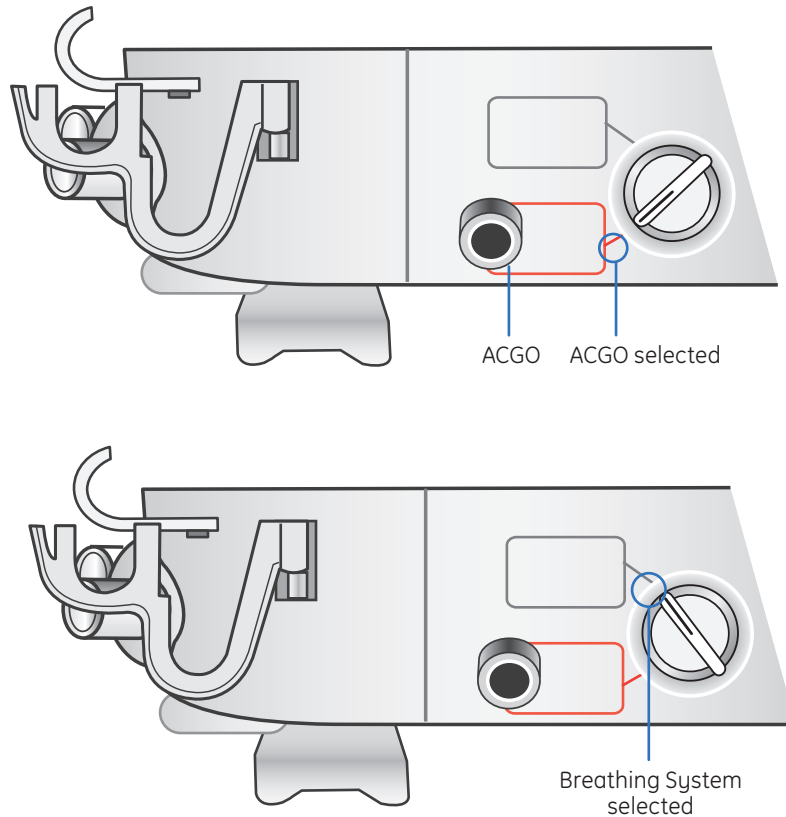

Figure 5.13 ACGO

6 Operation

The Start Case Menu

Access the Start Case menu by pushing the **Start/End Case** key or by selecting **Start Case** from the Checkout menu. Use the Start Case menu to set the case data and to start the gas flow.

You can also use the **Start/End Case** key to end the case, stop gas flow and end the patient alarms when the case has completed. Set the Bag/Vent switch to Bag, push the **Start/End Case** key and select **End Case Now**.



Figure 6.1 Start Case Menu



Note! *Start of Case: The starting O₂ concentration and total flow can be configured to the hospital's specifications.*

Start Case Settings

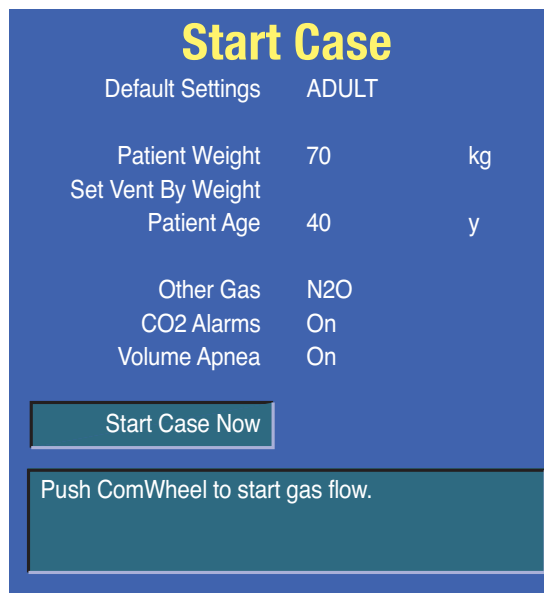

Figure 6.2 Start Case Menu

Default Settings: Start a case using the default settings by case type defined by the Super User. Default Settings contains five case type selections. Each case type has pre-set values for Patient Weight, Patient Age, Other Gas, and Volume apnea. The first four of the default case types are configured and named by the Super User. The fifth default case is Last Case.

Patient Weight: Enter patient weight here. The default value for Patient Weight is configured in the Super User menu.

Set Vent by Weight: The Set Vent By Weight menu item is accessible when the ventilation mode is set to VCV or PCV-VG. Use this setting for breath rate and tidal volume calculations based on the set patient weight. The Default Settings selection shows **Weight** when **Set Vent By Weight** is selected.

Patient Age: Enter patient age here. The default value for Patient Age is configured in the Super User menu.

Other Gas: Select a balance gas (N₂O or Air) to use with O₂. The default value for Other Gas is configured in the Super User menu.

CO₂ Alarms: Set CO₂ Alarms to **Off** during manual ventilation to disable the CO₂ alarms. The **CO₂ Alarms Off** message shows in the general message field. The CO₂ alarms limits waveforms numerics show as dashes during a case. If CO₂ Alarms is set to **Off**, the alarms remain disabled until the Bag/Vent switch is set to ventilator, the case is ended, or the CO₂ Alarms is set to **On**.

Volume Apnea: Volume Apnea is not shown on the Start Case menu when disabled by the Super User. Set Volume Apnea to **Off** to disable the volume apnea alarm during manual ventilation. **Volume Apnea Off** shows in the general message field. The volume apnea alarm remains disabled until the Bag/Vent switch is set to ventilator or Volume Apnea is set to **On**.



Note! When Volume Apnea is set to **Off** during manual ventilation and then mechanical ventilation is started, the volume apnea alarms are active. **Volume Apnea - Off** requires confirmation through a pop-up window when manual ventilation is resumed.

Start Case Now: Starts gas flow and removes the Start Case menu from the display.

Start a Case With Default Settings

1. Press any two Quick Keys in succession.
2. Press the **Start/End Case** key.
3. Press **Normal Screen**.



Figure 6.3 Start Case with Defaults

Minimum Alveolar Concentration (MAC)

The adjusted Minimum Alveolar Concentration (MAC) is calculated based on the patient age entered in the Start Case menu. The default patient age of selected case type is used if no patient age is entered.

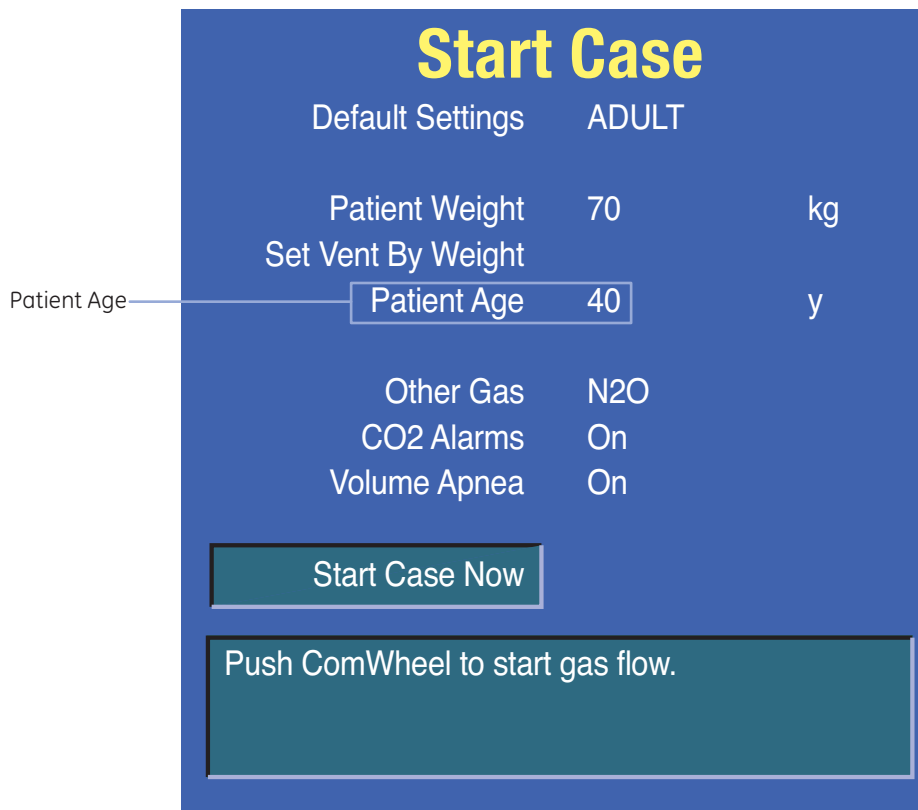

Figure 6.4 Start Case Menu

The MAC value is calculated from the exhaled gas concentration and the related affects based on the age of the patient. Typically, younger patients have better liver function and can clear a drug faster, resulting in a higher MAC value. The MAC calculation used is based on the Eger formula. When two agents are detected, the MAC values of each agent are added together. The MAC value range is **0.0** to **9.9**.

The adjusted MAC value shows on several areas of the screen including in the mini-trend, agent waveform numeric information, gases digit field, and graphical trends page. MAC data shows as dashes if there is not an airway module installed in the module bay.

Ventilator Menus

Ventilator Modes and Settings

Push the **Vent Setup** key to display the corresponding menu. Use the ComWheel to navigate through the menu.

Using the Vent Setup Menu:

1. Push the **Vent Setup** key.
 - An arrow to the right of the mode indicates the current mode
 - Adjust Settings is selected by default
2. Push the ComWheel to enter the adjustment window for the selected mode.
3. Use the ComWheel to navigate through the adjustment window and to change a value.
4. Scroll up to **Confirm** and push the ComWheel to confirm a change.
5. Push the **Normal Screen** key or select **Exit**.



Figure 6.5 Vent Setup

Adjust Settings: Adjust settings of the current ventilation mode. Available settings on the secondary menu are specific to the vent mode. Some settings can also be adjusted using the Quick Keys.

Mode: Select/change the vent mode. Additional safety feature requires you to select **confirm** once you have changed modes.

Spirometry: Change loop type, scaling, switch between **adult** and **pediatric**, choose data from d-lite sensor (E-Gas or M-Gas) or flow sensors (ventilator), view reference loops, and save and erase loops. Spirometry is discussed in more detail in the Spirometry section.

Note!
To preset ventilator and alarm settings, select the **Start/End Case** key, followed by the **Vent Setup** or **Alarm Setup** key.

Gas Setup

Push the **Gas Setup** key to display the corresponding menu. Use the ComWheel to navigate through the menu.

Using the Gas Setup Menu:

1. Push the **Gas Setup** key.
2. Push the ComWheel to enter the adjustment window for the selected setting.
3. Use the ComWheel to navigate through the adjustment window and to change a value.
4. Push the ComWheel to confirm a change.
5. Push the **Normal Screen** key or select **Exit**.

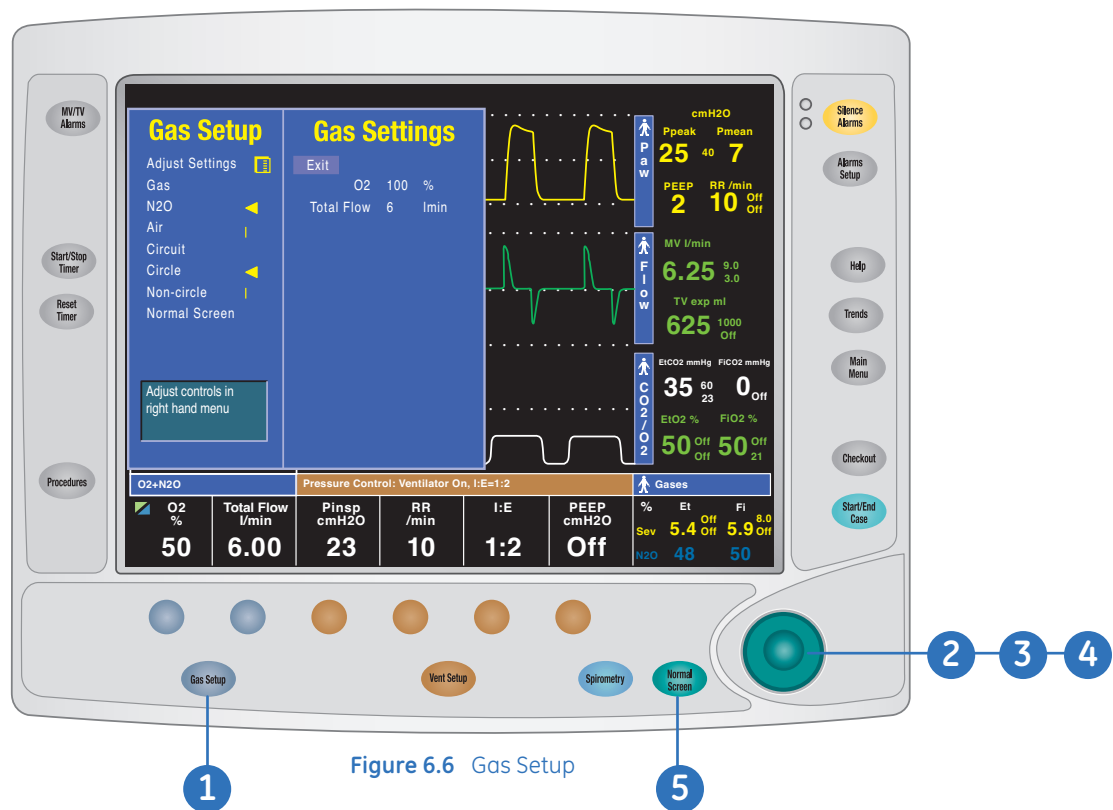

Figure 6.6 Gas Setup

Gas Setup Settings:

Adjust Settings: Change O₂, total flow, and agent percentage. These can also be adjusted using the Quick Keys.

Gas: Choose between **nitrous** and **air** for your secondary gas.

Circuit: Choose between **Circle** (the default), or **Non-circle** circuit types.



Note! Use the non-circle circuit mode to divert fresh gas around the inspiratory check valve and out through the inspiratory port. This fresh gas source may be used with circuits that do not have CO₂ absorbent capability (for example, Mapleson variants). Mechanical ventilation and tidal volume monitoring are not available when using the non-circle circuit.

Trends

1. Push the **Trends** key.
2. Select the desired view. An arrow indicates the current trend view.
3. Select **Cursor** to scroll through the current trend view.
4. Push the ComWheel to return the highlight to **Cursor**.
5. Select **Next Page** to view additional parameters.
6. Push the **Normal Screen** key or select **Previous Menu**.

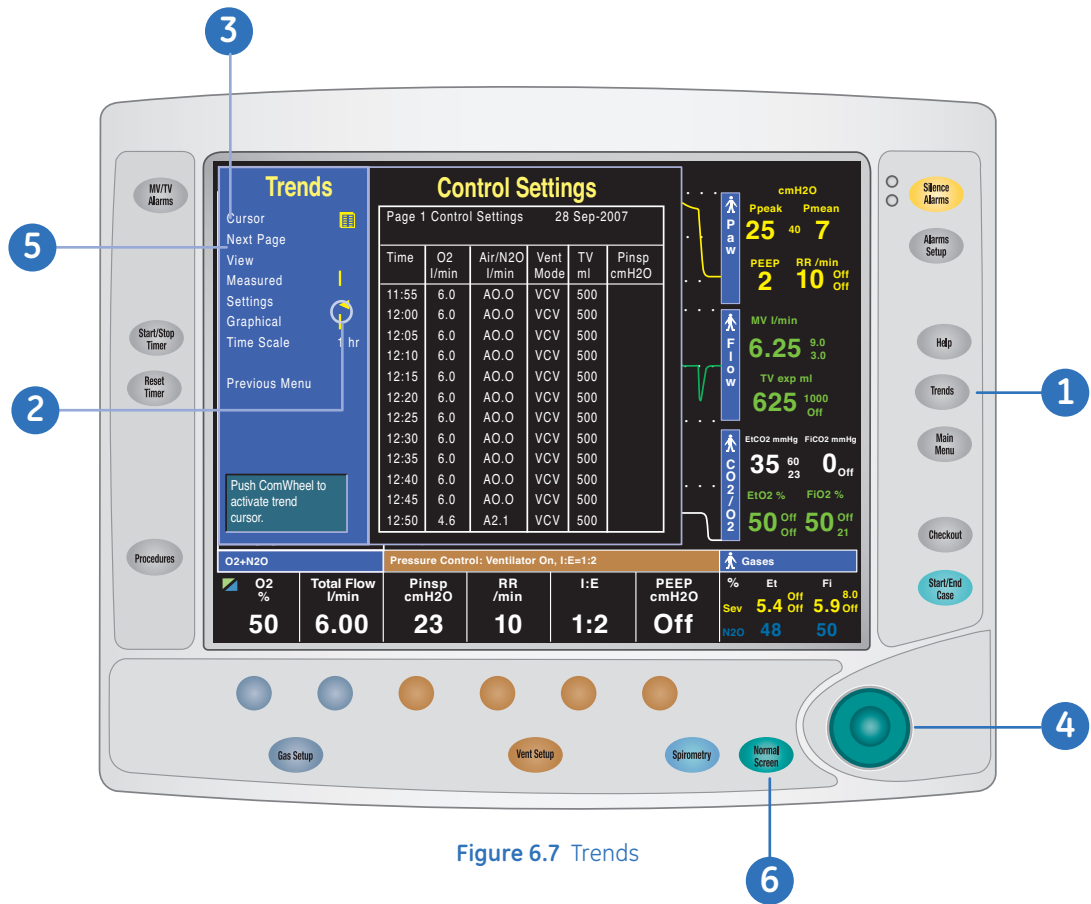

Figure 6.7 Trends

Cardiac Bypass

There are two types of cardiac bypass. **Manual ventilation cardiac bypass** is standard. **VCV cardiac bypass** is optional.

Manual ventilation cardiac bypass suspends alarms for patients on cardiac bypass when the ventilator is not mechanically ventilating. The volume, apnea, low agent, CO₂, and respiratory rate alarms are suspended. The alarms are enabled when cardiac bypass is turned off or mechanical ventilation is started.

Systems with the VCV cardiac bypass option enabled can mechanically ventilate while in VCV mode. The VCV mode is the only ventilation mode available while using VCV cardiac bypass. The volume, apnea, low agent, CO₂, low Paw, and respiratory rate alarms are suspended.



Note! *Manual ventilation cardiac bypass and VCV cardiac bypass modes should only be used when the patient is receiving extra-corporeal oxygenation by means of a heart-lung machine. These modes of ventilation are not intended to provide metabolic levels of ventilation to the patient.*

Using manual ventilation cardiac bypass:

1. Set the Bag/Vent switch to Bag.
2. Push the **Main Menu** key.
3. Set Cardiac Bypass to **On**.

The general message **Cardiac Bypass** shows in the waveforms and in the general message field when manual ventilation cardiac bypass is active.

Using the optional VCV cardiac bypass:

1. Start mechanical ventilation in **VCV** mode.
2. Push the **Main Menu** key.
3. Set Cardiac Bypass to **On**.

The PEEP is set to **5 cmH₂O**. TV settings of less than 170 ml prior to starting cardiac bypass remain at the set **TV**. TV settings of more than 170 ml prior to starting cardiac bypass change to **170 ml**. The general message **VCV Cardiac Bypass** shows in the waveforms and in the general message field when VCV cardiac bypass is active.



Note! PEEP and TV settings can be changed after entering cardiac bypass mode.

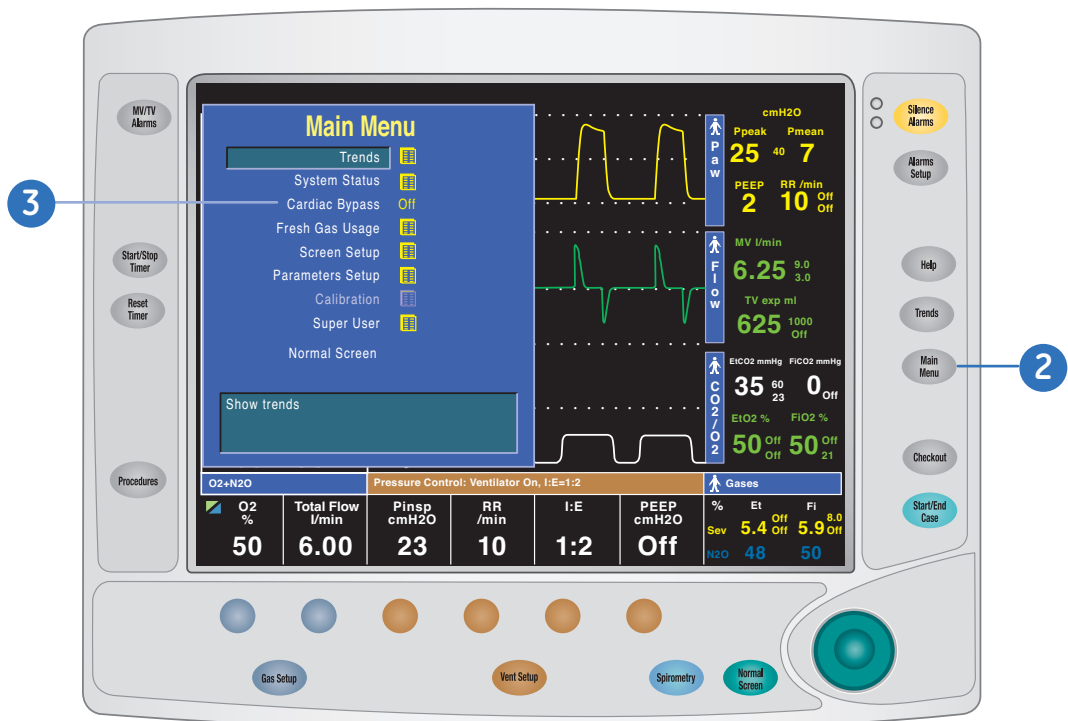

Figure 6.8 Cardiac Bypass

Alarm Management

Overview

Alarms are divided into technical and parameter alarms, and can be **High Priority**, **Medium priority**, or **Informational**. Technical alarms occur regardless of whether a patient is connected to the system. Parameter alarms are calculated limits, and limits set by you in the Alarm Setup menu. These alarms only occur when a patient is connected.

Silencing an alarm stops the audible tone for one hundred-twenty seconds. Pushing the **Alarm Silence** key when no Medium or High priority alarms are active suspends the audible alarm tones for ninety seconds.

Alarm priority is indicated by the color of the alarm message and the alarm LED located next to the alarm silence button.

Some patient parameter alarms, such as **Ppeak high** and **FiO₂ low**, will latch (stay on) even when the alarm condition is corrected. The alarm will remain in this condition until it is acknowledged by pushing the **Silence Alarms** key or until the alarm re-occurs. When the alarm is acknowledged, it is removed from the screen

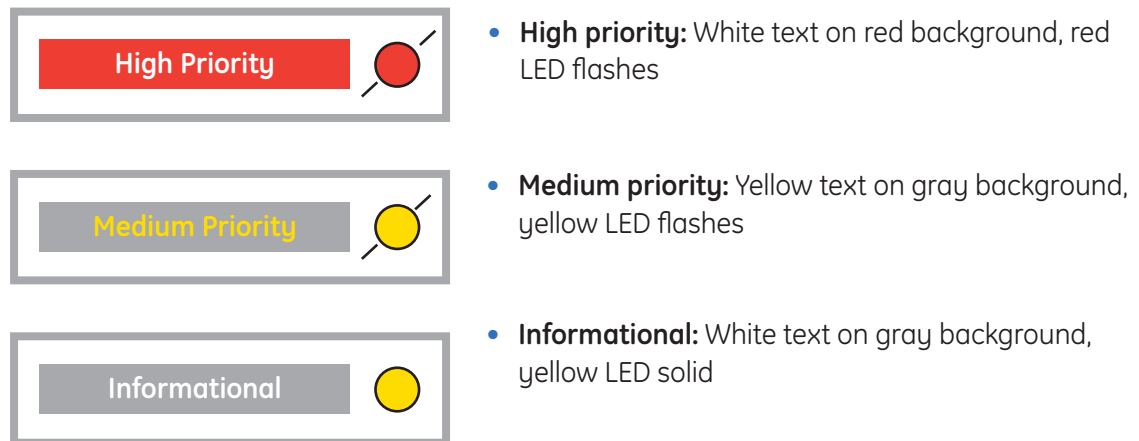

Figure 6.8 Alarm Priority



Note! Refer to your *User's Reference Manual, Section 7: Alarms and Troubleshooting*, for additional alarm information, including ranges and default values, and alarm tests.

Alarm Setup

Push the **Alarm Setup** key to display the corresponding menu. Use the ComWheel to navigate through the menu.

Setting Alarm Limits

1. Push the **Alarms Setup** key.
2. Select **Adjust Settings**.
3. Scroll to the desired **Alarm Limit** and change the value.
4. Push the **Normal Screen** key or select **Back**.

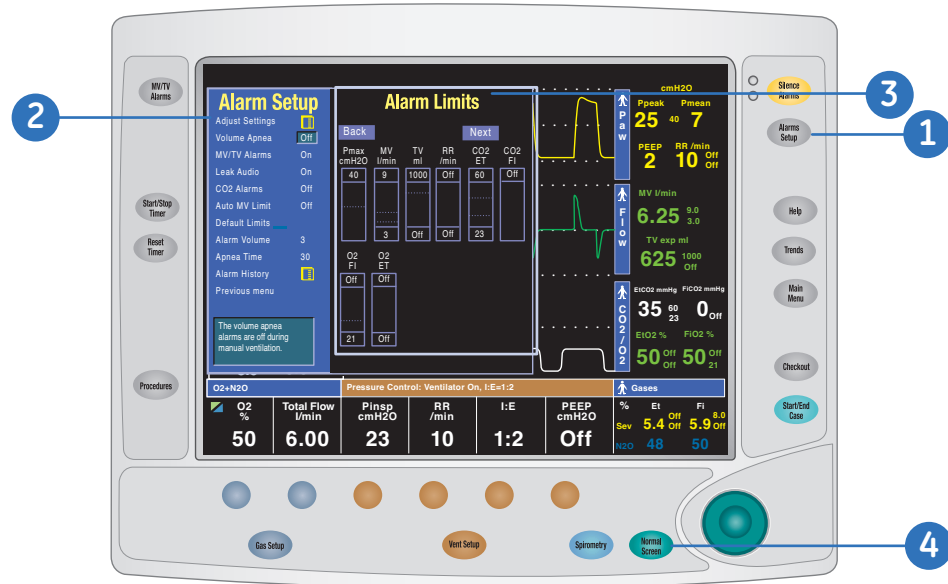

Figure 6.9 Alarm Setup

Alarm Setup Settings

Adjust Settings: Change alarm limits for all adjustable alarms.

Volume Apnea: If enabled from the Super User menu, it is possible to disable the volume apnea alarm during mechanical ventilation. **Volume Apnea Off** shows in the general message field. The volume apnea alarm remains disabled until the Bag/Vent switch is set to ventilator or Volume Apnea is set to **On**.

MV/TV Alarms: Enable/disable volume alarms during manual (bag) ventilation. Settings made during manual ventilation are not retained when mechanical ventilation starts. Settings made during mechanical ventilation are retained when manual ventilation starts.

Leak Audio: Enables/disables audio alarms for small leaks, such as uncuffed endotracheal leaks. Once selected, **low MV alarms** must be enabled.

CO₂ Alarms: Turns off the CO₂ Apnea alarm, EtCO₂ low, EtCO₂ high, FiCO₂ high and **Absorbent OK?** alarms during manual ventilation. The alarms remain disabled until the Bag/Vent switch is set to ventilator, the case is ended, or the CO₂ Alarms is set to **On**.

Auto MV Limit: MV alarm limits can be calculated automatically for mechanical ventilation when in VCV or PCV-VG modes and volume compensation is enabled.

Default Limits: Selecting Default Limits loads the default settings as set from the Super User menu.

Alarm Volume: Changes the audible levels of alarms.

Apnea Time: Choose your delay time for the apnea alarm, from ten to thirty seconds.

Alarm History: View the list of the ten most recent high and medium priority alarms that occurred since the start of the case.

7 Ventilation Modes

Overview

7900 SmartVent

The Avance Carestation uses SmartVent ventilation technology offering Volume Control Ventilation with tidal volume compensation, Pressure Control Ventilation, and electronic PEEP.

The ventilator uses flow sensors to adjust its output for changes in fresh gas flow, small leaks, and gas compression upstream of the breathing circuit. There is adjustment for compression in the patient circuit. The Advanced Breathing System (ABS) has a small circuit volume, optimized for low and minimal flow applications.

Modes

In addition to Volume Control Ventilation (VCV), the Avance can provide Pressure Control Ventilation (PCV), Synchronized Intermittent Mandatory Ventilation (SIMV) with pressure support, Pressure Support Ventilation with Apnea protection backup mode (PSVPro), SIMV with Pressure Control, Pressure Control Ventilation with Volume Guarantee (PCV-VG), and Constant Positive Airway Pressure/Pressure Support Ventilation (CPAP/PSV).

VCV:	Volume Control Ventilation (20-1500 ml)
PCV:	Pressure Control Ventilation (5-60 cmH ₂ O)
SIMV/PSV:	Synchronized Intermittent Mandatory Ventilation (SIMV) with Pressure Support Ventilation (PSV)
PSVPro:	Pressure Support Ventilation with Apnea Backup
SIMV-PC:	Synchronized Intermittent Mandatory Ventilation with Pressure Control
PCV-VG:	Pressure Control Ventilation with Volume Guarantee
CPAP/PSV:	Constant Positive Airway Pressure/Pressure Support Ventilation

The following pages will describe each mode in greater detail.

Circuit Compliance Compensation

The ventilator adjusts gas delivery and monitoring to compensate for the compliance of the patient circuit if:

- The system has a gas analyzer installed
- The Circuit Compliance is set to **On** in the **Super User >Ventilator Settings** menu
- The Machine Check is completed after the system is turned on

Circuit compliance is determined during the Machine Check-System check or when the System check is done as an individual check. Circuit compliance must be set to **On** by the Super User for the Circuit Compliance compensation function to be active.

In volume modes, circuit compliance compensation increases the volume delivered at the inspiratory port by taking into consideration the circuit compliance value. In all modes, circuit compliance compensation adjusts the volume measurements. Circuit compliance compensation provides consistent ventilator accuracy at the patient circuit.

Volume Controlled Ventilation (VCV)

Volume Controlled Ventilation delivers a set volume to the patient during the entire inspiratory phase. The ventilator calculates a flow based on the set tidal volume and the length of the inspiratory time to deliver that tidal volume. It then adjusts that output by measuring delivered volumes at the inspiratory flow sensor. The inspiratory pause is selectable, and can be set at 0-65% of inspiratory time.

Since the ventilator adjusts output, it can compensate for breathing system compliance, fresh gas flow, and moderate breathing system leaks.

Observe the pressure waveform. A typical volume-controlled pressure waveform increases throughout the entire inspiratory period, and rapidly decreases at the start of expiration. Notice the “shark fin” pressure waveform pattern and the square inspiratory flow pattern below.



Note! Pressure becomes the dependent variable in VCV. Volume can be changed, and the pressure changes depending on delivered volume and the compliance of the patient.

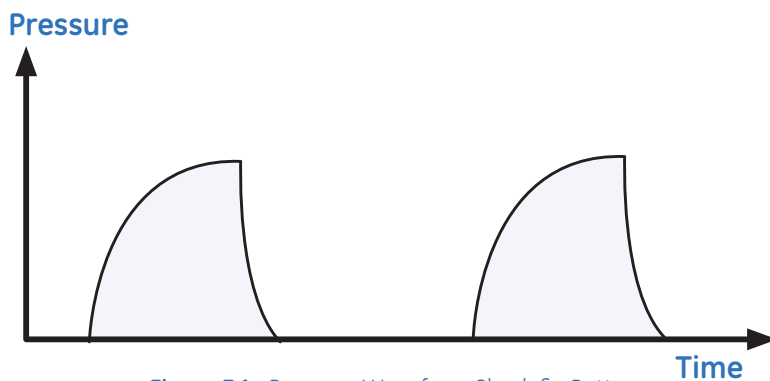

Figure 7.1 Pressure Waveform Shark fin Pattern

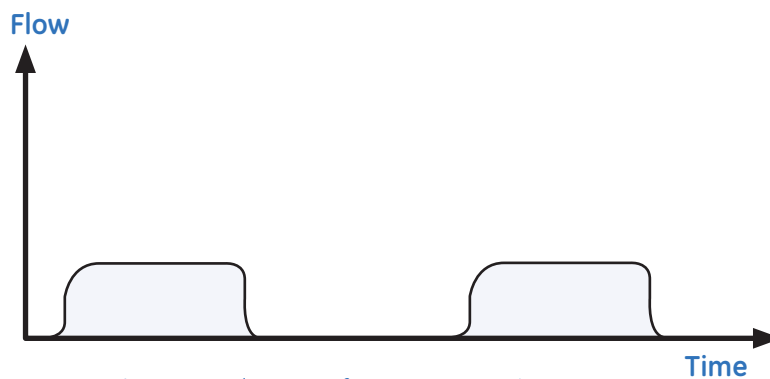

Figure 7.2 Flow Waveform Square Inspiratory Pattern

Volume Control: Ventilator On			
TV ml	RR /min	I:E	PEEP cmH2O
500	10	1:2	Off

Figure 7.3 Volume Control Settings on Display

Pressure Controlled Ventilation (PCV)

Pressure Controlled Ventilation builds pressure quickly in the patient circuit to the preset level and maintains it until the end of the inspiratory phase. PCV also compensates for small system leaks.

The ventilator calculates the inspiratory time from the respiratory rate and I:E ratio settings. A high initial flow pressurizes the circuit to the set inspiratory pressure. The flow then decreases to maintain the set pressure (P_{insp}). Selectable rise time (1 is slowest, 10 is fastest) controls how quickly targeted pressure is reached. Default setting is **Auto**. Adjustable rise time is also available for **PSV** and **PCV-VG** modes.

Pressure sensors in the system measure patient airway pressure. The ventilator automatically adjusts the flow to maintain the set inspiratory pressure.

Observe the exhaled volumes and microprocessor-controlled decelerating inspiratory flow. Note that volume becomes the dependent variable in PCV. Pressure can be changed, with the volume changing depending on the compliance of the patient.

Changing any of the following settings, **Set Pressure**, **Rate** or **I:E Ratio**, individually or in combination, will affect the minute volume.

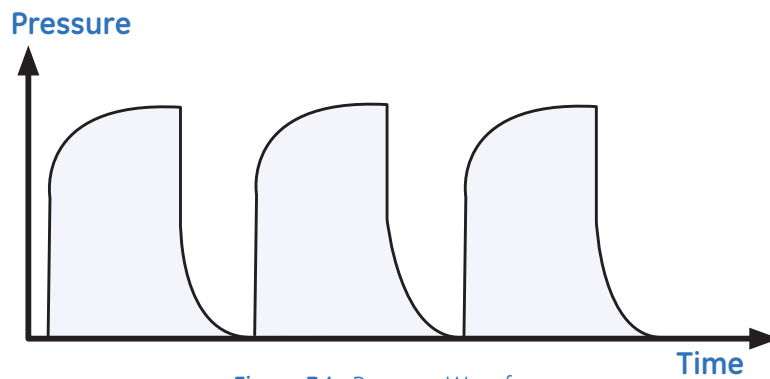

Figure 7.4 Pressure Waveform

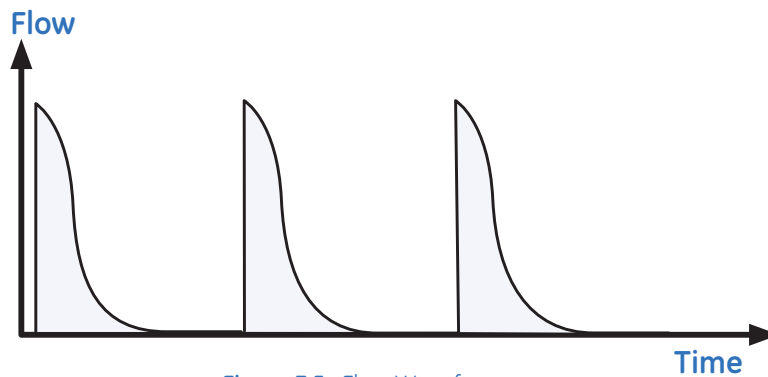

Figure 7.5 Flow Waveform

Pressure Control: Ventilator On			
P _{insp} cmH ₂ O	RR /min	I:E	PEEP cmH ₂ O
23	10	1:2	Off

Figure 7.6 Pressure Control Settings on Display

SIMV/PSV

SIMV is a mode in which periodic (2-60) volume breaths are delivered to the patient at preset intervals (time-triggered). Between the machine-delivered breaths, the patient can breathe spontaneously at the rate, tidal volume, and timing that the patient desires.

In SIMV, the spontaneous breaths can be pressure-supported to assist the patient in overcoming the resistance of the patient circuit and the artificial airway. When the Psupport level is set, the ventilator will deliver the pressure support level to the patient during inspiration. PEEP can also be used in combination with this mode.

Pressure limit setting can be found in the SIMV/PSVPro setup menu.

SIMV/PSV: Ventilator On			
TV ml	RR /min	Psupport cmH ₂ O	PEEP cmH ₂ O
300	10	12	Off

Figure 7.7 SIMV Control Settings on Display

Psupport replaces I:E Ratio
(Range: off, 2-40cmH₂O)

SIMV Trigger Window and Sensitivity

The trigger window setting is a percentage of end expiratory time. At the specified time interval, the ventilator will wait for the next inspiratory effort from the patient. The sensitivity of this effort is adjusted using the flow trigger level, measured by the inspiratory flow sensor, and used to start a PSV breath, and to synchronize the SIMV breaths. An adjustable negative flow (0.2-10 L/min) is needed to trigger a mechanical breath (sensitivity).

When the ventilator senses the beginning of inspiration it synchronously delivers a volume breath using the set tidal volume, and inspiratory time that is set on the ventilator. If the patient fails to make an inspiratory effort during the trigger window time interval, the ventilator will deliver a machine breath to the patient.

The ventilator will always deliver the specific number of breaths per minute that you have set.

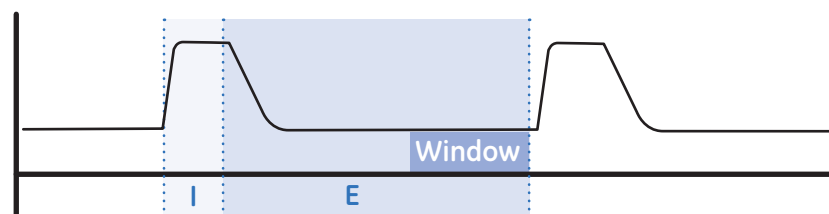

Figure 7.8 Example of Trigger Window

PSV Pro

PSVPro is a spontaneous mode of ventilation that provides a constant pressure once the ventilator senses that the patient has made an inspiratory effort.

In this mode, you set the Pressure Support (P_{support}) and PEEP levels. The patient establishes the rate and inspiratory flow and time. The tidal volume is determined by the pressure, lung characteristics, and patient effort.

PSVPro uses an inspiratory termination level to establish when the ventilator will stop the pressure-supported breath and cycle to the expiratory phase. The inspiration termination level is user adjustable from **5%** to **75%**. This parameter sets the percent of the peak inspiratory flow that the ventilator uses to end the inspiratory phase of the breath, and to cycle into the expiratory phase.

- If the inspiration termination is set to 30% then the ventilator will stop inspiration when the flow decelerates to a level equal to 30% of the measured peak inspiratory flow
- The lower the setting, the longer the inspiratory time, and conversely, the higher the setting, the shorter the inspiratory phase

PSVPro: Ventilator On, PEEP = Off cmH2O			
P _{insp} cmH2O	RR /min	T _{insp} s	P _{support} cmH2O
15	12	1.50	20

Figure 7.9 PSV Pro Settings on Display



Note! Ventilator settings that are gray instead of white are not currently active. When the settings do become active they will turn white.

PSVPro (Protection Backup Mode)

An apnea backup mode is provided in the event the patient stops breathing. When setting this mode, you adjust the inspiratory pressure (P_{insp}), respiratory rate, and the inspiratory time (T_{insp}). As long as the patient is triggering the ventilator and the apnea alarm does not activate, the patient will get pressure-supported breaths and the ventilator will not deliver machine breaths.

If the patient stops triggering the ventilator for the set apnea delay time (adjustable between **10-30** seconds), the apnea alarm will activate and the ventilator will automatically switch to the backup mode. The backup mode is **SIMV-PC**. Once in this mode the ventilator will begin delivering machine Pressure Control breaths at the inspiratory pressure level, time, and rate that you have set. If, during this mode, the patient takes spontaneous breaths in between the machine breaths, the patient will receive pressure-supported breaths.

When the ventilator switches to the backup mode, the alarm text **Backup Mode active** shows as an information message until PSVPro is reinstated or until another ventilation mode is selected. PSVPro mode automatically resumes when the ventilator registers the number of consecutive patient-triggered breaths set for the Exit Backup setting. When Exit Backup is set to **Off**, the user must reselect the PSVPro mode to reactivate PSVPro. Upon returning to PSVPro the ventilator immediately begins providing pressure supported breaths to the patient using the established settings. Spontaneous breaths that occur during this mode are indicated by a color change in the waveform.

SIMV-PC: Ventilator On, PEEP = Off cmH2O			
P _{insp} cmH2O	RR /min	T _{insp} s	P _{support} cmH2O
12	10	1.70	12

Backup Mode active

Figure 7.10 Example of Back-up mode SIMV-PC

SIMV-PC

SIMV, Pressure Controlled mode is a mode in which synchronized, pressure-controlled breaths are set by the respiratory rate. This mode combines mandatory breaths with spontaneous breath support.

- If a patient triggered event occurs within the synchronization window, a new pressure-controlled breath is initiated
- If a patient triggered event occurs elsewhere during the expiratory phase, a pressure-supported spontaneous breath is provided at the pressure support level that was set. This can be seen in the pressure supported breath in the diagrams below

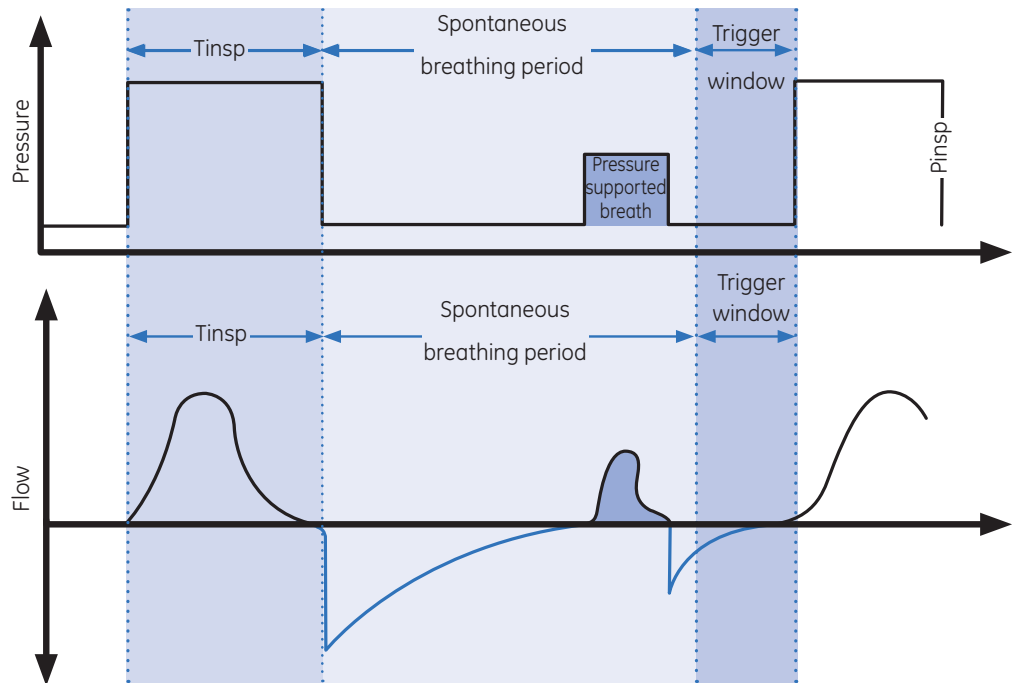

Figure 7.11 Example of Pressure and Flow Waveforms

SIMV-PC: Ventilator On, PEEP = Off cmH2O			
P _{insp} cmH2O	RR /min	T _{insp} s	P _{support} cmH2O
15	12	1.50	11

Figure 7.12 Example of SIMV-PC settings

PCV-VG

PCV-VG (Pressure Control Ventilation with Volume Guarantee) is a mode in which a tidal volume is set, and the ventilator will adjust the inspiratory pressure needed to deliver the set volume so that the lowest pressure is used.

This mode delivers breaths with the efficiency of pressure controlled ventilation, yet compensates for changes in the patient’s lung characteristics.

PCV-VG begins by first delivering a volume breath at the set tidal volume. The patient’s compliance is determined from this volume breath and the inspiratory pressure level is then established by the next PCV-VG breath.

The pressure range that the ventilator will use is between the PEEP + 2 cmH₂O level on the low end and 5 cmH₂O below P_{max} on the high end. The inspiratory change between breaths is a maximum of plus or minus 3 cmH₂O.

PCV-VG Mode settings

- Tidal volume
- Respiratory rate
- I:E ratio
- PEEP
- P_{max}
- Rise rate

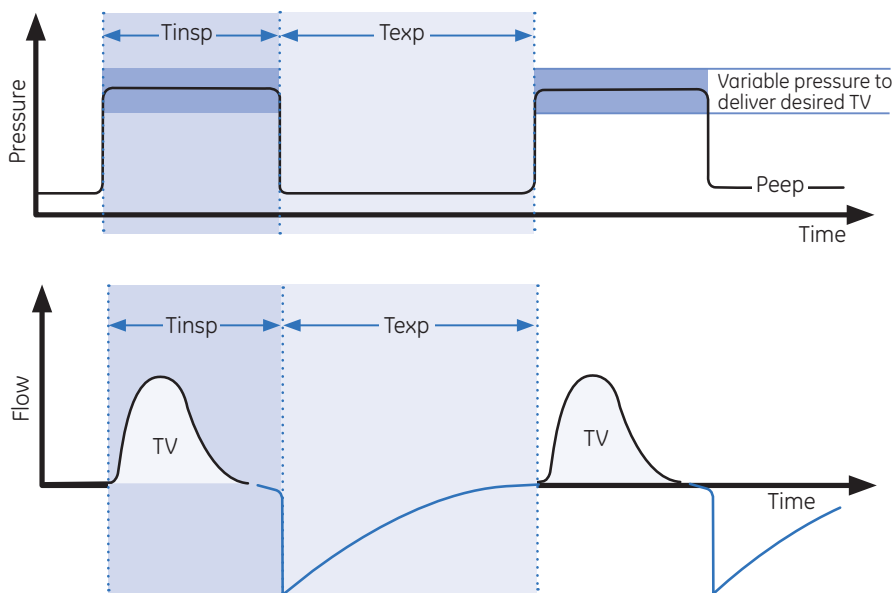

Figure 7.13 Example of PCV-VG Waveforms

PCV-VG: Ventilator On			
TV ml	RR /min	I:E	PEEP cmH ₂ O
500	10	1:2	Off

Figure 7.14 Example of PCV-VG settings

CPAP/PSV

Constant positive airway pressure/pressure support ventilation mode is used on spontaneously breathing patients. This mode of ventilation provides a constant support pressure once the ventilator senses that the patient has made an inspiratory effort. In this mode, the clinician sets the Pressure Support (P_{support}) and PEEP levels. The patient establishes the rate, inspiratory flow and inspiratory time. The tidal volume is determined by the pressure, lung characteristics and patient effort.

CPAP/PSV uses an inspiration termination level that establishes when the ventilator will stop the pressure supported breath and cycle to the expiratory phase. The inspiration termination level is user adjustable from 5% to 75%. This parameter sets the percent of the peak inspiratory flow that the ventilator uses to end the inspiratory phase of the breath and to cycle into the expiratory phase. If the inspiration termination is set to 30% then the ventilator will stop inspiration when the flow decelerates to a level equal to 30% of the measured peak inspiratory flow. The lower the setting the longer the inspiratory time and conversely, the higher the setting the shorter the inspiratory phase.

If the spontaneous inspiratory effort does occur within the delay period, the ventilator delivers pressure controlled breaths with the preset inspiratory pressure to bring the breath rate up to the minimum rate. The delay period calculation is $60 \text{ s}/\text{minimum rate} + ([60 \text{ s}/\text{minimum rate}] - \text{previous breath interval})$.

The inspiratory support pressure and the inspiratory pressure settings are linked at the start of each case. When the inspiratory support pressure setting is changed, the inspiratory pressure setting is automatically adjusted to match the inspiratory pressure setting. The link can be broken by changing the P_{insp} setting through the Vent Setup menu during the case.

Spontaneous breaths that occur during this mode are indicated by a color change in the waveform.

CPAP/PSV settings

- P_{support}
- PEEP
- Flow trigger
- End of breath
- P_{max}
- P_{insp}
- Minimum RR
- T_{insp}
- Rise rate

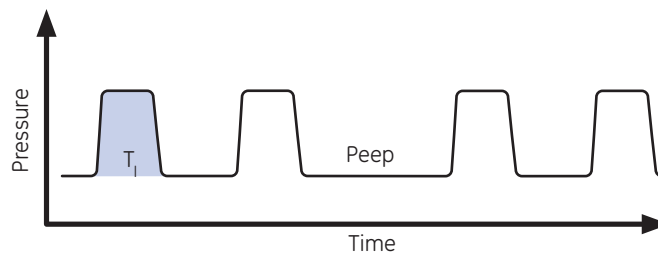

Figure 7.15 CPAP/PSV Waveform

CPAP/PSV: Ventilator On, P _{insp} = 20 cmH ₂ O, T _{insp} = 1:7 s			
P _{support} cmH ₂ O	Flow Trigger /min	PEEP cmH ₂ O	Minimum RR /min
5	2.0	5	12

Figure 7.16 Example of CPAP/PSV Settings

8 Spirometry

Overview

Use the Spirometry menu to:

- Set the loop type
- Adjust the loop scaling
- Access the Spirometry Setup menu
- Save a loop to memory
- View a saved loop
- Erase a saved loop

There are three types of spirometry loops: Pressure-Volume (P-V), Flow-Volume (F-V) and Pressure-Flow (P-F). The spirometry loops show in the spirometry window and can be set to show alongside the waveforms as the split screen.

Setting the Loop Type

1. Push the **Spirometry** key.
2. Select **Loop Type** and set the loop type.
 - Set to **P-F** for Paw-Flow.
 - Set to **F-V** for Flow-Volume.
 - Set to **P-V** for Paw-Volume

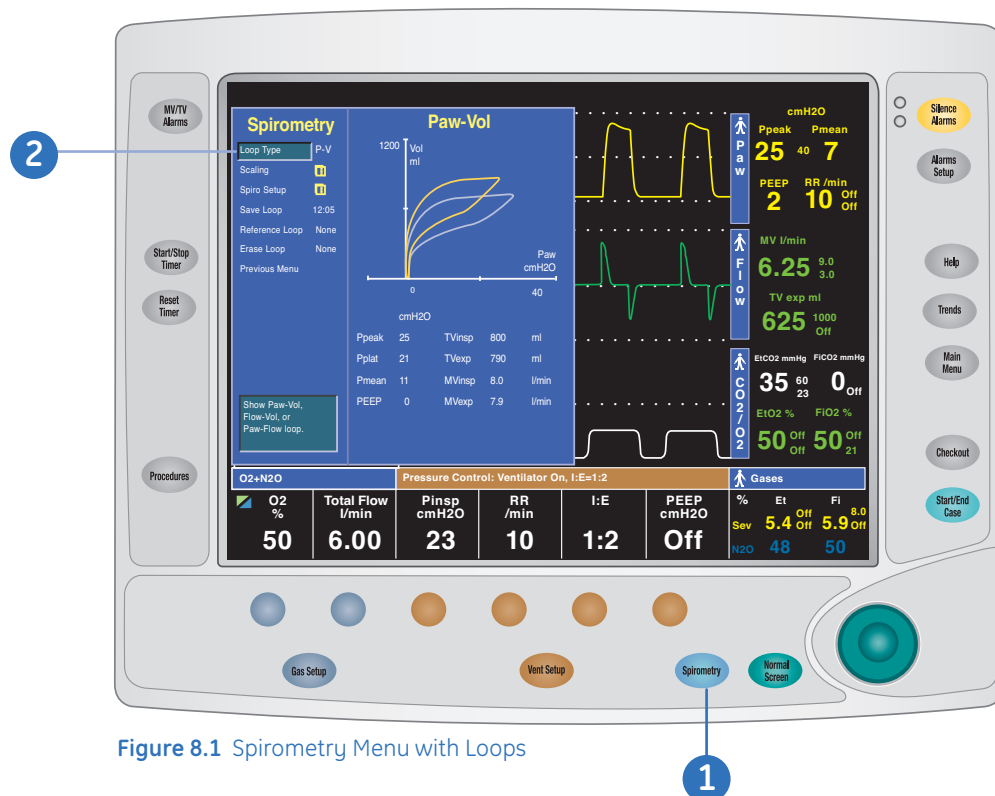

Figure 8.1 Spirometry Menu with Loops

Setting Loop Graph Scaling

Use the Scaling menu to set the scales of the spirometry loop graph. The available settings for the volume, Paw, and flow graph axes are dependent on the set patient type of adult or pediatric.

- 1. Auto:** Automatically adjusts the loop graph scaling based on the minimum and maximum breath reading.
- 2. Linked:** When you change one of the scales, the remaining two scales automatically change based on the one set scale.
- 3. Indep:** Allows the volume, Paw and flow axes of the loop graph to be changed separately.

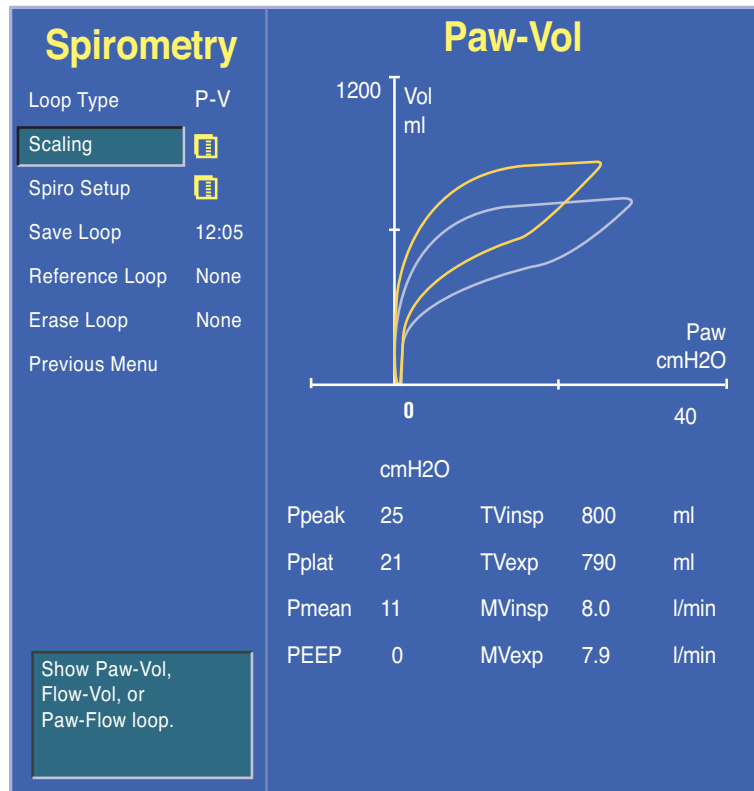

Figure 8.2 Spirometry Menu -Scaling Option

Spirometry Setup

Use the Spirometry Setup menu to:

- Set the patient and sensor type
- Select a data source
- Set the spirometry loop type
- Change the volume shown on the spirometry split screen to **MVexp** or **TVexp**
- Set split-screen view
- Access the Paw and MVexp alarm limits

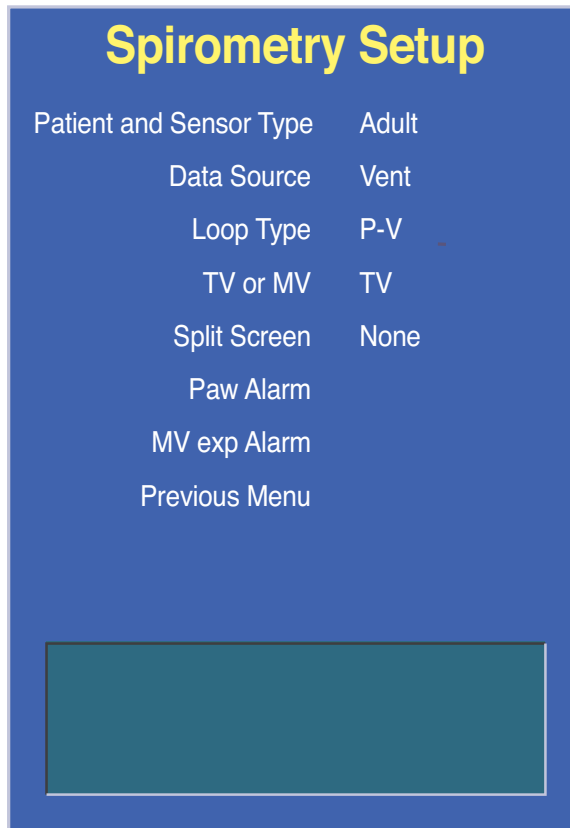

Figure 8.3 Spirometry Setup Menu

Setting Patient and Sensor Type

Patient and sensor type refer to the style of airway adapter used with the airway module. If spirometry data is obtained from the airway module, make sure that the sensor type matches the type airway adapter used.

1. Push the **Spirometry** key.
2. Select **Spiro Setup > Patient and Sensor Type**.
3. Select **Adult** or **Pedi** depending on the sensor used.
 - Adult refers to the D-lite sensor
 - Pedi refers to the Pedi-lite sensor



Note! Make sure that the set sensor type corresponds to the type of airway adapter in use. If the sensor type is not set correctly, the information displayed may not be accurate.

Selecting a Data Source

Several monitoring parameters can be obtained from the ventilator or from the airway module. If information is not available through the airway module, information comes from the internal ventilator sensors. If the internal ventilator sensor readings disagree with the airway module sensor readings, the associated alarm occurs.

When the airway module is selected as the data source, make sure that a D-lite or Pedi-lite sensor is properly connected on the airway module. If the sensor is not properly connected, the waveform shows no flow and the gas monitor samples room air.

1. Push the **Spirometry** key.
2. Select **Spiro Setup > Data Source**.
3. Select **Patient** or **Vent** as the primary source for information.
 - If **Patient** is selected, the airway module will be the first source for information
 - If **Vent** is selected, the internal sensors of the ventilator will be the first source for information
4. Push the **Normal Screen** key or select **Previous Menu**.

Setting Spirometry Volume Type

The volume shown on the spirometry split screen can be set to minute volume or tidal volume.

1. Push the **Spirometry** key.
2. Select **Spiro Setup**.
3. Select **TV** or **MV**.
 - Set to **TV** to show TVinsp on the spirometry split screen
 - Set to **MV** to show MVexp on the spirometry split screen
4. Push the **Normal Screen** key or select **Previous Menu**.

Setting Spirometry Split Screen

Spirometry loops can be viewed alongside the waveforms on the normal screen.

1. Push the **Spirometry** key.
2. Select **Spiro Setup**.
3. **Select Split Screen > Spiro**.
4. Push the **Normal Screen** key.

Storing and Erasing Spirometry Loops

Spirometry loops can be saved, viewed, and erased through the **Spirometry** menu.

1. Push the **Spirometry** key.
2. To store a loop to memory, select **Save Loop**. Up to six loops can be saved.
3. To view a saved loop, select **Reference Loop** and the time at which the loop was saved.
4. To erase a saved loop, select **Erase Loop** and the time at which the loop was saved.

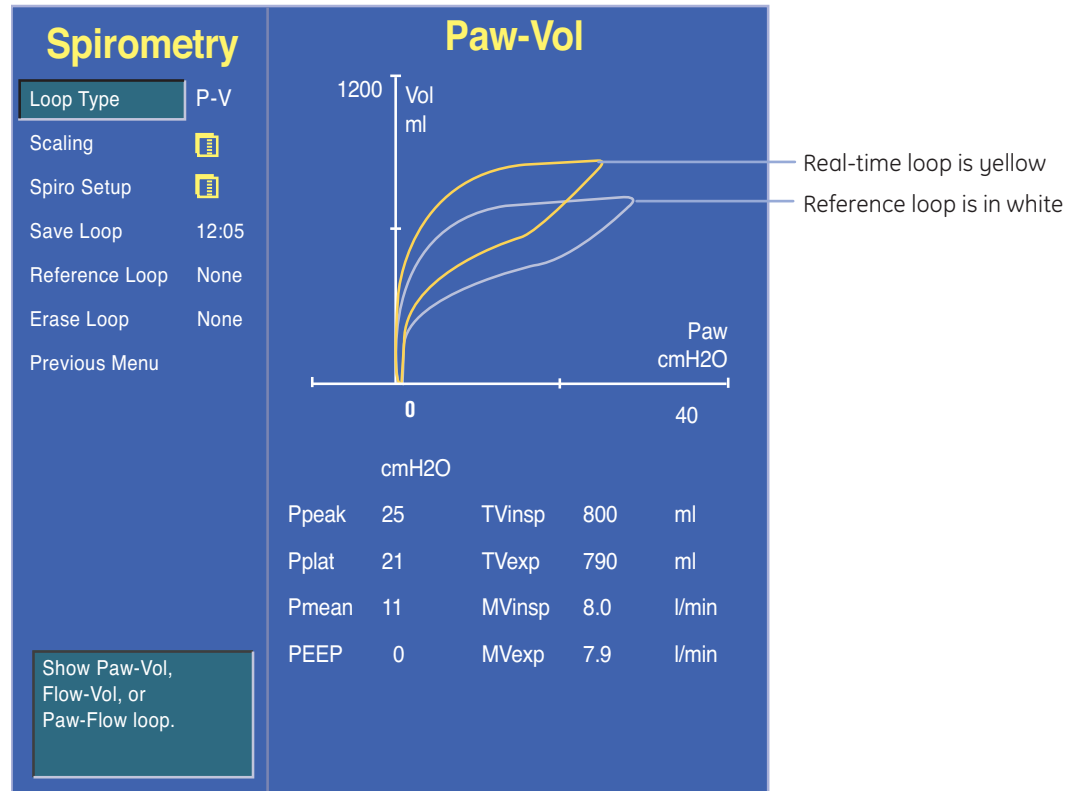

Figure 8.4 Spirometry Loops

9 Procedures

Overview

Push the **Procedures** key to display the **Procedures** menu, and then use the ComWheel to navigate the menu.

Use the Procedures menu to pause the gas flow, perform or change the settings for a vital capacity procedure, or perform or change the settings for a cycling procedure.



Note! *Vital Capacity* and *Cycling* show in the menu only if they are set to **Yes** in the Super User menu. *Vital Capacity* and *Cycling* are only selectable during mechanical ventilation.

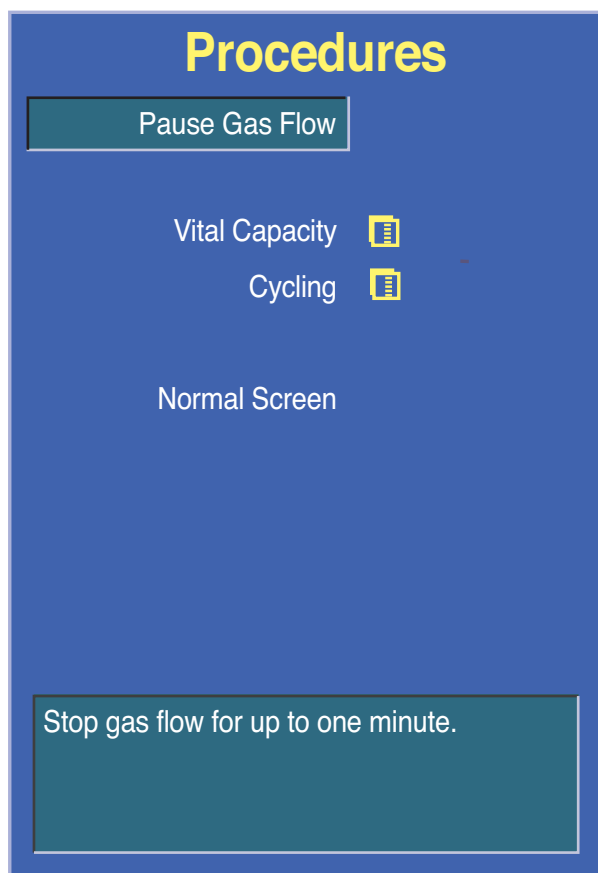

Figure 9.1 Procedures Menu

Pause Gas Flow

Use Pause Gas Flow to temporarily suspend the flow of gas during a case. Using Pause Gas Flow while the breathing circuit is disconnected prevents the flow of gas into the room. Pause Gas Flow is available during both mechanical ventilation and manual ventilation.

From the Procedures menu, push the ComWheel while **Pause Gas Flow** is selected to suspend the flow of gas.

The amount of time remaining in the gas flow pause shows in the window. The gas flow will stop for one minute and then resume. If mechanical ventilation is on, mechanical ventilation will stop for one minute and then resume. Stop the gas flow pause any time during the pause by selecting **Restart Gas Flow**.

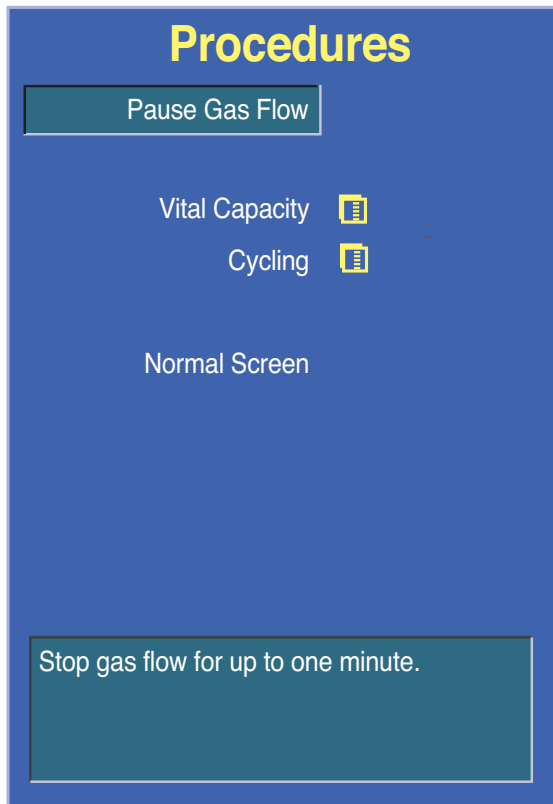

Figure 9.2 Pause Gas Flow Selection

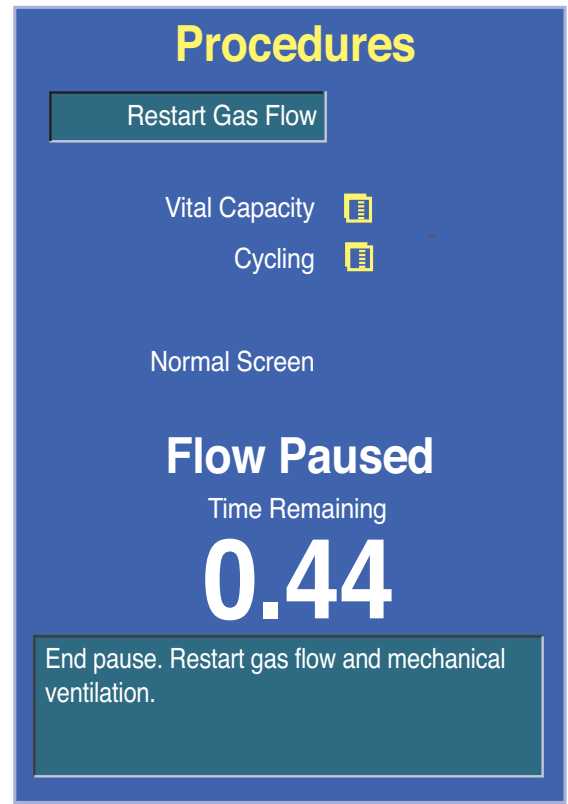

Figure 9.3 Restart Gas Flow Selection

Vital Capacity

Use the Vital Capacity procedure to deliver a pressure breath for a set time. The Vital Capacity procedure provides a simple way to deliver one pressure breath during mechanical ventilation without making multiple ventilator setting changes. The **PEEP on Exit** setting provides a way to change the ventilation PEEP setting automatically at the end of the Vital Capacity procedure.

The **Pressure Hold**, **Hold Time**, and **PEEP on Exit** settings can be preset by the Super User. These settings can be changed by the user before starting the procedure.



Note! **PEEP on Exit** will show only if it is set to **Yes** in the Super User menu.

Using vital capacity

From the Procedures menu, scroll to **Vital Capacity** and press the ComWheel. Push the ComWheel while **Start** is selected to deliver one pressure breath at the given set pressure (Pressure Hold) and hold time. PEEP is set to the **PEEP on Exit** setting. If the procedure is stopped before completion, the **PEEP on Exit** setting is not used.

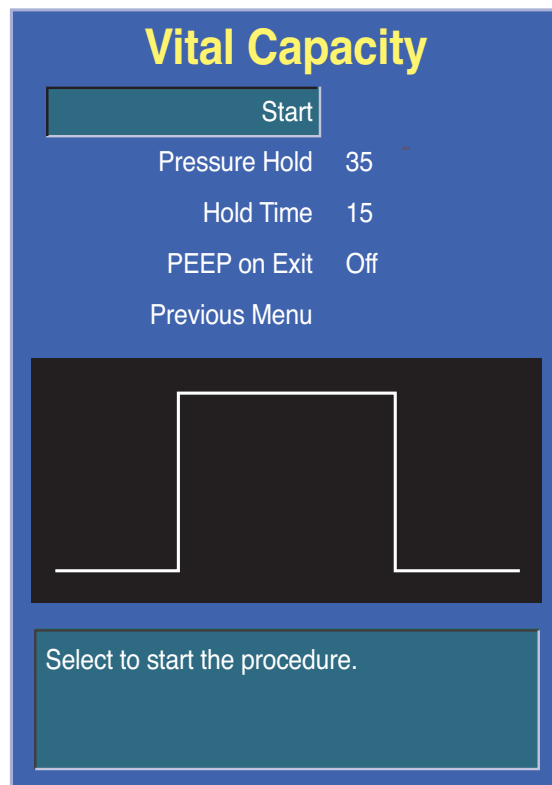

Figure 9.4 Vital Capacity Menu

Vital capacity settings

Pressure Hold can be set to between **20** and **60** cmH₂O. Hold Time can be set to between **10** and **60** seconds. PEEP on Exit can be set to **Off**, or between **4** and **30** cmH₂O.

Cycling

Use the Cycling procedure to delivery pressure breaths through a series of ventilation steps. The Cycling procedure provides a flexible way to deliver pressure breaths during ventilation without making multiple ventilator setting changes. Up to seven preset steps with multiple breaths are available

Each procedure defaults steps and ventilation settings can be preset by the Super User. The ventilation settings of each step can be changed by the user before starting a procedure.

Using Cycling

From the Procedures menu, scroll to **Cycling** and press the ComWheel. By default, **Start and Procedure 1** are selected. Press the ComWheel while **Start** is selected to begin **Procedure 1**, or scroll to another Procedure and select **Start**. The procedure will begin and the procedure progress will show in the procedure window. Stop the procedure anytime by selecting **Stop**.

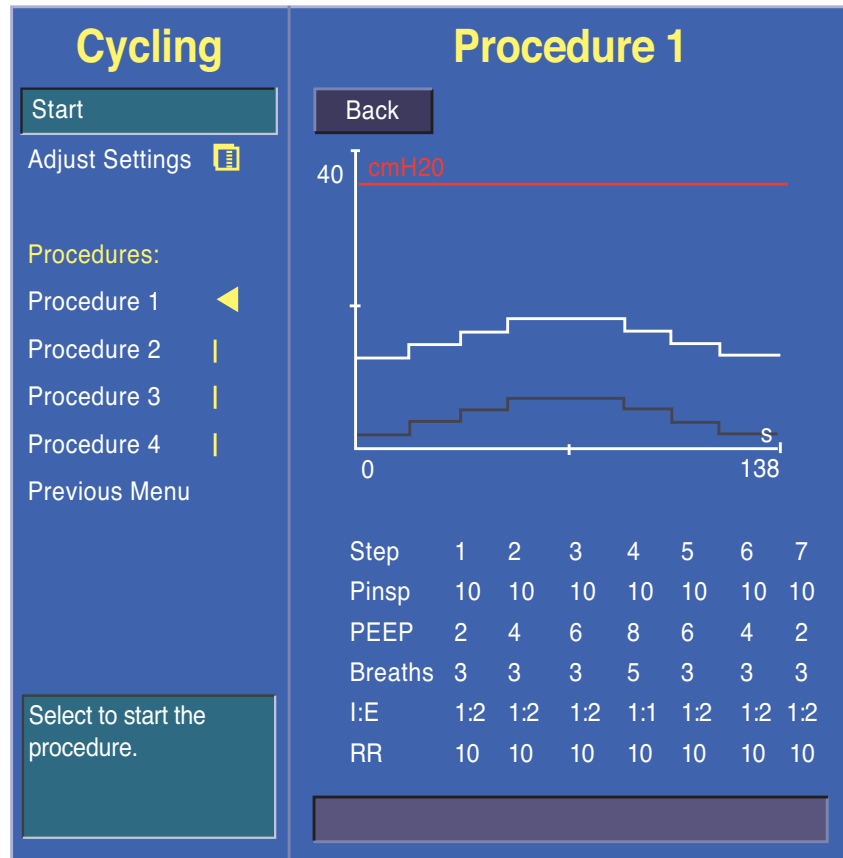

Figure 9.5 Cycling Menu

Changing Cycle Settings

Select the procedure to change, and then select **Adjust Settings**. Push the ComWheel to enter the adjust window. Use the ComWheel to navigate the adjustment window and change a value. Repeat to change settings as desired. When finished changing settings, select **Confirm**.

10 System Checkout

Checkout Menu

The Checkout menu shows on the display after turning on the system. To access the Checkout menu between cases, push the **Checkout** key. Step-by-step instructions show in the right window next to the Checkout menu during the checks. Use the Checkout menu to:

- Perform a Machine Check
- Perform any of the individual checks
- View the Check Log
- Start a case

Checkout		Instructions	
Machine Check	[Icon]	IN AN EMERGENCY, select Bypass checks.	
Individual Checks		1. Connect Scavenging.	
System	[Icon]	2. Open and close cylinders.	
Circuit	[Icon]	3. Connect a patient circuit.	
Circuit O2	[Icon]	4. Check the absorber and absorbent.	
Low P Leak	[Icon]	5. Select a check from the menu.	
Check Log	[Icon]	6. Complete instructions and start check.	
Start Case		7. Automatic check beeps if action is required.	
Do the anesthesia system checkout		System	Pass 28-Sep-2011 11:28
		Circuit	Pass 28-Sep-2011 11:29
		Circuit O2	Done 28-Sep-2011 11:29
		Low P Leak	Pass 28-Sep-2011 13:35

Figure 10.1 Machine Check

Machine Check

The Machine Check or the individual checks must be performed at least once within every twenty-four period. Perform the Machine Check at the start of each day. The machine check runs automatically and beeps to indicate when it is finished or if interaction is required.

The Machine Check does a Machine Check - System check, Machine Check - Circuit check, and a Machine Check - Circuit O₂ cell check (if circuit O₂ cell is present). When one of the checks is completed, the next check begins.



Note! Any cassette may be used during the check. Use a non-desflurane cassette during the check to test the full functionality of the internal electronic control unit.

1. Turn the System switch to **On**.
2. Select **Machine Check** and follow the instructions.
3. If a check fails, follow the instructions to perform a recheck or accept the results.
4. When the Machine Check is completed, start a case.



Note! In case of a patient emergency, the Machine Check may be bypassed by selecting **Start Case** from the Checkout menu. The general message **Please Do Checkout** is displayed if a Machine Check is not completed with passing results within twenty-four hours.

Machine Check - System

The Machine Check - System checks the Bag/Vent switch, proper gas supply pressures, ventilator operation and leak, battery and electrical power, circuit compliance, and flow control operation. This is a two-step check.

1. Set Bag/Vent switch to Vent.
2. Open patient "Y".
3. Calibrate the flow sensors. Make sure the flow sensors are securely latched when they are reinserted.
4. Select **Start**. The display shows the checks being run.
 - The system beeps when this portion of the check is done
 - The results are shown on the display
5. Make sure the bellows is fully collapsed.
6. Occlude the patient "Y".
8. Select **Continue**. The display shows the check is being run.
9. When the check passes, the next check will start.

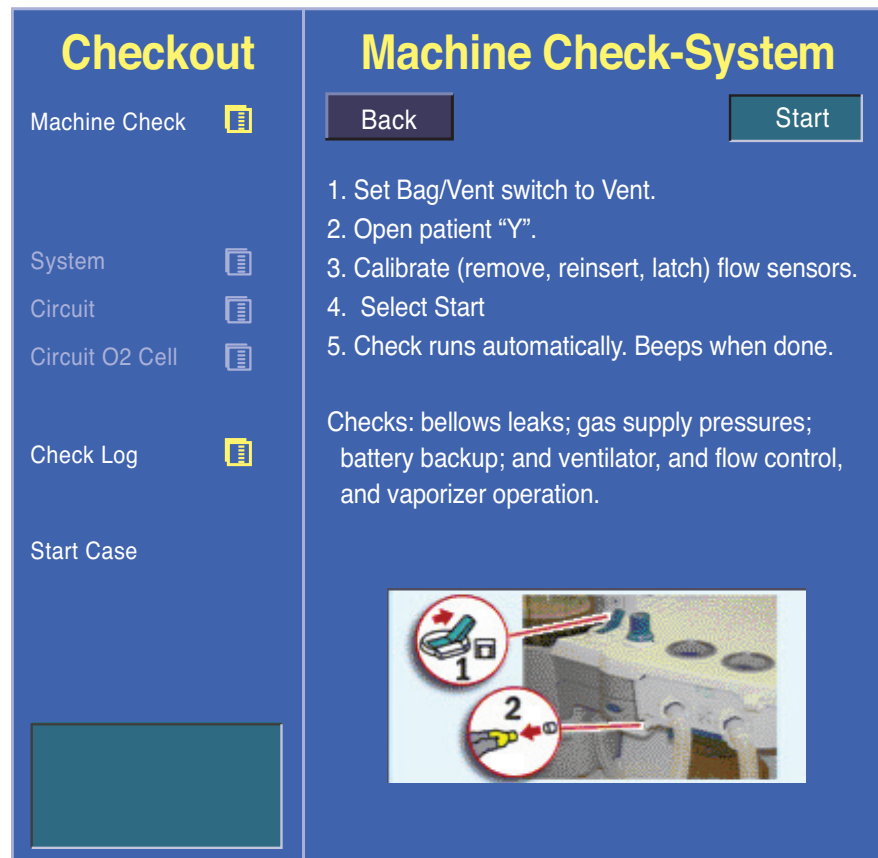

Figure 10.2 Machine Check - System

Machine Check - Circuit

The Machine Check - Circuit checks the Bag/Vent switch, proper gas supply pressures, airway pressure measurement transducer, APL valve, and manual circuit leak.

1. Occlude the patient "Y".
2. Set Bag/Vent switch to Bag.
3. Set the APL Valve halfway between **30** and **70**.
4. Select **Start**. The display shows the checks being run.
 - The system beeps when this portion of the check is done
 - The results are shown on the display
5. When the check passes, the next check starts.

Machine Check - Circuit O₂

The Machine Check - Circuit O₂ check measures the O₂%.

1. Open the patient "Y".
2. Set the Bag/Vent switch to Vent.
3. The display will show the O₂%. DO NOT select **Done** when 21 is first displayed. Allow the reading to stabilize, then select **Done**. Calibrate O₂ cell if necessary.

Machine Check - Monitor

When External Gas Monitor is set to **Yes** by the Super User, the Machine Check-Monitor check occurs. This check is not a test. This check is a reminder to connect a respiratory gas monitor.

Low P Leak

The Low P Leak check is not an automated part of the Machine Check. It may be selected as an individual option from the Checkout menu.

The positive pressure Low P Leak check measures machine leaks before the breathing system, between the common gas outlet and high pressure pneumatics, including the gas mixer and vaporizer. It measures low pressure pneumatic leaks with a pass/fail limit of 50 ml.



Note! Make sure that the vaporizers to be used during the case are mounted on the machine and turned off.

1. Occlude the inspiratory (right-hand) port using the provided green plug.
2. Select **Start**.
3. The display shows the checks being run. The system beeps when the check is done.
4. Repeat the check once for each vaporizer with one vaporizer turned on at a time.
5. When the checks pass, turn the vaporizer off.
6. Open the inspiratory port and reconnect the breathing circuit.
7. Select another check or select **Start Case** to go to the Start Case menu.



Note! The provided plug should be green and flat on one side. If the plug is red and two-sided, it should not be used and should be discarded.

Check Log

You can determine when the last check was performed by utilizing the ComWheel, scrolling down to check log and looking at the last time and date that each step was performed.

Start Case

1. Set the Bag/Vent switch to Bag.
2. If you have just completed a Machine or Individual Check, select **Start Case** from the Checkout menu. If not, push the **Start/End Case** key to go to the Start Case menu.

11 Assembly and Cleaning

Advanced Breathing System

Assemble and disassemble the breathing system including the flow sensor module, breathing circuit module, bellows assembly, and exhalation valve assembly after removing the breathing system using the steps below.

Remove the Breathing System (page 12 of the *Advanced Breathing System Cleaning and Sterilization User's Reference Manual*):

1. Disconnect the bag hose from the bag hose connector.
2. Hold the Medisorb Canister by the handle and push on the release latch to unlock the canister. Tilt the canister downward to remove it off of the two support pins. For EZchange canisters, slide the canister up and out of the cradle.
3. Push the release button and gently pull the latch handle toward you to release the system.
4. Grasp the rear handle to support the breathing system. Slide the breathing system away from the workstation by pulling it toward you using the latch handle.

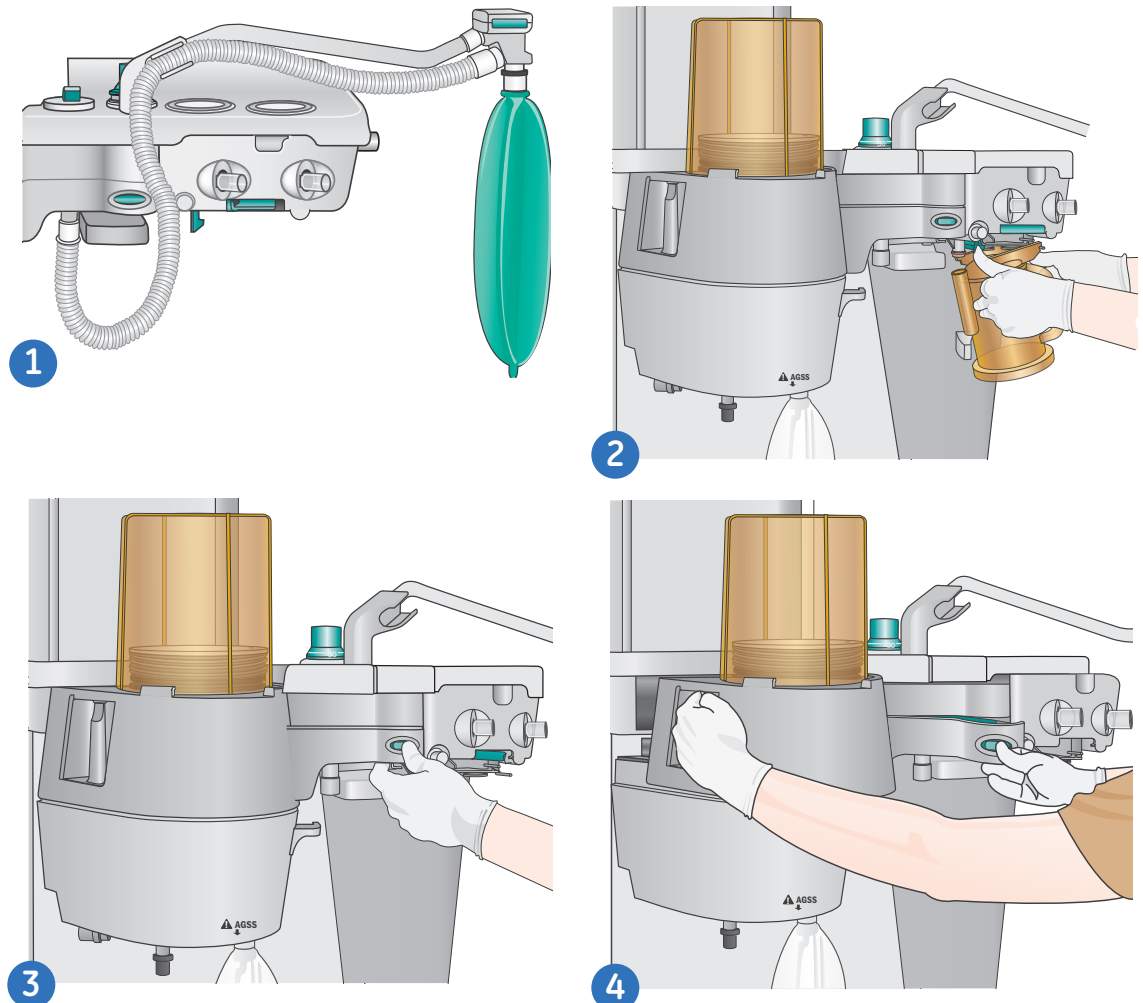

Figure 11.1 Removing the Breathing System

Replace the Breathing System

1. Align the pin openings with the guide pins.
2. Hold the rear handle and the latch handle and slide the breathing system onto the guide pins.
3. Use the grip under the latch handle to push the breathing system in fully until it latches firmly.
4. Install the absorber canister and bag hose.
5. Complete a full machine check to ensure that the breathing system is properly assembled.



Note! Please refer to the **Advanced Breathing System Cleaning and Sterilization User's Reference Manual** for more information on cleaning and sterilization. Any part labeled with 134 degree Celsius can be autoclaved.

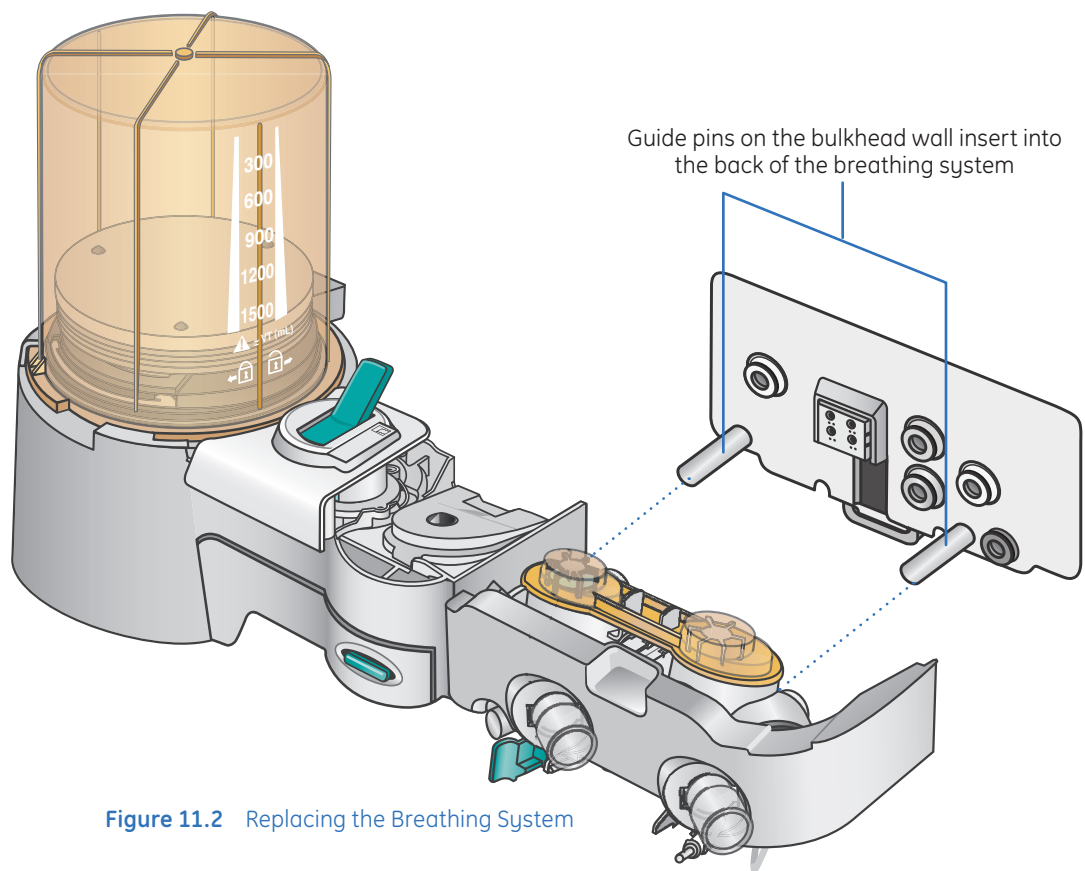

Figure 11.2 Replacing the Breathing System

Flow Sensor Module

Remove the Flow Sensor Module

1. Pull the latch to unlock the flow sensor module.
2. Pull the flow sensor module from the breathing system.

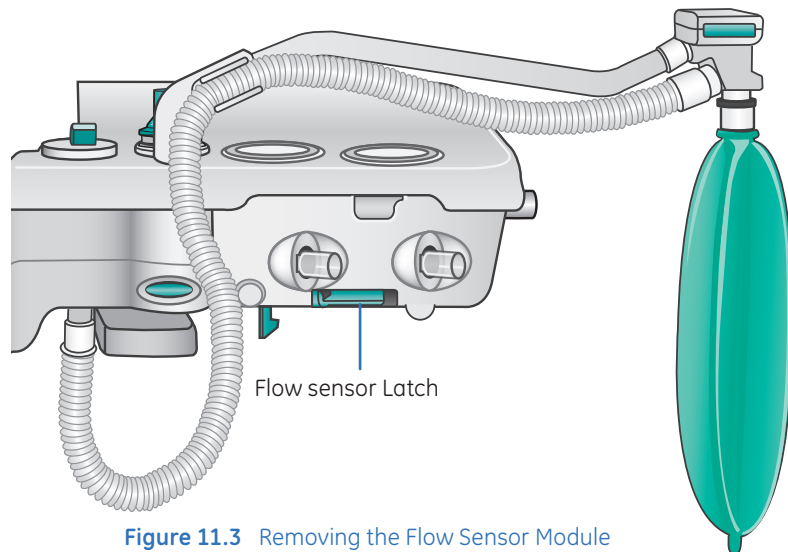

Figure 11.3 Removing the Flow Sensor Module

Remove the Flow Sensors

1. Loosen the thumb screw.
2. Pull off the flow sensor cover from the flow sensor holder.
3. Remove the flow sensor connectors from the flow sensor holder.
4. Pull the flow sensors from the flow sensor holder.
5. Plastic flow sensors cannot be autoclaved and should last a minimum of six months. Metal flow sensors can be autoclaved and should last a minimum of one year. Replace flow sensors as necessary.

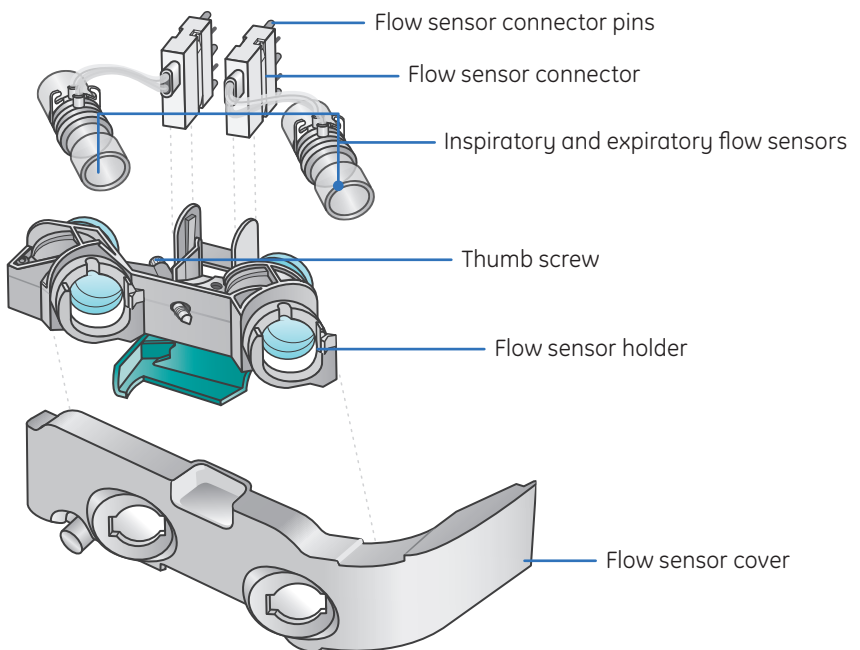

Figure 11.4 Flow Sensor Components

Replace the Flow sensors

1. Insert the flow sensors into the flow sensor holder with the black-lined tube facing toward the flow sensor holder.
2. Attach the flow sensor connectors to the flow sensor holder.
3. Attach the cover to the flow sensor holder.
4. Tighten the thumbscrew to fasten the cover.

Replace the Flow Sensor Module

1. Attach the flow sensor module to the breathing system. Be sure to align the flow sensor tubes with the grooves in the flow sensor holder.
2. Push the latch closed to lock the flow sensor module into place on the breathing system.

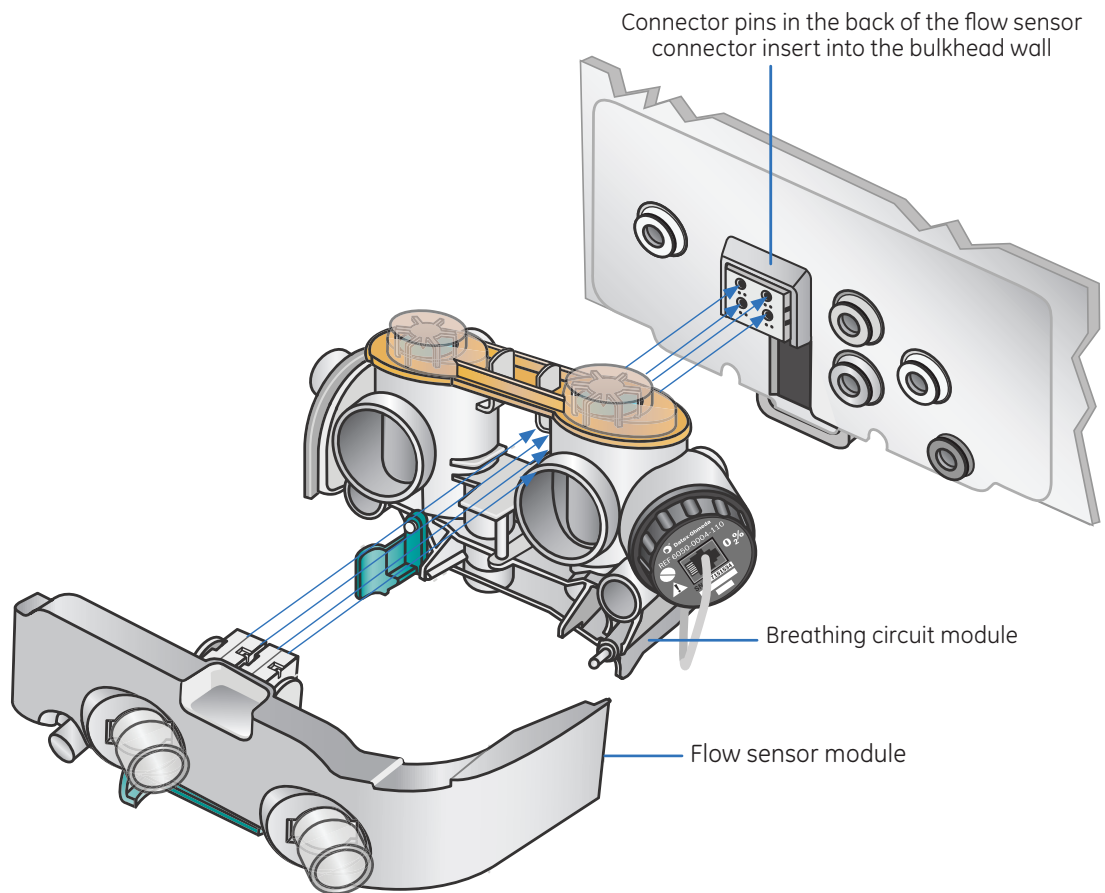

Figure 11.5 Replacing the Flow Sensors

Breathing Circuit Module

Remove the Breathing Circuit Module

1. If applicable - Remove the O₂ cell cable from the cell. Unscrew the O₂ cell counterclockwise and remove it. Remove the O₂ cell cable by pressing on the connector button while pulling the connector out.
2. Rotate the breathing circuit module counterclockwise. After rotating, pull the breathing circuit module apart from the bellows assembly by lifting up on the breathing circuit module.
3. On the breathing circuit module, remove the check valve lens by squeezing the latches together and pulling up on the lens. Lift out the check valve assemblies.

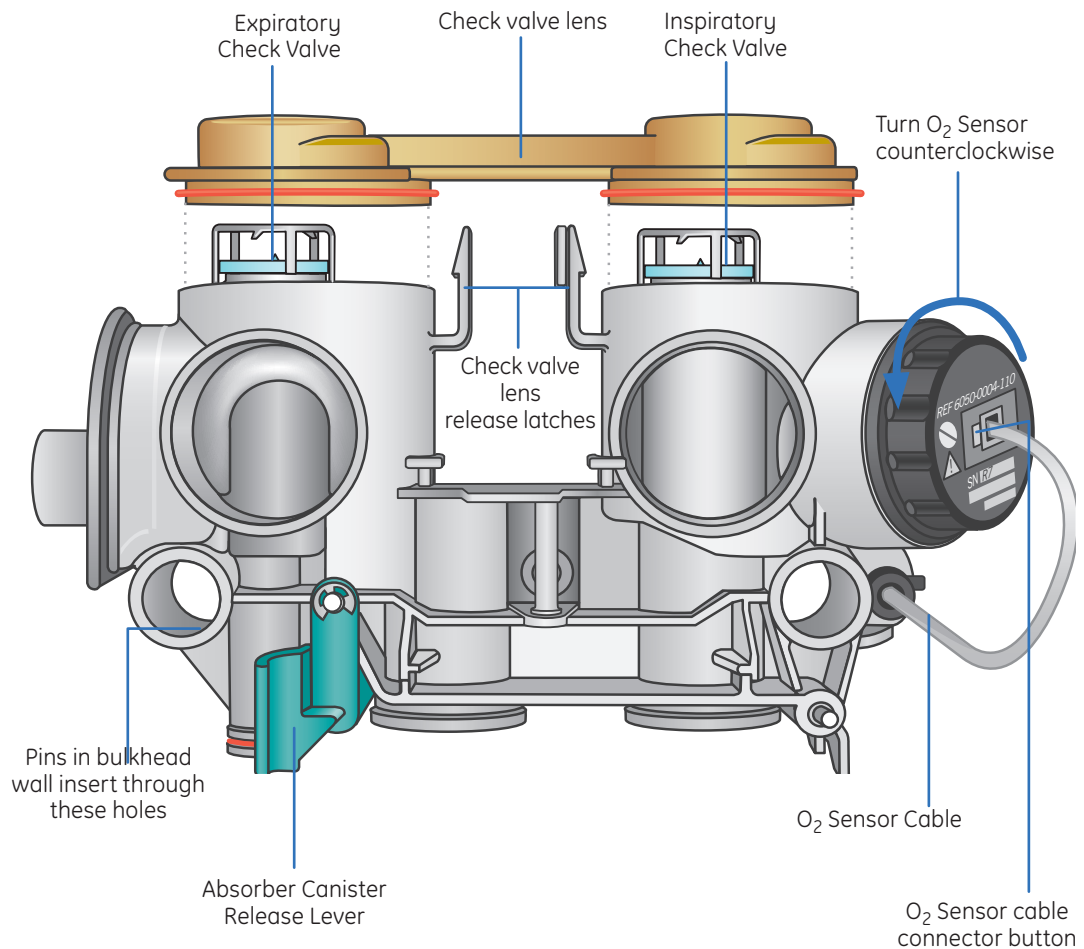
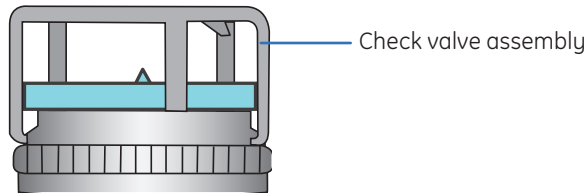

Figure 11.6 Removing the Breathing Circuit Module

Replace the Breathing Circuit Module

1. On the breathing circuit module, replace the check valve assemblies. Push the check valve circuit lens down onto the latches to lock the lens in place.



2. Insert the breathing circuit module into the bellows assembly aligned as shown.
3. Rotate the breathing circuit module clockwise at the point shown by the dotted line to attach it to the bellows assembly.
4. If applicable – Replace the cell by screwing it in clockwise. Reconnect the O₂ cell cable.

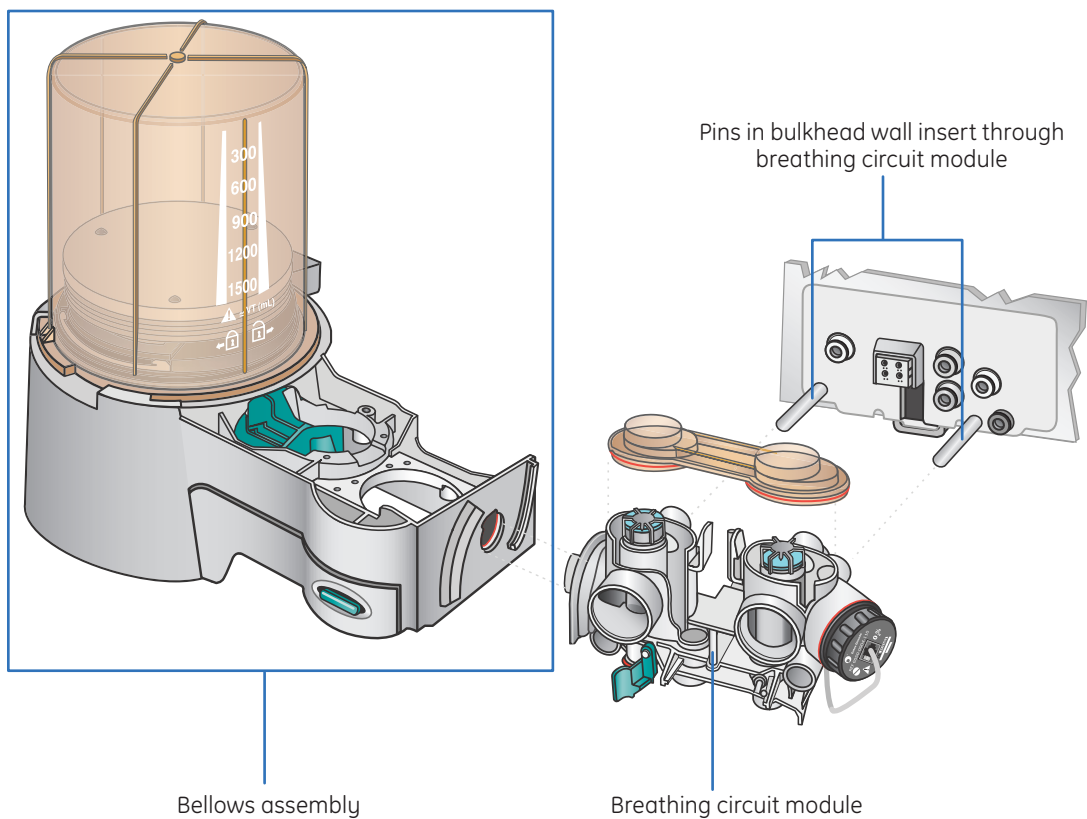

Figure 11.7 Replacing the Breathing Circuit

Bellows Assembly

Disassemble the Bellows Assembly

1. Turn the bellows housing counterclockwise and lift.
2. Remove the bottom edge of the bellows and lift.
3. Push the two tabs toward the center and remove the rim.
4. Remove the pressure relief valve.
5. Push the latch toward the center and remove the locking tabs.
6. Remove the seal.

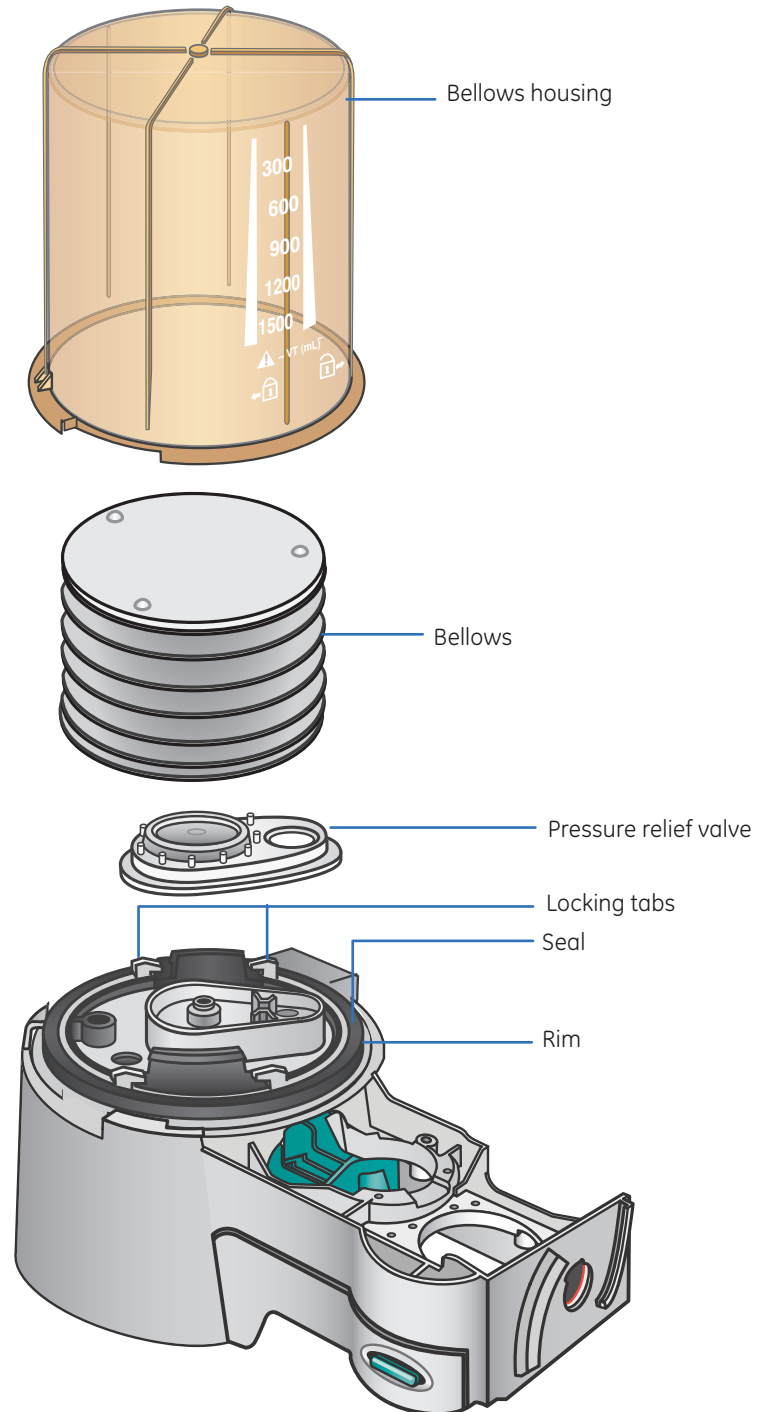

Figure 11.8 Bellows Assembly

Assemble the Bellows Assembly

1. Install the seal and verify the arrow and the groove on the seal point up.
2. Push the latch toward the center and attach the locking tabs.
3. Install the pressure relief valve.
4. Push the two tabs toward the center and install the rim. A click should be heard when the rim is installed.
5. Attach the bottom edge of the bellows to the rim. Verify that the bottom ring of the bellows is fitted over the rim.
6. Lower the bellows housing and turn it clockwise to lock. Verify housing is secure.

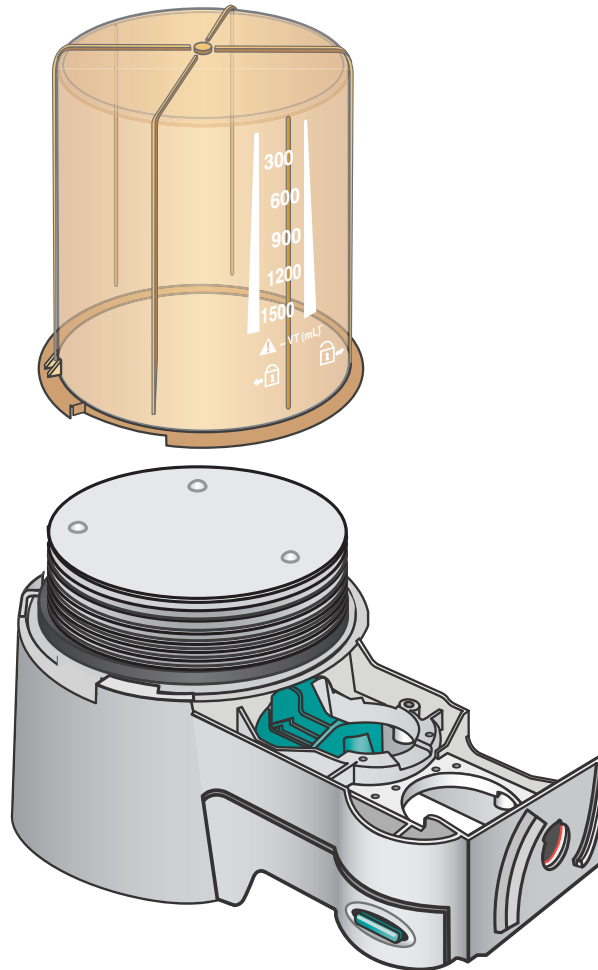

Figure 11.9 Bellows Assembly and Canister

Bellows assembly test (Verify the bellows is assembled correctly):

Your class instructor will demonstrate the proper method for testing the Bellows Assembly. You may also refer to the *Advanced Breathing System Cleaning and Sterilization User's Reference Manual, page 21*.

Exhalation Valve

Remove the Exhalation Valve Assembly

1. With the breathing system removed, the exhalation valve assembly can be removed.
2. Loosen the thumbscrews and lift the assembly off.

Replace the Exhalation Valve Assembly

1. Replace the exhalation valve assembly and tighten the thumbscrews.

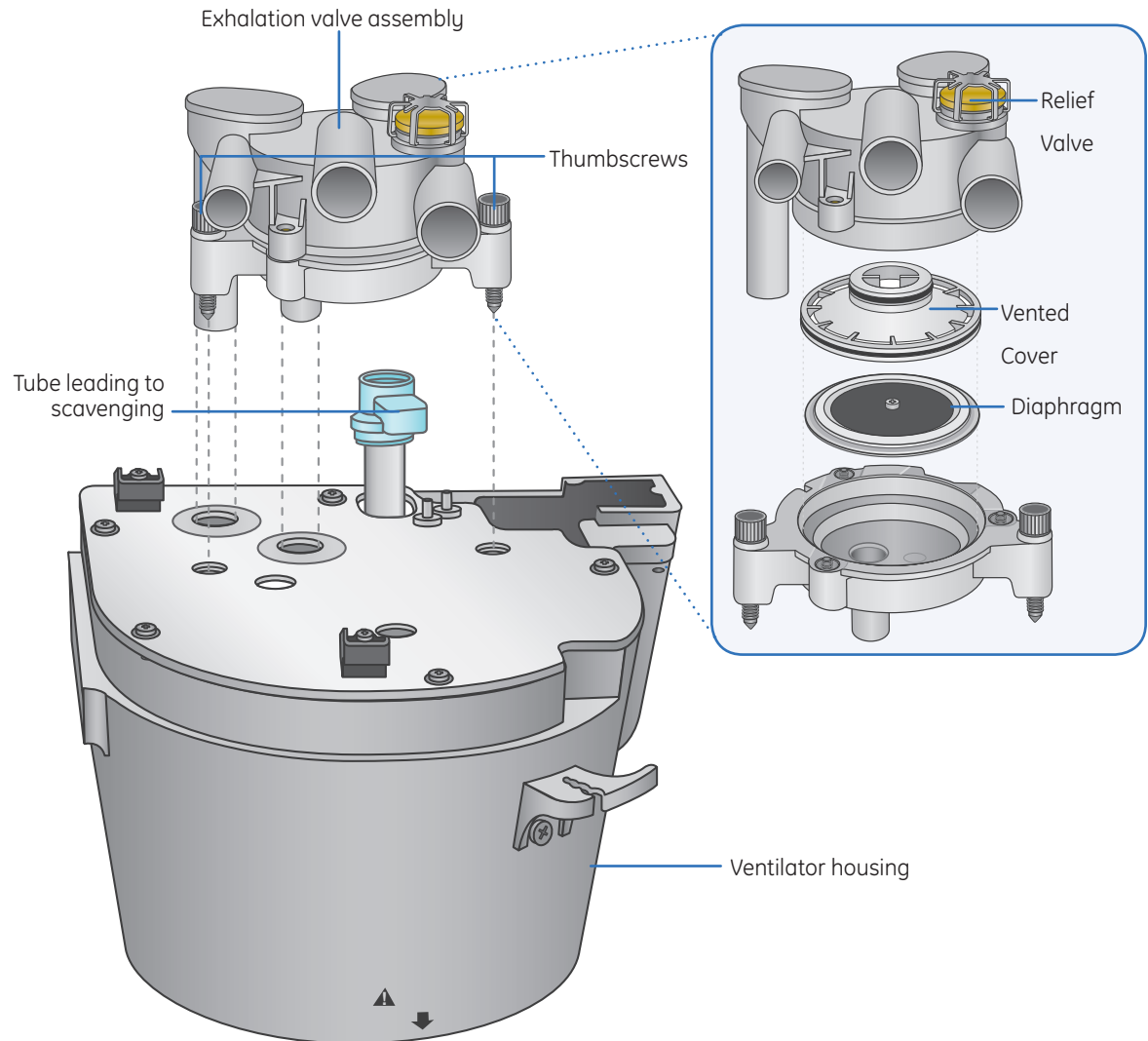

Figure 11.10 Exhalation Valve

12 Resources

Avance User Operational Maintenance Schedule

Activity	Frequency
Full Anesthesia System Checkout	Daily: URM sect. 4-2
Flow Sensor Calibration	Daily: URM sect. 4-2
Flow Sensor Replacement	PRN: Typically six months URM sect. 9-4
Inspect and Clean Fan Filters	Monthly and PRN: URM sect. 9-4
Suction Overflow Trap	PRN: URM sect. 9-4
Empty Condenser Reservoir	Daily and PRN: URM sect. 9-4
Change Absorbent Canister	When Inspired CO₂ is observed: (level dependent on hospital policy) URM sect. 8-5
GE / Datex-Ohmeda Gas Module	
Gas Calibration	Every six months or every two months with heavy usage: URM sect. 9-4
Black D-Fend	Replace the D-Fend water trap at least every two months or when a "Sample line blocked" or "Replace D-Fend" alarm persists. (Avance URM sect. 7-9)

Avance Anesthesia Supplies and Accessories

Part Number	Description
Flow Sensor Supplies	
**1503-3858-000	(Flow sensors (off-set)
1407-3003-000	Flow sensor module (reusable)
Breathing System Supplies	
**8003138	Medisorb multi absorber, disposable 6/box (each lasts about 8 continuous hours)
8004515	Reusable, hytel patient tubing 36" (for use on bag arm)
8004459	ABS Bag arm connector elbow (for use on bag arm)
8004454	Manual vent bag arm hose and elbow, disposable
2900-0001-000	Stopper test plug – used for low-pressure leak test
1503-3857-000	O ₂ sensor plug
8004460	3L Scavenging Bag, Reusable
1407-3200-000	Reusable CO ₂ Canister with handle
1407-3201-000	Disposable CO ₂ Foam Filter (pack of 40)
Vaporizer Supplies	
1100-3025-000	Easy Fill Bottle Adapter, Isoflurane
1100-3026-000	Easy Fill Bottle Adapter, Halothane
1100-3027-000	Easy Fill Bottle Adapter, Enflurane
1100-3028-000	Easy Fill Bottle Adapter, Sevoflurane
Supplies Associated with Datex-Ohmeda	
**876446	D-Fend Water Trap, black 10/box
8004463	Gas Scavenger line-17cm with colter fitting
73319	Sample lines, 10/pkg
755571-HEL	Calibration Gas
M1006864	Calibration Gas Regulator

**These items are supplies that will be used regularly and should be stocked. The others are for reserve or back-up and are optional.

Contact number for supplies issues, questions and orders will be supplied by the clinical trainer in the area below:

Avance Quick Guide

<p>To Start Gas Flows from the Stand-By Screen:</p>	<ul style="list-style-type: none"> • Press the Start/End Case key • Press the green ComWheel to confirm • or • Press any of the quick keys twice <p>Note: This starts the gas flows at 100% FiO₂.</p>
<p>To Change to Individual Gas Flow Settings: Note: Menu item may be blocked if set for the facility by the Super User</p>	<ul style="list-style-type: none"> • Press the Main Menu key • Scroll to Screen Setup, press the green ComWheel • Scroll to Fresh Gas Control, press the green ComWheel • Scroll to Flow to select Individual Flows or scroll to O₂% to select O₂% and Total Flow, press the green ComWheel • Press Normal Screen
<p>To Add a Digital Airway Pressure Manometer to Screen:</p>	<ul style="list-style-type: none"> • Press the Main Menu key • Scroll to Screen Setup, press the green ComWheel • Scroll to Split Screen, press the green ComWheel • Scroll to Paw, press the green ComWheel • Press Normal Screen <p>Note: You will notice the Pawmanometer above the electronic flowmeters.</p>
<p>To Preset Ventilator Settings before a Case:</p>	<ul style="list-style-type: none"> • Press the Start/End Case key • Press the Vent Setup key, scroll to the desired mode or Adjust Settings, press the green ComWheel • A second window opens to allow you to adjust settings • Scroll to the desired parameter(s) to adjust, press the green ComWheel, adjust the setting(s), press the green ComWheel • Scroll to Confirm, press the green ComWheel when the setting adjustments are complete
<p>To Preset Alarm Settings before a Case:</p>	<ul style="list-style-type: none"> • Press the Start/End Case key • Press the Alarm Setup key • Select Adjust Settings, press the green ComWheel • Scroll to the desired alarm(s), press the green ComWheel • Scroll to the desired value, press the green ComWheel • Scroll to Back, press the green ComWheel • Scroll to Previous Menu or Start Case, press the green ComWheel when complete
<p>To Turn the MV/TV Alarms off:</p>	<ul style="list-style-type: none"> • Press the MV/TV Alarms key on the upper left of the ventilator display to toggle the MV/TV alarms on and off. • or • Press the Alarm Setup key • Scroll to MV/TV Alarms, press the green ComWheel • Scroll to Off, press the green ComWheel • Push the Normal Screen key <p>Note: MV/TV Alarms Off will be displayed in the upper right hand corner next to the clock and will remain off until the Bag/Vent switch is set to Vent. Remember Volume Apnea cannot be permanently disabled while in Vent Mode.</p>

Quick Guide *Continued*

To Change from N2O to Air during case:	<ul style="list-style-type: none"> • Press Gas Setup key • Scroll to Air, press the green ComWheel • Press Normal Screen
To Turn CO ₂ Alarms off:	<ul style="list-style-type: none"> • Press the Alarm Setup key • Scroll to CO₂ Alarms, press the green ComWheel • Scroll to Off, press the green ComWheel • Push the Normal Screen key <p>Note: CO₂ alarms will be displayed in the upper right hand corner next to the clock. CO₂ alarms remain silenced while in bag mode and will reactivate when in vent mode. CO₂ Alarms can be turned off from the Start Case menu.</p>
To Change Data Source from Vent to Patient:	<ul style="list-style-type: none"> • Press Spirometry key • Scroll to Spiro Setup, press green ComWheel • Scroll to Data Source, press green ComWheel • Scroll to Patient, press green ComWheel • Follow the above steps to change back to Vent • Vent is used when getting the tidal volume information from the flow sensors. • Patient is used when getting the tidal volume information from the spirometry adapter. • Patient can also be used to get the respiratory rate displayed during MAC cases on the vent screen. <p>Note: If Patient is selected and no spirometry adapter is used the vent screen will ONLY show ETCO₂ waveforms. The ventilator is running, but the Data Source needs to be changed back to Vent.</p>
To Turn off the Volume Apnea alarm during MAC cases:	<ul style="list-style-type: none"> • Press the Alarms Setup key • Scroll to Volume Apnea and press the green ComWheel • Scroll to OFF and press the green ComWheel in to confirm <p>Note: Volume Apnea alarms can be turned off from the Start Case menu.</p>
To Change Vent Modes:	<ul style="list-style-type: none"> • Press Vent Setup key • Scroll to desired mode and press the green ComWheel • A second window opens to allow you to adjust settings • Scroll to desired parameter(s) to adjust and press the green ComWheel • Adjust the setting(s) and press the green ComWheel • Scroll to Confirm and press the green ComWheel when setting adjustments are complete <p>Note: The vent mode will not be changed until you have confirmed your settings.</p>
To Change from Adult to Pedi when using the Spirometry Adapter:	<ul style="list-style-type: none"> • Press Spirometry key • Scroll to Spiro Setup, press the green ComWheel • Scroll to Patient and Sensor Type, press the green ComWheel • Scroll to Pedi, press the green ComWheel • Follow the above steps to change back to Adult
To Turn off Gas Flows and Silence alarms at the End of Case:	<ul style="list-style-type: none"> • Press the Start/End Case key • Press the green ComWheel to End Case Now

Avance Troubleshooting Guide

Taken from: *pages 7-4 through 7-11 of the User's Reference Manual.*

Message	Cause	Action/Concern
Apnea >120s	Apnea time exceeds one hundred twenty seconds.	Check for leaks or blockages in the breathing circuit. Ensure the Bag/Vent switch is in the Vent position. Check the patient.
Check D-Fend	Water trap not attached.	Check that the water trap is properly attached to the airway module.
Check flow sensors	System has detected an improper flow pattern in breathing circuit.	Ensure the internal flow sensors are connected correctly.
Circuit leak	Vent TV _{exp} < half of vent TV _{insp} for at least thirty seconds.	Check for leaks in the patient circuit. Calibrate flow sensors. If the problem persists, replace flow sensors.
FiCO ₂ high. Absorbent OK?	FiCO ₂ > alarm limit	Check if absorbent needs to be changed. Check the patient.
No exp flow sensor; No insp flow sensor	Electrical signals show the flow sensor is not connected.	Connect the flow sensors. Make sure the flow sensor module is in all the way. Replace flow sensors, if necessary.
No fresh gas flow!	Possible patient detected while system is in standby.	Disconnect the patient or start a case.
No fresh gas flow?	Possible fresh gas flow occlusion or loss of gas pressure.	Switch to circle circuit or bag the patient. Check pipeline supply connection.
PEEP high. Blockage?	Paw ≥ sustained limit for fifteen seconds.	Check for blockages in the patient circuit. Check scavenging.
Plug in power cable. On battery.	The mains supply is not connected or has failed and the system is using battery power.	Ventilate manually to save power. Make sure the power cable is plugged in and system circuit breaker is on.
Replace D-Fend	Build up in airway module sample line.	Replace D-Fend.
Reverse exp flow. Check valves OK?	Flow toward the patient seen in the expiratory flow sensor during inspiration for six breaths in a row.	Check flow sensor condition. Replace the expiratory check valve between cases. Zero flow transducers between cases.
Reverse insp flow. Check valves OK?	Flow away from the patient seen in the inspiratory sensor during expiration for six breaths in a row.	Check the flow sensor condition. Replace the expiratory check valve between cases. Zero flow transducers between cases.
Turn power Off and On for self tests	System has been operating for longer than twelve hours without a power up self-test.	Turn power off and back on between cases to perform a self-test.
Replace insp flow sensor	EEPROM calibration data read failure.	Replace the inspiratory flow sensor.
TV not achieved	Measured tidal volume is < set tidal volume.	Check for leaks in the patient circuit. Check for leaks in the breathing system.
Unable to drive bellows	Bellows is collapsed.	Check the drive gas. Increase fresh gas flow (or push O ₂ flush button) to fill bellows.
Vol vent only. No PEEP or PSV.	Manifold pressure error. Pressure Control unavailable. Medium priority alarm when Bag/Vent switch is in Vent and running PCV, PSVPro, SIMV-PC, CPAP/PSV, or PCV-VG mode.	Use volume control ventilation mode. Shut down system as soon as possible. Contact a Datex-Ohmeda trained service representative.

13 Clinical Training Documents

Clinical Training Checklist

The following topics will be presented.

The purpose of this document is to verify that the following items are covered during your Avance training. You should be prepared to operate the Avance by the end of the training time. If you still believe that you are not prepared, please talk to your trainer or your manager. Please refer to the Avance User's Reference Manuals for complete instructions on the operation of the Avance Anesthesia System.

Introduction to the Avance

Place a checkmark next to topics discussed.

- Overview
 - System and display components
 - System power and battery back-up power
 - O₂ information sources
 - O₂ flush
 - Alternate O₂ control
 - Electronic Gas Delivery System
 - Scavenging

- Screen Navigation
 - Using Menus, the ComWheel and Quick Keys
 - Main Menu
 - Select Page

- Vaporization
 - Filling the vaporizers
 - Remove and replace the vaporizers

- Advanced Breathing System
 - Bag/Vent switch
 - APL valve
 - Changing CO₂ absorber canister
 - Draining condenser
 - Zeroing flow sensors and preventing moisture buildup

Continued

Clinical Training Checklist *Continued*

- Operation
 - Start and End Case procedures
 - Minimum Alveolar Concentration
 - Changing vent modes and settings
 - Gas Setup
 - Trends
 - Cardiac Bypass
 - Alarm management

- Ventilation Modes
 - Volume Control Ventilation
 - Pressure Control Ventilation
 - SIMV/PSV
 - PSV Pro
 - SIMV-PC
 - PCV-VG
 - CPAP/PSV

- Spirometry
 - Setting loop type and scaling
 - Spirometry setup
 - Storing and erasing loops

- Procedures
 - Pause Gas Flow
 - Vital Capacity
 - Cycling

- System Checkout
 - Checkout menu
 - Complete system checkout

- Maintenance and troubleshooting
- Hands-on exercises
- Clinical skills checklist - see attached
- Training quiz
- Evaluation

Avance Carestation Clinical Skills Checklist

To help ensure safe operation of the Avance Carestation, you must be able to perform the following functions:

Place a checkmark next to topics completed.

- Calibrate (remove and replace) the flow sensor module.
- Remove and replace the CO₂ absorber canister.
- Bypass the machine check out and start an emergency case.
- Perform a complete electronic machine check.
 - System
 - Circuit
 - Low-pressure leak
- Start a case from the machine in Standby.
- Change gases between air and nitrous oxide.
- Fill and change a vaporizer.
- Adjust agent concentration.
- Change ventilation modes.
- Change ventilation settings.
- Turn Cardiac Bypass on and off.
- Set and adjust alarm limits and alarm volume.
- End a case to stop gas flow and end the patient alarms.
- Remove and replace the D-fend and attached gas sample line.
- Manually activate the alternate O₂ source and regulate O₂ flow (the procedure used during an emergency or failure).
- Turn suction on to maximum, and then change to regulated suction and adjust suction pressure.
- Utilize Pause Gas Flow, Vital Capacity and Cycling from the Procedures menu.
- Save and view a loop from the Spirometry menu.
- I have been trained and am able to complete all of the above named skills.**

Print Name: _____ Date: _____

Signature: _____

Clinical Training Quiz

After completion of the test, compare your answers to the answer key. Ask the instructor to explain any answers you do not understand.

Circle the correct answer.

1. The average capacity of a fully charged battery is 30-45 minutes. **True False**
2. Pipeline and tank pressures are displayed on the screen between cases. **True False**
3. The system checkout can be bypassed at any time. **True False**
4. A complete system checkout should be performed at least once every _____ hours.
 - A. 12
 - B. 24
 - C. 36
 - D. As needed
5. When starting a case, the Avance delivers O₂ at _____ to pre-oxygenate the patient.
 - A. 50%
 - B. 100%
 - C. 80%
 - D. User defined%
6. End-case procedures automatically shut off all fresh gas flow. **True False**
7. Either Air or N₂O can only be selected through the Start Case menu. **True False**
8. Alternate O₂ can be manually selected only if the anesthesia display fails. **True False**
9. The bag support arm carries patient gas. **True False**
10. The Advanced Breathing System (ABS) is a small, compact system with a 2.7-liter circuit volume. **True False**
11. Fresh gases are delivered just behind the inspiratory check valve and immediately delivered to the patient with each breath. **True False**
12. The 7900 smart vent cannot compensate for fresh gas flow changes, only small system leaks. **True False**
13. Pressure Control Ventilation (PCV) utilizes a decelerating inspiratory flow pattern and a square pressure waveform. **True False**
14. A case must be started to prevent a No fresh gas flow alarm during MAC cases with ETCO₂ monitoring. **True False**

Clinical Training Quiz *Continued*

15. An active alarm can be silenced for _____ seconds.
- A. 30
 - B. 60
 - C. 90
 - D. 120
16. An anticipated alarm can be pre-silenced for _____ seconds.
- A. 30
 - B. 60
 - C. 90
 - D. 120
17. High priority warning alarms display white text with a red background. **True False**
18. When the scavenger system is properly functioning, the reservoir bag will be completely deflated. **True False**
19. At the end of the machine checkout, the APL valve (pop off) should be placed back to minimum. **True False**
20. The gas sample line should not be attached to the D-fend H₂O trap prior to turning the machine on. **True False**
21. The alternate O₂ will be automatically activated in the event of:
- A. Total power failure.
 - B. Electronic mixer failure
 - C. Screen failure
 - D. All of the above
22. SIMV mode can be chosen to deliver volume or pressure breaths. **True False**
23. PSVPro defaults to which ventilation mode as an apnea backup?
- A. PCV
 - B. SIMV-PC
 - C. SIMV/PSV
 - D. PCV-VG
24. PSVPro is a mode of ventilation that works well with paralyzed patients. **True False**
25. The ventilator does not have to be on to provide Pressure Support Ventilation.
True False
26. Spirometry can display pressure-volume, flow-volume, and pressure-flow loops.
True False

Clinical Training Quiz *Continued*

27. Flow sensors measure airway flow, calculate pressure changes, and display both inspiratory and expiratory volumes on the ventilator screen. **True False**
28. Flow sensors should be calibrated on a weekly basis. **True False**
29. The D-fend water trap should be replaced at least every _____ months.
- A. 1
 - B. 2
 - C. 3
 - D. 4

Clinical Training Quiz Answer Sheet

1. The capacity of a fully charged battery is 30-45 minutes. **True**
2. Pipeline and tank pressures are displayed on the screen between cases. **True**
3. The system checkout can be bypassed at any time. **True**
4. A complete system checkout should be performed at least once every 24 hours. **B.**
5. When starting a case, the Avance delivers O₂ at a user defined % to pre-oxygenate the patient. **D.**
6. End-case procedures automatically shut off all fresh gas flow. **True**
7. Either Air or N₂O can only be selected through the Start Case menu. Can also be selected by using the Gray Gas Setup key. **False**
8. Alternate O₂ can be manually selected only if the anesthesia display fails. Happens automatically in the event of software, screen, and total failures. **False**
9. The bag support arm carries patient gas. Does **NOT** carry any gas. **False**
10. The Advanced Breathing System (ABS) is a small, compact system with a 2.7-liter circuit volume. With the moisture condenser the absorber volume is 3.4-liter. **True**
11. Fresh gases are delivered just behind the inspiratory check valve and immediately delivered to the patient with each breath. **True**
12. The 7900 smart vent can not compensate for fresh gas flow changes, only small system leaks. *The vent CAN compensate for fresh gas flow changes AND small system leaks.* **False**
13. Pressure Control Ventilation (PCV) utilizes a decelerating inspiratory flow pattern and a square pressure waveform. **True**
14. A case must be started to prevent a No fresh gas flow alarm during MAC cases with ETCO₂ monitoring. **True**
15. An active alarm can be silenced for **120** seconds. **D.**
16. An inactive alarm can be pre-silenced for **90** seconds. **C.**
17. High priority warning alarms display white text with a red background. **True**
18. When the scavenger system is properly functioning the reservoir bag will be completely deflated. Simulate breathing. **False**

19. At the end of machine checkout, put the APL valve (pop off) back to minimum. **True**
20. The gas sample line does not need(s) to be attached to the D-fend prior to turning the machine on. **False**
21. The alternate O₂ will automatically be activated in the event of: **D. All of the above**
- A. Total power failure. (*When the battery and power fail.*)
 - B. Electronic Gas module failure.
 - C. Screen failure.
 - D. All of the above
22. SIMV mode can be chosen to deliver volume or pressure breaths. **True**
23. PSVPro defaults to which ventilation mode as an apnea backup? **B. SIMV-PC**
24. PSVPro is a mode of ventilation that works well with paralyzed patients. Spontaneously breathing. **False**
25. The ventilator does not have to be on to provide Pressure Support Ventilation. **False**
26. Spirometry can display pressure-volume, flow-volume, and pressure-flow loops. **True**
27. Flow sensors measure airway flow, calculate pressure changes, and display both inspiratory and expiratory volumes on the ventilator screen. **True**
28. Flow sensors should be calibrated on a weekly basis. Daily **False**
29. The D-fend water trap should be replaced at least every 2 months. **B. 2**

14 Non-Clinical Training Documents

Avance Non-Clinical Training Checklist

The following topics will be presented.

The purpose of this document is to verify that the following items are covered during your Avance training. You should be prepared to operate the Avance by the end of the training time. If you still believe that you are not prepared, please talk to your trainer or your manager. Please refer to the Avance User's Reference Manuals for complete instructions on the operation of the Avance Anesthesia System.

Introduction to the Avance

Place a checkmark next to topics discussed.

- Overview
 - System and display components
 - System power and battery back-up power
 - O₂ information sources
 - O₂ flush
 - Alternate O₂ control
 - Electronic Gas Delivery System
 - Scavenging

- Screen Navigation
 - Using Menus, the ComWheel and Quick Keys

- Vaporization
 - Filling and changing the vaporizers

- Advanced Breathing System
 - Bag/Vent switch
 - APL valve
 - Changing CO₂ absorber canister
 - Draining condenser
 - Zeroing flow sensors and preventing moisture buildup

- Operation
 - Start and End Case procedures

Continued

Non-Clinical Training Checklist *Continued*

- System Checkout
 - Checkout menu
 - Complete system checkout
- Maintenance and troubleshooting
- Hands-on exercises
- Non-Clinical skills checklist - see attached
- Training quiz
- Evaluation

Avance Carestation Non-Clinical Skills Checklist

To help ensure safe operation of the Avance Carestation, you must be able to perform the following functions:

Place a checkmark next to topics completed.

- Calibrate (remove and replace) the flow sensor module.
- Remove and replace the CO₂ absorber canister.
- Adjust the scavenging
- Bypass the machine check out and start an emergency case.
- Perform a complete electronic machine check.
 - System
 - Circuit
 - Low-pressure leak
- Start a case from the machine in Standby.
- Change gases between air and nitrous oxide.
- Fill and change a vaporizer.
- End a case to stop gas flow and end the patient alarms.
- Remove and replace the D-fend and attached gas sample line.
- Manually activate the alternate O₂ source and regulate O₂ flow (the procedure used during an emergency or failure).
- Turn suction on to maximum, and then change to regulated suction and adjust suction pressure.
- I have been trained and am able to complete all of the above named skills.

Print Name: _____ Date: _____

Signature: _____

Non-Clinical Training Quiz

After completion of the test, compare your answers to the answer key. Ask the instructor to explain any answers you do not understand.

Circle the correct answer

1. If the Master On/Off switch on the back of the machine is off, the vital signs monitor will work. **True False**
2. The average capacity of a fully charged battery is 30-45 minutes. **True False**
3. The filters on the machine and gas module are inspected and cleaned monthly and PRN. **True False**
4. Pipeline and tank pressures are displayed on the screen between cases. **True False**
5. The CO₂ absorbent canister can be installed correctly in either direction. **True False**
6. The automated part of the system checkout verifies scavenging connection and flow. **True False**
7. A complete system checkout should be performed at least once every _____ hours.
 - A. 12
 - B. 24
 - C. 36
 - D. As needed
8. When starting a case, the Avance delivers O₂ at _____ to pre-oxygenate the patient.
 - A. 50%
 - B. 100%
 - C. 80%
 - D. User defined%
9. End-case procedures automatically shut off all fresh gas flow. **True False**
10. Alternate O₂ must be manually enabled if the anesthesia display fails. **True False**
11. The bag support arm carries patient gas. **True False**
12. The Advanced Breathing System (ABS) is a small, compact system with a 2.7-liter circuit volume. **True False**
13. A case must be started to correct a *No fresh gas flow alarm*. **True False**

Non - Clinical Training Quiz *Continued*

14. At the end of the machine checkout, the APL valve (pop off) should be placed back to minimum. **True False**
15. The gas sample line should not be attached to the D-fend H₂O trap prior to turning the machine on. **True False**
16. An active alarm can be silenced for _____ seconds.
- A. 30
 - B. 60
 - C. 90
 - D. 120
17. Medium priority alarms are in red and high priority alarms are in yellow. **True False**
18. Flow sensors should be calibrated on a weekly basis. **True False**
19. D-fend water trap should be replaced at least every _____ months.
- A. 1
 - B. 2
 - C. 3
 - D. 4

Non-Clinical Training Quiz Answer Sheet

1. If the Master On/Off switch on the back of the machine is off, the vital signs monitor **will not** work. **False**
2. The average capacity of a fully charged battery is 30-45 minutes. **True**
3. The filters on the machine and gas module are inspected and cleaned monthly and as necessary. **True**
4. Pipeline and tank pressures are displayed on the screen between cases. **True**
5. The CO₂ absorbent canister can only be installed in **one** direction. **Handle faces forward only. False**
6. The automated part of the system checkout **does not verify** scavenging connection and flow. **False**
7. A complete system checkout should be performed at least once every **24** hours. **B**
8. When starting a case, the Avance delivers O₂ at **a user defined %** to pre-oxygenate the patient. **D**
9. End-case procedures automatically shut off all fresh gas flow. **True**
10. Alternate O₂ is **automatically** enabled if the anesthesia display fails. **And can be manually activated at any time. False**
11. The bag support arm **does not** carry patient gas. **False**
12. The Advanced Breathing System (ABS) is a small, compact system with a 2.7-liter circuit volume. **With condenser the breathing system will be 3.4 liters. True**
13. A case must be started and ended to correct a *No fresh gas flow alarm*. **True**
14. At the end of the machine checkout, the APL valve (pop off) should be placed back to minimum. **True**
15. The gas sample line should **not** be attached to the D-fend H₂O trap prior to turning the machine on. **False**
16. An active alarm can be silenced for **120** seconds. **Alarms can be pre-silenced for 90 seconds. D**
17. Alert alarms are in **yellow** and warning alarms are in **red**. **False**
18. Flow sensors should be calibrated on a **daily** basis. **False**
19. D-fend water trap should be replaced at least every **2** months. **B**



Course Evaluation

Avance Carestation

Course Name: _____ Date: _____

Location: _____ Instructor: _____

Please complete the following survey. The information you provide will help us to improve the course for future learners.

Rate the training by circling the appropriate number

Course Content	4 = Strongly agree	3 = Agree	2 = Disagree	1 = Strongly disagree	
The content covered the topics adequately and clearly.	4	3	2	1	NA
The activities/exercises helped me learn the content presented.	4	3	2	1	NA
The participant guide was easy to follow.	4	3	2	1	NA
The knowledge checks and/or assessments in this course were effective in helping me validate my existing and acquired knowledge.	4	3	2	1	NA
Comments:					

Instructor Delivery	4 = Strongly agree	3 = Agree	2 = Disagree	1 = Strongly disagree	
Instructor was prepared for the training session.	4	3	2	1	NA
Instructor was knowledgeable about the course content.	4	3	2	1	NA
Instructor effectively presented the course content.	4	3	2	1	NA
Instructor effectively responded to student questions.	4	3	2	1	NA
Comments:					

Course Experience	10 = Strongly agree	9	8	7	6	5	4	3	2	1 = Strongly disagree
Rate your overall satisfaction with the course content.	10	9	8	7	6	5	4	3	2	1
Rate your overall satisfaction with the Instructor delivery.	10	9	8	7	6	5	4	3	2	1
I would recommend this training course to a friend or colleague.	10	9	8	7	6	5	4	3	2	1
Comments:										

Would you like to be contacted in the future for further inputs on our training development, delivery, and operations processes?

No **Yes** If yes, please provide your name and email ID here: _____

© 2011 General Electric Company – All rights reserved.
GE and GE Monogram are trademarks of General Electric Company.

General Electric Company reserves the right to make changes in specifications and features shown herein, or discontinue the product described at any time without notice or obligation.

Avance, Carestation, Advanced Breathing System, ComWheel, D-fend, EZchange, Disposable Multi Absorber, Reusable Multi Absorber, PSVPro, and SmartVent are registered trademarks of Datex-Ohmeda, Inc. Other brand names or product names used in this participant guide are trademarks or registered trademarks of their respective holders.

GE Medical Systems Information Technology, a General Electric company, doing business as GE Healthcare.

Notice: The materials contained in this document are intended for educational purposes only. This document does not establish specifications, operating procedures or maintenance methods for any of the products referenced. Always refer to the official written materials (labeling) provided with the product for specifications, operating procedures and maintenance requirements.

Proprietary Training Material Property of GE Healthcare. Use of these materials is limited to agents and employees of GE Healthcare or other parties expressly licensed by GE Healthcare. Unlicensed use is strictly prohibited.

Healthcare Re-imagined

GE is dedicated to helping you transform healthcare delivery by driving critical breakthroughs in biology and technology. Our expertise in medical imaging and information technologies, medical diagnostics, patient monitoring systems, drug discovery, and biopharmaceutical manufacturing technologies is enabling healthcare professionals around the world to discover new ways to predict, diagnose and treat disease earlier. We call this model of care “Early Health.” The goal: to help clinicians detect disease earlier, access more information and intervene earlier with more targeted treatments, so they can help their patients live their lives to the fullest. Re-think, Re-discover, Re-invent, Re-imagine.

GE Healthcare
3030 Ohmeda Drive
PO BOX 7550
Madison, WI 53707-7550
USA

www.gehealthcare.com



imagination at work