



GE Medical Systems

Technical Publication

Direction 5101336GDO
Revision 1.1

Discovery ST Conformance Statement
for DICOM (ID/Net v3.0)

Copyright © by GE Medical Systems, 2002



Page Left Intentionally Blank

LEGAL NOTES

TRADEMARKS

All products and their name brands are trademarks of their respective holders.

OMISSIONS & ERRORS

Customers, please contact your GE Sales or Service representatives.

GE personnel, please use the GEMS CQA Process to report all omissions, errors, and defects in this publication.

Copyrights

All Material Copyrighted(c) 2001 by the General Electric Company, All rights reserved.

IMPORTANT PRECAUTIONS

WARNING

- This Service Manual is available in English only.
- If a customer's service provider requires a language other than English, it is the customer's responsibility to provide translation services.
- Do not attempt to service the equipment unless this service manual has been consulted and is understood.
- Failure to heed this Warning may result in injury to the service provider, operator or patient from electric shock, mechanical or other hazards.

AVERTISSEMENT

- Ce Manuel de maintenance n'est disponible qu'en anglais.
- Si le technicien du client a besoin de ce manuel dans une autre langue que l'anglais, c'est au client qu'il incombe de le faire traduire.
- Ne pas tenter d'intervention sur les équipements tant que le manuel Service n'a pas été consulté et compris.
- Le non-respect de cet avertissement peut entraîner chez le technicien, l'opérateur ou le patient des blessures dues à des dangers électriques, mécaniques ou autres.

WARNUNG

- Dieses Kundendienst-Handbuch existiert nur in englischer Sprache.
- Falls ein fremder Kundendienst eine andere Sprache benötigt, ist es Aufgabe des Kunden für eine entsprechende Übersetzung zu sorgen.
- Versuchen Sie nicht, das Gerät zu reparieren, bevor dieses Kundendienst-Handbuch nicht zu Rate gezogen und verstanden wurde.
- Wird diese Warnung nicht beachtet, so kann es zu Verletzungen des Kundendiensttechnikers, des Bedieners oder des Patienten durch elektrische Schläge, mechanische oder sonstige Gefahren kommen.

AVISO

- Este Manual de Servicio sólo existe en inglés.
- Si algún proveedor de servicios ajeno a GEMS solicita un idioma que no sea el inglés, es responsabilidad del cliente ofrecer un servicio de traducción.
- No se deberá dar servicio técnico al equipo, sin haber consultado y comprendido este manual de servicio.
- La no observancia del presente aviso puede dar lugar a que el proveedor de servicios, el operador o el paciente sufran lesiones provocadas por causas eléctricas, mecánicas o de otra naturaleza.

ATENÇÃO

- Este Manual de Assistência Técnica só se encontra disponível em Inglês.
 - Se qualquer outro serviço de assistência técnica, que não a GEMS, solicitar estes manuais noutra idioma, é da responsabilidade do cliente fornecer os serviços de tradução.
 - Não tente reparar o equipamento sem ter consultado e compreendido este Manual de Assistência Técnica.
 - O não cumprimento deste aviso pode por em perigo a segurança do técnico, operador ou paciente devido a choques elétricos, mecânicos ou outros.
-

AVVERTENZA

- Il presente manuale di manutenzione è disponibile soltanto in inglese.
- Se un addetto alla manutenzione esterno alla GEMS richiede il manuale in una lingua diversa, il cliente è tenuto a provvedere direttamente alla traduzione.
- Si proceda alla manutenzione dell'apparecchiatura solo dopo aver consultato il presente manuale ed averne compreso il contenuto.
- Non tenere conto della presente avvertenza potrebbe far compiere operazioni da cui derivino lesioni all'addetto alla manutenzione, all'utilizzatore ed al paziente per folgorazione elettrica, per urti meccanici od altri rischi.

警告

このサービスマニュアルには英語版しかありません。

GEMS以外でサービスを担当される業者が英語以外の言語を要求される場合、翻訳作業はその業者の責任で行うものとさせていただきます。

このサービスマニュアルを熟読し理解せずに、装置のサービスを行わないで下さい。

この警告に従わない場合、サービスを担当される方、操作員あるいは患者さんが、感電や機械的又はその他の危険により負傷する可能性があります。

注意

本维修手册仅存有英文本。

非 GEMS 公司的维修员要求非英文本的维修手册时，客户需自行负责翻译。

未详细阅读和完全了解本手册之前，不得进行维修。
忽略本注意事项会对维修员，操作员或病人造成触电，机械伤害或其他伤害。

REVISION HISTORY

REV.	DATE	REASON FOR CHANGE
0.0	Mar 2003	First Draft
0.1	Apr 2003	Updated to incorporate review comments
1.0	May 2003	Updated to incorporate review comments
1.1	Aug 05, 2003	Updated based on Review comments from GCC

Intentionally Blank

TABLE OF CONTENTS

1	INTRODUCTION	1-1
1.1	OVERVIEW.....	1-1
1.2	OVERALL CONFORMANCE STATEMENT DOCUMENTATION STRUCTURE.....	1-2
1.3	INTENDED AUDIENCE.....	1-4
1.4	SCOPE AND FIELD OF APPLICATION.....	1-4
1.5	IMPORTANT REMARKS.....	1-5
1.6	REFERENCES.....	1-5
1.7	DEFINITIONS.....	1-6
1.8	SYMBOLS AND ABBREVIATIONS.....	1-6
2	NETWORK CONFORMANCE STATEMENT	2-7
2.1	INTRODUCTION.....	2-7
2.2	IMPLEMENTATION MODEL.....	2-7
2.2.1	<i>Application Data Flow Diagram</i>	2-8
2.2.1.1	CT Application Entity.....	2-8
2.2.1.2	PET Application Entity.....	2-10
2.2.1.3	Xeleris Application Entity.....	2-11
2.2.2	<i>Functional Definition of AE's</i>	2-11
2.2.3	<i>Sequencing of Real-World Activities</i>	2-14
2.2.4	<i>CT Application Entity</i>	2-14
2.2.4.1	AE SPECIFICATIONS.....	2-14
2.2.4.1.1	DICOM Server AE Specification.....	2-14
2.2.4.1.1.1	Association Establishment Policy.....	2-14
2.2.4.1.1.2	Association Initiation by Real-World Activity.....	2-15
2.2.4.1.1.3	Association Acceptance Policy.....	2-22
2.2.4.2	COMMUNICATION PROFILES.....	2-29
2.2.4.2.1	Supported Communication Stacks (parts 8,9).....	2-29
2.2.4.2.2	TCP/IP Stack.....	2-29
2.2.4.2.2.1	Physical Media Support.....	2-29
2.2.4.2.3	Point-to-Point Stack.....	2-30
2.2.4.3	EXTENSIONS / SPECIALIZATIONS / PRIVATIZATIONS – CT Application Entity.....	2-30
2.2.4.3.1	Specialized Information Object Definition.....	2-30
2.2.4.3.2	Private SOP's.....	2-30
2.2.4.3.3	Private Data Elements.....	2-31
2.2.4.4	CONFIGURATION.....	2-31
2.2.4.4.1	AE Title/Presentation Address Mapping.....	2-31
2.2.4.4.2	Configurable Parameters.....	2-32
2.2.4.5	SUPPORT OF EXTENDED CHARACTER SETS.....	2-32
2.2.5	<i>PET Application Entity</i>	2-32
2.2.5.1	AE SPECIFICATIONS - PET Application Entity.....	2-32
2.2.5.1.1.1	Association Establishment Policies - PET Application Entity.....	2-33
2.2.5.1.1.2	Association Initiation Policy - PET Application Entity.....	2-34
2.2.5.1.1.3	Association Acceptance Policy - PET Application Entity.....	2-43
2.2.5.2	COMMUNICATION PROFILES - PET Application Entity.....	2-49
2.2.5.2.1	Supported Communication Stacks (PS 3.8, PS 3.9).....	2-49
2.2.5.2.2	OSI Stack.....	2-49
2.2.5.2.3	TCP/IP Stack.....	2-49
2.2.5.2.3.1	API.....	2-49
2.2.5.2.3.2	Physical Media Support.....	2-49
2.2.5.2.4	Point-to-Point Stack.....	2-49
2.2.5.3	EXTENSIONS / SPECIALIZATIONS / PRIVATIZATIONS - PET Application Entity.....	2-50
2.2.5.3.1	Standard Extended /Specialized/Private SOPs.....	2-50
2.2.5.3.2	Private Transfer Syntaxes.....	2-50
2.2.5.4	CONFIGURATION - PET Application Entity.....	2-50
2.2.5.4.1	AE Title/Presentation Address Mapping.....	2-50
2.2.5.4.2	Configurable Parameters.....	2-50

2.2.5.5	SUPPORT OF EXTENDED CHARACTER SETS - PET Application Entity.....	2-50
2.2.6	<i>Xeleris Application Entity</i>	2-51
2.2.6.1	DICOM AE Specifications.....	2-51
2.2.6.1.1	Association Establishment Policies - Xeleris Application Entity	2-52
2.2.6.1.1.1	General.....	2-52
2.2.6.1.1.2	Number of Associations.....	2-52
2.2.6.1.1.3	Asynchronous Nature.....	2-52
2.2.6.1.1.4	Implementation Identifying Information.....	2-53
2.2.6.1.2	Association Initiation Policies - Xeleris Application Entity.....	2-53
2.2.6.1.2.1	Real-World Activity: Image Send - Xeleris Application Entity.....	2-53
2.2.6.1.2.2	Real-World Activity: Verify - Xeleris Application Entity.....	2-56
2.2.6.1.2.3	Real-World Activity: Query - Xeleris Application Entity.....	2-57
2.2.6.1.2.4	Real-World Activity: Retrieve - Xeleris Application Entity.....	2-59
2.2.6.1.3	Association Acceptance Policy	2-61
2.2.6.1.3.1	Real-World Activity: Image Storage SCP - Xeleris Application Entity	2-62
2.2.6.1.3.2	Real-World Activity: Query SCP - Xeleris Application Entity.....	2-64
2.2.6.1.3.3	Real-World Activity: Image Retrieve SCP - Xeleris Application Entity	2-66
2.2.6.1.3.4	Real-World Activity: Verify SCP - Xeleris Application Entity	2-68
2.2.6.2	Communication Profiles - Xeleris Application Entity	2-69
2.2.6.2.1	Support Communication Stacks (PS 3.8, PS 3.9).....	2-69
2.2.6.2.2	OSI Stack.....	2-69
2.2.6.2.3	TCP/IP Stack	2-69
2.2.6.2.4	API.....	2-69
2.2.6.2.5	Physical Media Support	2-69
2.2.6.2.6	Point-to-Point Stack	2-69
2.2.6.3	Extentions/Privatizations/Specialization - Xeleris Application Entity.....	2-69
2.2.6.3.1	Standard Extended/Specialized/Private SOPs.....	2-69
2.2.6.3.2	Private Transfer Syntaxes.....	2-69
2.2.6.4	Configurations - Xeleris Application Entity.....	2-69
2.2.6.4.1	AE Title/Presentation Address Mapping.....	2-69
2.2.6.4.2	Configuration Parameters	2-70
2.2.6.5	Support of Extended Character Sets	2-70
2.3	CODES AND CONTROLLED TERMINOLOGY	2-70
2.4	SECURITY PROFILES.....	2-70
3	MEDIA STORAGE CONFORMANCE STATEMENT	3-72
3.1.1	<i>Introduction</i>	3-72
3.1.2	<i>Implementation Model: MOD Archive Server</i>	3-72
3.1.2.1	Application Data Flow Diagram	3-72
3.1.2.2	Functional Definitions of AE's.....	3-73
3.1.2.3	Sequencing of Real World Activities.....	3-73
3.1.2.4	File Meta Information for Implementation Class and Version	3-73
3.1.3	<i>AE Specifications</i>	3-73
3.1.3.1	MOD Archive Specification.....	3-73
3.1.3.1.1	File Meta Information for the Application Entity.....	3-74
3.1.3.1.2	Real World Activities	3-74
3.1.3.1.2.1	Real World Activity: Create MOD Request	3-74
3.1.3.1.2.2	Real World Activity: Display Directory.....	3-75
3.1.3.1.2.3	Real World Activity: Copy to Local Storage	3-76
3.1.3.1.2.4	Real World Activity: Update MOD.....	3-77
3.1.4	<i>Augmented and Private Application Profiles</i>	3-77
3.1.4.1	Augmented Application Profiles.....	3-77
3.1.4.1.1	AUG-CTMR-MOD12 and AUG-CTMR-MOD23 Application Profiles	3-77
3.1.4.1.1.1	SOP Classes and Transfer Syntaxes	3-77
3.1.4.1.1.2	Directory Information in DICOMDIR	3-78
3.1.4.1.1.3	Other Parameters	3-78
3.1.4.2	Private Application Profiles	3-78
3.1.4.2.1	PRI-CTMR-MOD12 Private Application Profile	3-78
3.1.4.2.1.1	Roles and Service Class Options	3-79
3.1.4.2.1.2	SOP Classes and Transfer Syntax	3-79
3.1.4.2.1.3	Physical Media and Media Formats.....	3-79
3.1.4.2.1.4	Directory Information in DICOMDIR	3-79

3.1.4.2.1.5	Other Parameters	3-79
3.1.5	<i>Extensions, Specializations and Privatization of SOP Classes and Transfer Syntax</i> ..	3-80
3.1.5.1	Extensions, Specialization's and Privatization's of SOP Classes	3-80
3.1.5.1.1	SOP Specific Conformance Statement for CT SOP Class	3-80
3.1.5.1.2	SOP Specific Conformance Statement for MR SOP Class	3-80
3.1.6	<i>Configuration</i>	3-80
3.1.7	<i>Support of Extended Character Sets</i>	3-80
4	PRINT SCU CONFORMANCE	4-81
4.1.1	<i>Introduction</i>	4-81
4.1.2	IMPLEMENTATION MODEL : PRINT SCU	4-81
4.1.2.1	Application Data Flow Diagram	4-81
4.1.2.2	Functional Definition of AE's	4-81
4.1.2.3	Sequencing of Real-World Activities	4-82
4.1.3	AE SPECIFICATIONS	4-82
4.1.3.1	DICOM Print SCU AE Specification	4-82
4.1.3.1.1	Association Establishment Policy	4-82
4.1.3.1.1.1	General	4-83
4.1.3.1.1.2	Number of Associations	4-83
4.1.3.1.1.3	Asynchronous Nature	4-83
4.1.3.1.1.4	Implementation identifying information	4-83
4.1.3.1.2	Association Establishment Policy	4-83
4.1.3.1.2.1	Real World Activity	4-83
4.1.3.1.2.2	SOP Specific Conformance Statement	4-84
4.1.3.1.3	Association Acceptance Policy	4-88
4.1.4	COMMUNICATION PROFILES	4-88
4.1.4.1	Supported Communication Stacks (parts 8,9)	4-89
4.1.4.1.1	TCP/IP Stack	4-89
4.1.4.1.1.1	API	4-89
4.1.4.1.1.2	Physical Media Support	4-89
4.1.5	<i>Standard Extended/Specialized/Private SOPs</i>	4-89
4.1.6	<i>Configuration</i>	4-89
4.1.6.1	AE Title/Presentation Address Mapping	4-89
4.1.6.2	Configurable Parameters	4-89
4.1.7	<i>Support of Extended Character Set</i>	4-90
5	STORAGE COMMITMENT CONFORMANCE	5-91
5.1.1	<i>Introduction</i>	5-91
5.1.2	<i>Implementation Model</i>	5-91
5.1.2.1	Application data flow diagram	5-91
5.1.2.2	Functional definitions	5-92
5.1.2.3	Sequencing of real-world activities	5-92
5.1.3	AE Specifications	5-92
5.1.3.1	DICOM Server AE specifications	5-92
5.1.3.1.1	Association establishment policies	5-92
5.1.3.1.2	Association initiation policy	5-92
5.1.3.1.3	Real World Activity	5-92
5.1.3.1.3.1	Associated Real World Activity - "Save exam/series"	5-92
5.1.3.1.3.2	Associated Real World Activity - "Auto Archive exam/series"	5-93
5.1.3.1.4	Proposed Presentation Contexts	5-93
5.1.3.1.5	Request Processing	5-93
5.1.3.1.6	Response Processing	5-94
5.1.3.1.6.1	Commit response with SUCCESS status	5-94
5.1.3.1.6.2	Commit response with FAILURE status	5-95
5.1.3.1.7	Association Acceptance Policy	5-95
6	MODALITY WORK LIST CONFORMANCE	6-96
6.1.1	INTRODUCTION	6-96
6.1.2	IMPLEMENTATION MODEL	6-96
6.1.2.1	Application Data Flow Diagram	6-96

6.1.2.2	Functional definitions	6-96
6.1.2.3	Sequencing of Real-World Activities	6-97
6.1.3	AE SPECIFICATIONS	6-97
6.1.3.1	Worklist Server AE Specification	6-97
6.1.3.1.1	Association Establishment Policies	6-97
6.1.3.1.1.1	General	6-97
6.1.3.1.1.2	Number of Associations	6-97
6.1.3.1.1.3	Asynchronous Nature	6-97
6.1.3.1.1.4	Implementation Identifying Information	6-98
6.1.3.1.2	Association Initiation Policy	6-98
6.1.3.1.2.1	Real-World Activity: Worklist Query	6-98
6.1.3.1.3	Association Acceptance Policy	6-101
6.1.4	COMMUNICATION PROFILES	6-101
6.1.4.1	Supported Communication Stacks (PS 3.8, PS 3.9)	6-101
6.1.4.2	OSI Stack	6-101
6.1.4.3	TCP/IP Stack	6-101
6.1.4.3.1	API	6-101
6.1.4.3.2	Physical Media Support	6-101
6.1.4.4	Point-to-Point Stack	6-101
6.1.5	EXTENSIONS / SPECIALIZATIONS / PRIVATIZATIONS	6-101
6.1.5.1	Standard Extended /Specialized/Private SOPs	6-101
6.1.5.2	Private Transfer Syntaxes	6-101
6.1.6	CONFIGURATION	6-101
6.1.6.1	AE Title/Presentation Address Mapping	6-102
6.1.6.2	Configurable Parameters	6-102
6.1.7	SUPPORT OF EXTENDED CHARACTER SETS	6-102
6.1.8	Modality Worklist INFORMATION MODEL Definition	6-102
6.1.8.1	ModalityWorklist Mapping of DICOM Entities	6-102
6.1.8.2	Information Model MODULE TABLE	6-103
6.1.8.3	INFORMATION Model Keys	6-103
6.1.8.4	Supported Matching	6-104
6.1.8.5	Scheduled Procedure Step Entity	6-104
6.1.8.5.1	SOP Common Module	6-104
6.1.8.5.2	Scheduled Procedure Step Module	6-104
6.1.8.6	Requested Procedure Entity	6-105
6.1.8.6.1	Requested Procedure Module	6-105
6.1.8.7	Imaging Service Request Entity	6-106
6.1.8.7.1	Imaging Service Request Module	6-106
6.1.8.8	Visit Entity	6-107
6.1.8.8.1	Visit Identification	6-107
6.1.8.8.2	Visit Status	6-107
6.1.8.8.3	Visit Relationship	6-108
6.1.8.8.4	Visit Admission	6-108
6.1.8.9	Patient Entity	6-108
6.1.8.9.1	Patient Relationship	6-108
6.1.8.9.2	Patient Identification	6-108
6.1.8.9.3	Patient Medical	6-109
6.1.9	<i>Private data dictionary</i>	6-109
6.1.10	<i>C-FIND Request Message</i>	6-109
6.1.11	<i>Use of Specific DICOM Data</i>	6-112
6.1.12	<i>Setting User Preferences</i>	6-113
6.1.12.1	Setting "Use MWL Study UID" Option	6-113
6.1.12.2	Setting Custom Query Option	6-113
7	PERFORMED PROCEDURE STEP CONFORMANCE STATEMENT	7-114
7.1.1	INTRODUCTION	7-114
7.1.2	IMPLEMENTATION MODEL	7-114
7.1.2.1	APPLICATION DATA FLOW DIAGRAM	7-114
7.1.2.2	Functional Definition of AEs	7-115
7.1.2.3	Sequencing of Real-World Activities	7-115
7.1.2.3.1	PPS from acquisition system with MWL data	7-115

7.1.2.3.2	PPS from acquisition system without MWL data	7-116
7.1.2.3.3	PPS from post-processing system	7-117
7.1.3	AE SPECIFICATION	7-117
7.1.3.1	PPS Server AE Specification	7-117
7.1.3.1.1	Association Establishment Policies	7-117
7.1.3.1.1.1	General	7-117
7.1.3.1.1.2	Number of Associations	7-118
7.1.3.1.1.3	Asynchronous Nature	7-118
7.1.3.1.1.4	Implementation Identifying information	7-118
7.1.3.1.2	Association Initiation Policy	7-118
7.1.3.1.2.1	Real-World Activity: Performed Procedure Step creation and update	7-118
7.1.3.1.3	Association Acceptance Policy	7-119
7.1.4	COMMUNICATION PROFILES	7-119
7.1.4.1	Supported Communication Stacks (PS 3.8)	7-119
7.1.4.2	OSI Stack	7-119
7.1.4.3	TCP/IP Stack	7-119
7.1.4.3.1	API	7-119
7.1.4.3.2	Physical Media Support	7-119
7.1.4.4	Point-to-Point Stack	7-119
7.1.5	EXTENSIONS/SPECIALIZATION/PRIVATIZATION	7-119
7.1.5.1	Standard Extended/Specialized/Private SOPs	7-119
7.1.5.2	Private Transfer Syntaxes	7-119
7.1.6	CONFIGURATION	7-120
7.1.6.1	AE Title/Presentation address Mapping	7-120
7.1.6.2	Configurable Parameters	7-120
7.1.7	SUPPORT OF EXTENDED CHARACTER SETS	7-120
7.1.8	N-CREATE & NSET REQUEST MESSAGE	7-120
7.1.9	ERROR HANDLING AND RECOVERY	7-122
7.1.10	USE OF SPECIFIC DICOM DATA	7-122
7.1.11	USE OF SPECIFIC DICOM DATA	7-125
A	CT/MR IOD DEFINITIONS	1
A.1	CT SPECIFIC IOD DEFINITION	1
A.1.1	CT Image IOD Modules	1
A.1.2	CT Image Module	1
A.2	MR SPECIFIC IOD DEFINITION	3
A.2.1	MR Image IOD Modules	3
A.2.2	MR Image Module	3
A.3	SC SPECIFIC IOD DEFINITION	4
A.3.1	SC Image IOD Modules	4
A.4	CT/MR/SC IOD COMMON MODULE DEFINITIONS	4
A.4.1	Patient Module	4
A.4.2	General Study Module	5
A.4.3	Patient Study Module	5
A.4.4	General Series Module	5
A.4.5	General Equipment Module	6
A.4.6	General Image Module	6
A.4.7	Image Plane Module	7
A.4.8	Contrast Bolus Module	7
A.4.9	SOP Common Module	7
A.4.10	Overlay Plane Module	7
A.4.11	VOI LUT Module	7
A.4.12	Frame of Reference Module	7
A.4.13	SC Equipment Module	8
A.5	CT IMAGE IOD PRIVATE DATA ELEMENTS DEFINITION	8
A.5.1	Private Creator Identification (GEMS_IDEN_01)	8
A.5.2	Private Creator Identification (GEMS_ACQU_01)	8
A.5.3	Private Creator Identification (GEMS_RELA_01)	9

A.5.4	Private Creator Identification (GEMS_STDY_01).....	9
A.5.5	Private Creator Identification (GEMS_IMAG_01).....	9
A.5.6	Private Creator Identification (GEMS_PARM_01).....	9
A.5.7	Private Creator Identification(GEMS_HELIOS_01).....	10
A.5.8	Private Creator Identification (GEMS_CT_CARDIAC_001).....	11
A.5.9	Private Creator Identification (GEMS_CT_VES_01).....	11
A.6	MR IMAGE IOD PRIVATE DATA ELEMENTS DEFINITION.....	11
A.6.1	Private Creator Identification (GEMS_IDEN_01).....	11
A.6.2	Private Creator Identification (GEMS_PATI_01).....	12
A.6.3	Private Creator Identification (GEMS_ACQU_01).....	12
A.6.4	Private Creator Identification (GEMS_RELA_01).....	14
A.6.5	Private Creator Identification (GEMS_STDY_01).....	14
A.6.6	Private Creator Identification (GEMS_SERS_01).....	15
A.6.7	Private Creator Identification (GEMS_IMAG_01).....	15
A.6.8	Private Creator Identification (GEMS_IMPS_01).....	16
A.6.9	Private Creator Identification (GEMS_PARM_01).....	16
B	PET IOD DEFINITIONS.....	17
B.1	PET SPECIFIC IOD DEFINITIONS.....	17
B.1.1	PET IMAGE IOD Implementation.....	17
B.1.2	PET IMAGE Entity-Relationship Model.....	17
B.1.3	PET IMAGE IOD MODULE TABLE.....	19
B.1.4	PET IMAGE INFORMATION MODULE DEFINITIONS.....	20
B.2	PRIVATE DATA DICTIONARY.....	40
B.2.1	Private Creator Identification Information.....	40
B.2.2	GE Discovery ST PET Patient Module.....	40
B.2.3	GE Discovery ST PET Exam Module.....	41
B.2.4	GE Discovery ST PET Scan Module.....	41
B.2.5	GE Discovery ST PET Frame Module.....	45
B.2.6	GE Discovery ST PET ImageSet Module.....	46
B.2.7	GE Discovery ST PET Image Module.....	49
B.2.8	GE Discovery ST PET ROI Module.....	50
B.2.9	GE Discovery ST PET Annotation Module.....	51
B.3	PRIVATE DATA ELEMENTS.....	52
C	DICOMDIR DIRECTORY INFORMATION.....	52
C.1	BASIC DIRECTORY IOD DEFINITION.....	52
C.2	DIRECTORY INFORMATION MODULE.....	52
C.3	DIRECTORY RECORD SELECTION KEYS.....	52
C.3.1	Patient Keys.....	53
C.3.2	Study Keys.....	53
C.3.3	Series Keys.....	53
C.3.4	Image Keys.....	53
D	STANDALONE PET CURVE INFORMATION OBJECT IMPLEMENTATION.....	55
D.1	INTRODUCTION.....	55
D.2	PET CURVE IOD IMPLEMENTATION.....	55
D.3	PET CURVE ENTITY-RELATIONSHIP MODEL.....	55
D.3.1	ENTITY DESCRIPTIONS.....	56
D.3.2	GE Discovery ST PET AE Mapping of DICOM entities.....	57
D.4	PET CURVE IOD MODULE TABLE.....	57
D.5	PET CURVE INFORMATION MODULE DEFINITIONS.....	58
D.5.1	Common Patient Entity Modules.....	58
D.5.2	Common Study Entity Modules.....	59
D.5.3	Common Series Entity Modules.....	61

D.5.4	Common Equipment Entity Modules.....	67
D.5.5	Common Curve Entity Modules	68
D.5.6	General Modules.....	72
D.6	PRIVATE DATA DICTIONARY	74
D.6.1	Private Creator Identification Information	74
D.6.2	GE Discovery ST PET Patient Module	74
D.6.3	GE Discovery ST PET Exam Module	74
D.6.4	GE Discovery ST PET Scan Module	75
D.6.5	GE Discovery ST PET Frame Module	78
D.6.6	GE Discovery ST PET ImageSet Module	79
D.6.7	GE Discovery ST PET Curve Module.....	82
D.6.8	GE Discovery ST PET Graph Module.....	83
D.6.9	GE Discovery ST PET Curve Presentation Module.....	84
E	PATIENT ROOT QUERY/RETRIEVE INFORMATION MODEL DEFINITION	85
E.1	INTRODUCTION.....	85
E.2	PATIENT ROOT INFORMATION MODEL DESCRIPTION	85
E.3	PATIENT ROOT INFORMATION MODEL ENTITY-RELATIONSHIP MODEL	85
E.3.1	ENTITY DESCRIPTIONS	86
E.3.2	GE Discovery ST PET AE Mapping of DICOM entities	87
E.4	INFORMATION MODEL KEYS.....	87
E.4.1	Supported Matching.....	87
E.4.2	Patient Level	88
E.4.3	Study Level	88
E.4.4	Series Level	89
E.4.5	Image Level.....	89
E.4.6	Private data dictionary	90
F	STUDY ROOT QUERY/RETRIEVE INFORMATION MODEL DEFINITION	90
F.1	INTRODUCTION.....	90
F.2	STUDY ROOT INFORMATION MODEL DESCRIPTION.....	90
F.3	STUDY ROOT INFORMATION MODEL ENTITY-RELATIONSHIP MODEL.....	91
F.3.1	Entity Descriptions	92
F.3.2	GE Discovery ST PET AE Mapping of DICOM entities	93
F.4	INFORMATION MODEL KEYS.....	93
F.4.1	Supported Matching.....	93
F.4.2	Study Level	93
F.4.3	Series Level	94
F.4.4	Image Level.....	95
F.4.5	Private data dictionary	95
G	STANDALONE CURVE INFORMATION OBJECT IMPLEMENTATION	96
G.1	INTRODUCTION.....	96
G.2	STANDALONE CURVE IOD IMPLEMENTATION	96
G.3	STANDALONE CURVE ENTITY-RELATIONSHIP MODEL	96
G.3.1	ENTITY DESCRIPTIONS	97
G.3.2	GE Discovery ST PET AE Mapping of DICOM entities	98
G.4	STANDALONE CURVE IOD MODULE TABLE.....	98
G.5	STANDALONE CURVE INFORMATION MODULE DEFINITIONS.....	99
G.5.1	Common Patient Entity Modules.....	99
G.5.2	Common Study Entity Modules.....	100
G.5.3	Common Series Entity Modules.....	102
G.5.4	Common Equipment Entity Modules.....	104
G.5.5	Common Curve Entity Modules	105
G.5.6	General Modules.....	108

G.6	PRIVATE DATA DICTIONARY	109
G.6.1	Private Creator Identification Information	109
G.6.2	GE Discovery ST PET Patient Module	109
G.6.3	GE Discovery ST PET Exam Module	109
G.6.4	GE Discovery ST PET Scan Module	110
G.6.5	GE Discovery ST PET ImageSet Module	113
G.6.6	GE Discovery ST PET Curve Module	116
G.6.7	GE Discovery ST PET Graph Module.....	117
G.6.8	GE Discovery ST PET Curve Presentation Module.....	118
H	GE PRIVATE PET RAW DATA INFORMATION OBJECT IMPLEMENTATION.....	120
H.1	INTRODUCTION.....	120
H.2	GE PRIVATE PET RAW DATA IOD ENTITY-RELATIONSHIP MODEL	120
H.2.1	ENTITY DESCRIPTIONS	121
H.2.2	GE Discovery ST PET AE Mapping of DICOM entities	122
H.3	GE PRIVATE PET RAW DATA IOD MODULE TABLE	122
H.4	GE PRIVATE PET RAW DATA INFORMATION MODULE DEFINITIONS	123
H.4.1	GE Discovery ST PET RAW Data Patient Entity Module	123
H.4.2	GE Discovery ST PET RAW Data Exam Module	124
H.4.3	GE Discovery ST PET RAW Data Scan Entity Modules	124
H.4.4	GE Discovery ST PET RAW Data Equipment Entity Modules	125
H.4.5	GE Discovery ST PET RAW Data Frame Entity Modules	125
H.4.6	General Modules.....	126

Intentionally Blank

1 INTRODUCTION

This DICOM Conformance Statement specifies the compliance to DICOM conformance requirements for the relevant features (Networking, Media, Print SCU etc) on this GEMS product. Note that the format of this section strictly follows the format defined in DICOM Standard PS 3.2 (Conformance). Please refer to that part of the standard while reading this section. The Discovery ST product provides sophisticated networking, image processing and storage functions on CT/PET data. In view of the requirements to conform to a global standard that permits interoperability across equipment produced by different vendors, Discovery ST will provide support for DICOM.

Discovery ST provides a flexible design to fully utilize all features of individual components of Hybrid PET/CT scanner. This is achieved through an integration of three different Application Entities (AEs). The three Application Entities work independently and provide functionalities specific to CT standalone system, PET standalone system and Advanced Review & processing station.

This document has three sections, each of which will discuss the Services provided by each AE in detail. The IODs for each AE is provided at the Appendix.

1.1 Overview

Section 1, *General Introduction and Content Organization*, provides general information about the content and scope of this document. Conformance Statements define the subset of options selected from those offered by the DICOM standard

Section 2, *Network DICOM Conformance*, is the DICOM Conformance Statement for network functionality of this product. This section covers details about 3 Application Entities that provide network functionality for Discovery ST product.

Section 3, *Media Storage Conformance*, covers the DICOM Conformance Statement related to Media Storage Application Profile.

Section 4, *Print SCU Conformance*, is the DICOM Conformance Statement related to DICOM Print SCU Application. This product uses DICOM Print SCU to print the images to DICOM Compliant Printers

Section 5, *Storage Commitment Conformance*, is the DICOM Conformance Statement related to DICOM Storage Commitment implementation on this product.

Section 6, *Modality Worklist Conformance*, is the DICOM Conformance Statement related to DICOM Modality Worklist implementation on this product.

Section 7, *Performed Procedure Step Conformance*, is the DICOM Conformance Statement related to DICOM Modality Performed Procedure Step implementation on this product.

Section 8, *Performed Procedure Step Conformance*, is the DICOM Conformance Statement related to DICOM Modality Performed Procedure Step implementation on this product.

Appendix A, IOD Definitions for CT, MR Information Objects

Appendix B, IOD Definitions for PET Image Information Object

Appendix C, DICOMDIR Directory Information for Media Storage Service

Appendix D, IOD Definitions for Standalone PET Curve IOD

Appendix E, Patient Root Query Retrieve Information Model Definition

Appendix F, Study Root Query Retrieve Information Model Definition

Appendix G, IOD Definitions for Standalone Curve IOD Implementation

Appendix H, IOD Definitions for GE Private PET RAW Data IOD

1.2 Overall Conformance Statement Documentation Structure

The documentation structure of the ID/Net v3.0 Conformance Statements and their relationship with the DICOM Conformance Statements is shown in Illustration 1-1.

ID/Net v3.0

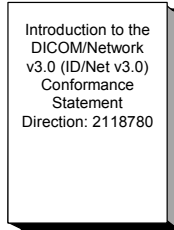

APPLICATION ENTITY SPECIFICATION
(SERVICE CLASSES, INFORMATION OBJECTS, MESSAGE EXCHANGES, ETC.)

**Product
Implementation:**

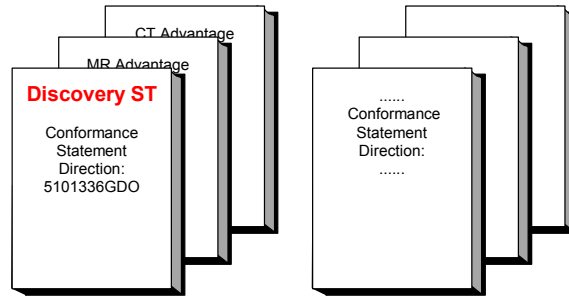

DICOM STANDARD

**Standard
Specification:**

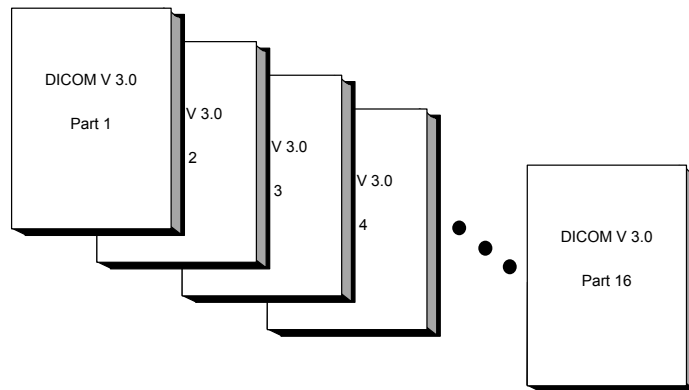

This document specifies the DICOM implementation supported by the Discovery ST. It is entitled:

Discovery ST Conformance Statement for DICOM (ID/Net v3.0), Direction 5101336GDO

This Conformance Statement documents the DICOM Conformance Statement and Technical Specification required to interoperate with the GE ID/Net v3.0 network interface. Introductory

information, which is applicable to all GE ID/Net v3.0 Conformance Statements, is described in the document:

Introduction to the DICOM/Network v3.0 (ID/Net v3.0) Conformance Statements, Direction 2118780

This introduction familiarizes the reader with DICOM terminology and general concepts. It should be read prior to reading individual products' ID/Net v3.0 Conformance Statements.

The ID/Net v3.0 Conformance Statement, contained in this document, also specifies the Lower Layer communications that it supports (e.g. TCP/IP). However, the Technical Specifications are defined in the DICOM Part 8 standard.

For more information including Network Architecture and basic DICOM concepts, please refer to the *Introduction*.

For more information regarding DICOM, copies of the Standard may be obtained on the Internet at <http://medical.nema.org>. Comments on the Standard may be addressed to:

DICOM Secretariat
NEMA
1300 N. 17th Street, Suite 1847
Rosslyn, VA 22209
USA
Phone: +1.703.841.3200

1.3 Intended Audience

The reader of this document is concerned with software design and/or system integration issues. It is assumed that the reader of this document is familiar with the DICOM standards and with the terminology and concepts that are used in those standards.

If readers are unfamiliar with DICOM terminology they should first refer to the document listed below, then read the DICOM Standard itself, prior to reading this Conformance Statement document.

Introduction to the DICOM/Network v3.0 (ID/Net v3.0) Conformance Statements Direction 2118780

1.4 Scope and Field of Application

It is the intent of this document, in conjunction with the *Introduction to the Integrated DICOM/Network v3.0 (ID/Net v3.0) Conformance Statements Direction 2118780*, to provide an unambiguous specification for GE ID/Net v3.0 implementations. This specification, called a Conformance Statement, includes a DICOM Conformance Statement and is necessary to insure proper processing and interpretation of GE medical image data exchanged using DICOM. The GE ID/Net v3.0 Conformance Statements are available to the public.

The reader of this conformance statement should be aware that different GE devices are capable of using different Information Object Definitions. For example, a GE CT scanner may send images using the CT Information Object, MR Information Object, Secondary Capture Object, etc.

Included in this Conformance Statement are Module Definitions which define all data elements used by the GE ID/Net v3.0 implementation. If the user encounters unspecified private data elements while parsing a GE Data Set, the user is well advised to ignore those data elements

(per the DICOM standard). Unspecified private data element information is subject to change without notice. If, however, the device is acting as a “full fidelity storage device”, it should retain and retransmit all of the private data elements which are sent by GE devices.

1.5 Important Remarks

The use of these Conformance Statements, in conjunction with the DICOM Standards, is intended to facilitate communication with GE imaging equipment. However, **by it self, it is not sufficient to insure that inter-operation will be successful.** The **user (or user’s agent)** needs to proceed with caution and address at least four issues:

- **Integration** - The integration of any device into an overall system of interconnected devices goes beyond the scope of standards (DICOM), and of this introduction and associated Conformance Statements when interoperability with non-GE equipment is desired. The responsibility to analyze the applications requirements and to design a solution that integrates GE imaging equipment with non-GE systems is the **user’s** responsibility and should not be underestimated. The **user** is strongly advised to ensure that such integration analysis is correctly performed.
- **Validation** - Testing the complete range of possible interactions between any GE device and non-GE devices, before the connection is declared operational, should not be overlooked. Therefore, the **user** should ensure that any non-GE provider accepts full responsibility for all validation required for their connection with GE devices. This includes the accuracy of the image data once it has crossed the interface between the GE imaging equipment and the non-GE device and the stability of the image data for the intended applications.
Such a validation is required before any clinical use (diagnosis and/or treatment) is performed. It applies when images acquired on GE imaging equipment are processed/displayed on a non-GE device, as well as when images acquired on non-GE equipment is processed/displayed on a GE console or workstation.
- **Future Evolution** - GE understands that the DICOM Standard will evolve to meet the user’s growing requirements. GE is actively involved in the development of the DICOM Standard. DICOM will incorporate new features and technologies and GE may follow the evolution of the Standard. ID/Net v3.0 is based on DICOM as specified in each ID/Net DICOM Conformance Statement. Evolution of the Standard may require changes to devices which have implemented DICOM. In addition, GE reserves the right to discontinue or make changes to the support of communications features (on its products) reflected on by these ID/Net DICOM Conformance Statements. The **user** should ensure that any non-GE provider, which connects with GE devices, also plans future evolution of the DICOM standard. Failure to do so will likely result in the loss of function and/or connectivity as the DICOM Standard changes and GE products are enhanced to support these changes.
- **Interaction** - It is the sole responsibility of the **non-GE provider** to ensure that communications with the interfaced equipment does not cause degradation of GE imaging equipment performance and/or function.

1.6 References

A list of references which is applicable to all ID/Net v3.0 Conformance Statements is included in the *Introduction to the Integrated DICOM/Network v3.0 (ID/Net v3.0) Conformance Statements Direction 2118780*.

1.7 Definitions

A set of definitions applicable to all ID/Net v3.0 Conformance Statements is included in the *Introduction to the Integrated DICOM/Network v3.0 (ID/Net v3.0) Conformance Statements Direction 2118780*.

1.8 Symbols and Abbreviations

A list of symbols and abbreviations which is applicable to all ID/Net v3.0 Conformance Statements is included in the *Introduction to the Integrated DICOM/Network v3.0 (ID/Net v3.0) Conformance Statements Direction 2118780*.

2 NETWORK CONFORMANCE STATEMENT

2.1 INTRODUCTION

This section of the DICOM Conformance Statement specifies the Discovery ST compliance to DICOM conformance requirements for the relevant **Networking** features on this GEMS product. Note that the format of this section strictly follows the format defined in DICOM Standard PS 3.2 (Conformance). Please refer to that part of the standard while reading this section. It details the DICOM Service Classes and roles that are supported by this product.

The Discovery ST product uses DICOM services to import images for possible further analysis and/or processing. It also uses DICOM services to export images to other DICOM-compliant systems.

User has the capability to create and display Secondary Capture images, and transfer Secondary Capture images via DICOM. The Secondary Capture option allows the user to capture and store, in DICOM format, the presentation state of images as they are displayed on the Image Display viewer. This provides the user with a digital alternative to hardcopy filming: important portions of the study can be captured and stored on a PACS or analysis workstation rather than captured on film.

The ability to Receive DICOM CT/MR images onto the Discovery ST scanner allows users to co-register and fuse the anatomical detail of the CT/MR images with the Functional PET images – through offline registration. The PET/CT images produced by Discovery ST are perfectly aligned and fusion registration will be seamless.

The Discovery ST DICOM implementation allows the user to send CT/MR/PET Images, PET Curve, Secondary Capture image data through the acquisition system or received from any other DICOM Compliant system to another DICOM station. Discovery ST also allows query and retrieve of data stored in its local database from a remote station and can query and retrieve images stored in a remote DICOM station. In this situation Discovery ST is providing the DICOM C-FIND and C-MOVE services as a service class provider (SCP) and that of a DICOM C-FIND and C-MOVE service class user (SCU). Connect Pro option provides additional capabilities Modality Worklist (MWL) and Performed Procedure Step (MPPS), which provide integration of this GEMS imaging equipment with Hospital Information System.

2.2 IMPLEMENTATION MODEL

Three Application Entities namely CT DICOM AE, PET DICOM AE, and Xeleris DICOM AE handle all DICOM functionality on the DISCOVERY ST product. The DICOM AEs are commanded to perform DICOM services through the buttons and menu selections on the main user interface panel. The AEs are also listening to pre-defined ports for incoming connections.

The following table illustrates the services provided by each AE.

Application Entity	Service/Role	IODs supported
CT DICOM Server AE	C-STORE SCU	CT, MR, SC
	C-STORE SCP	CT, MR, SC
	Query Retrieve SCU	CT, MR, SC
	Query Retrieve SCP	CT, MR, SC
	Media Storage (MOD) FSC/FSR	CT, MR, SC
	DICOM Print SCU	CT, MR, SC

Application Entity	Service/Role	IODs supported
	Storage Commitment SCU	CT, MR, SC
	Modality Worklist SCU	
	Performed Procedure Step SCU	
PET DICOM Server AE	C-STORE SCU	PET ¹ , SC
	C-STORE SCP	PET ¹ , CT, MR, SC
	Query Retrieve SCU	PET ¹ , CT, MR, SC
	Query Retrieve SCP	PET ¹ , SC
Xeleris DICOM Server AE	C-STORE SCU	PET ¹ , CT, MR, SC
	C-STORE SCP	PET ¹ , CT, MR, SC
	Query Retrieve SCU	PET ¹ , CT, MR, SC
	Query Retrieve SCP	PET ¹ , CT, MR, SC
	Media Storage (MOD) FSC/FSR	PET ¹ , CT, MR, SC
	DICOM Print SCU	PET ¹ , CT, MR, SC
	Storage Commitment SCU	PET ¹ , CT, MR, SC

2.2.1 Application Data Flow Diagram

The Basic and Specific Application models for Send/Receive/Query-Retrieve CT,MR, PET and Secondary Capture Images by each of the Application Entities are described in the following sections.

2.2.1.1 CT Application Entity

There are five Real-World Activities that will cause the CT DICOM Server Application Entity (DICOM Server AE) to initiate a DICOM association to a remote DICOM Application Entity.

The *Choose "Push" Option* Real-World activity consists of an operator selecting one or more study, series or image in the local database manager and choosing either "Push Examination", "Push Series" or "Push Image from the "Network" pull-down menu on the local database manager to send the image(s) to a selected destination.

Real-World Activity, *Query Remote*, causes the DICOM Server AE to initiate an association to the Remote DICOM AE and request the list of all studies. Once the DICOM Server AE receives the list of studies, it will select the first study (as determined through the local database manager list sort criterion) and request the list of series for that study. After receiving the list of series the DICOM Server AE will ask for the list of images for the first series in the list. The operator can then select any study in the study list to retrieve the list of series and images.

Real-World Activity, *Choose "Get" Option*, will be available once the *Query Remote* activity is performed. The operator can now select one or more study (series or image) and ask the DICOM Server AE to retrieve the selected image(s) from the Remote DICOM AE by choosing either "Get Examination", "Get Series", or "Get Images".

Real-World Activity, *Choose "Ping DICOM host" Option*, consists of an operator selecting "Ping DICOM host" from the "Network" pull down menu. This will cause the DICOM Server AE to initiate a "DICOM Verification Request" to the remote AE, to verify the remote system activeness.

¹ PET in this table implies PET Image IOD, PET Curve IOD, and GE Private PET RAW IOD

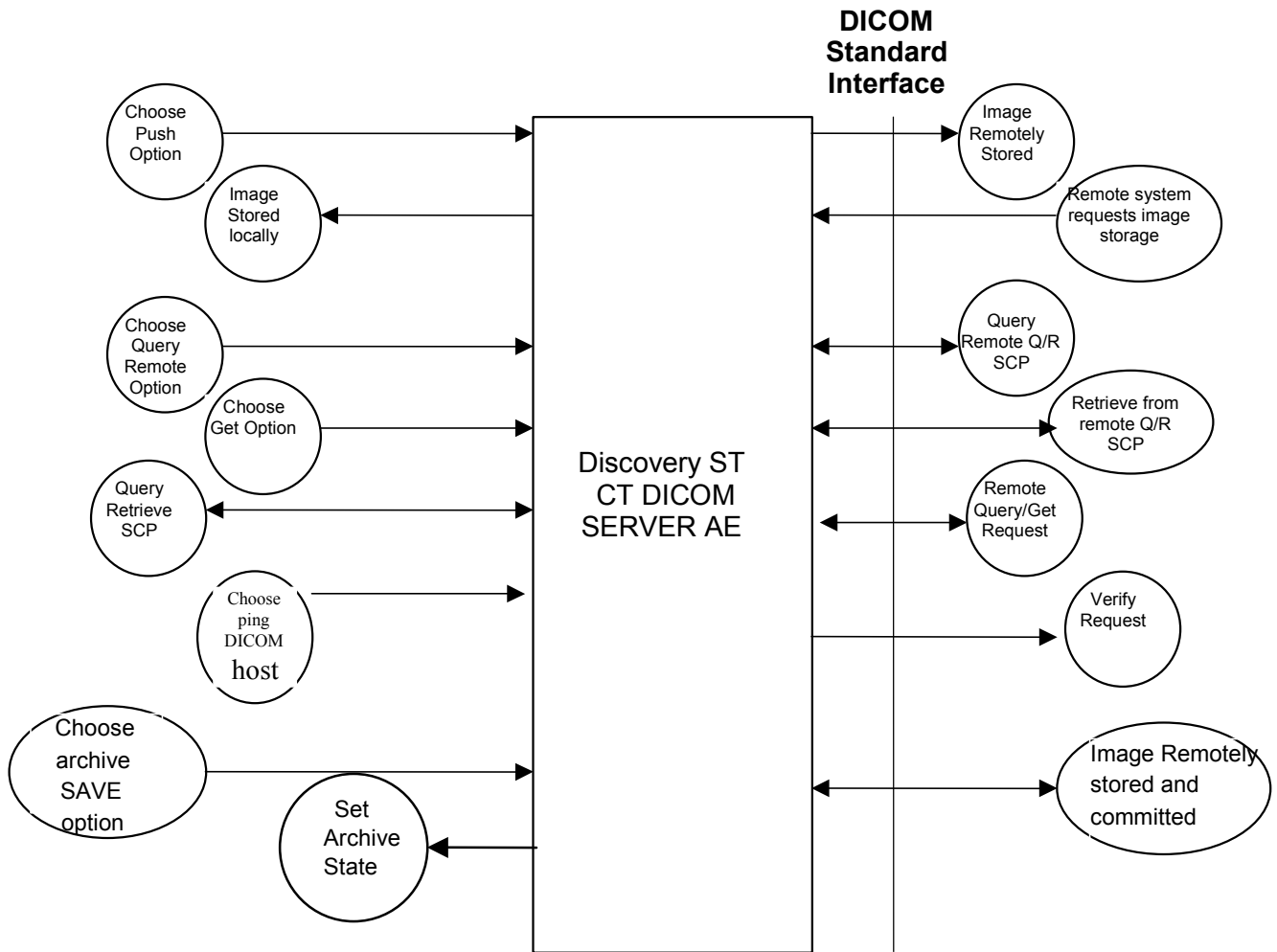

The *Choose “storage commitment” Option* Real-World activity consists of an operator configuring the remote node as an *“archive node”* . Select “choose media” option under “Archive” pull down menu. Select “Remote Node” in that menu. Select one or more study, series or image in the local database manager and choose either “Save Exam” or “Save Series” from the “Archive” pull down menu. This will cause the DICOM server AE to send the image(s) to the selected destination and wait for the storage commitment from the remote node. The remote node should be a storage commitment provider.

There is no Real-World activity required for the DICOM Server AE to respond to an incoming DICOM store, query or retrieve. The DICOM Server AE is always prepared to respond to a DICOM Store, Query, or Retrieve by any remote DICOM AE.

The DICOM Server AE will perform the Real-World activity *Image Installation* after the remote AE sends an image to the this AE.

Once a *Query* request is received, the CT DICOM Server AE will search the local database for all entries that match the keys requested by the Remote DICOM AE and send back the list of matches. The CT DICOM Server AE will also respond to an incoming retrieval request from a Remote AE by sending the image(s) to the Destination AE

2.2.1.2 PET Application Entity

The Basic and Specific Application models for the DICOM Query functionality, and the ability to Send/Receive/Query-Retrieve PET DICOM Images and Curves, Send/Receive/Query-Retrieve Secondary Capture DICOM Images, and Receive/Query-Retrieve CT and MR images by the PET DICOM Server AE are shown in the following Illustration:

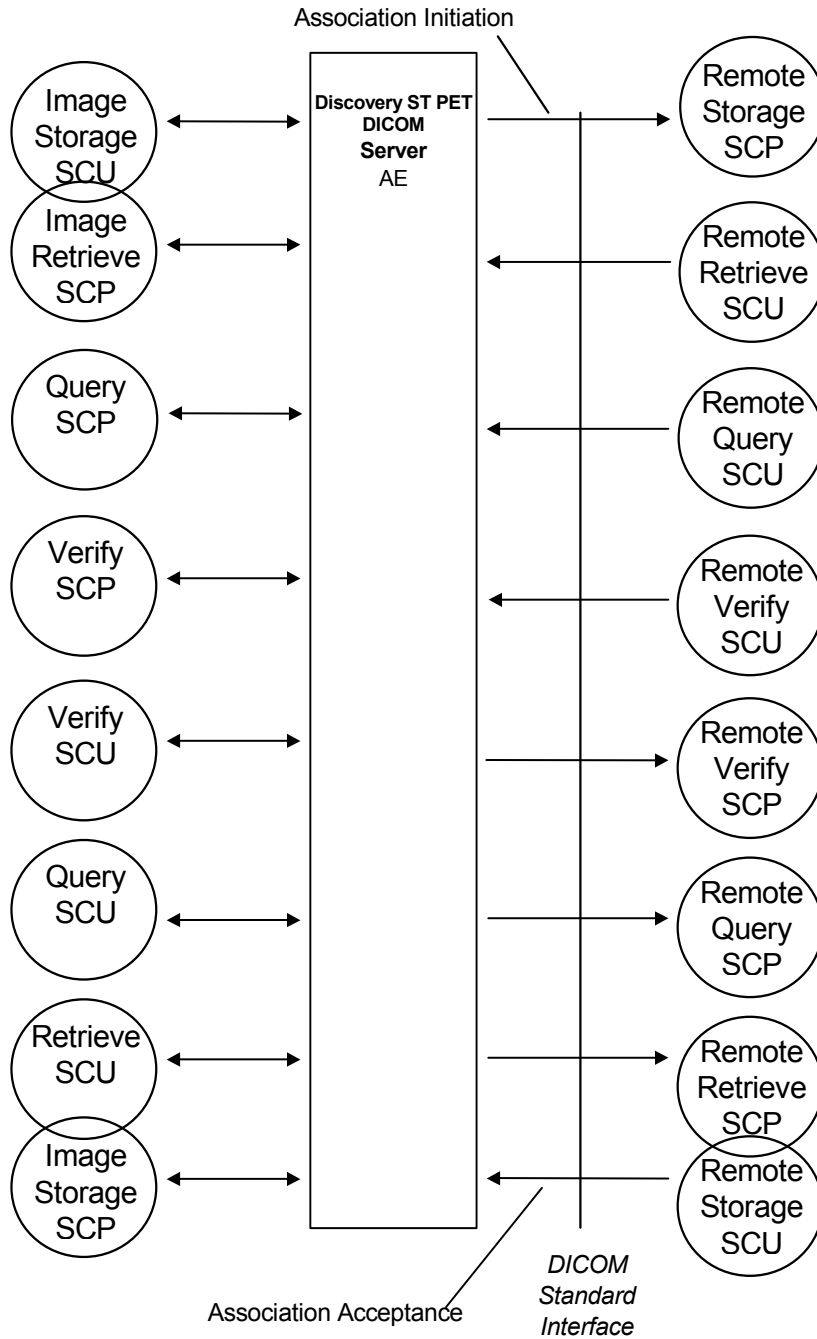

2.2.1.3 Xeleris Application Entity

The Basic and Specific Application models for Xeleris DICOM Server AE are shown in following illustration:

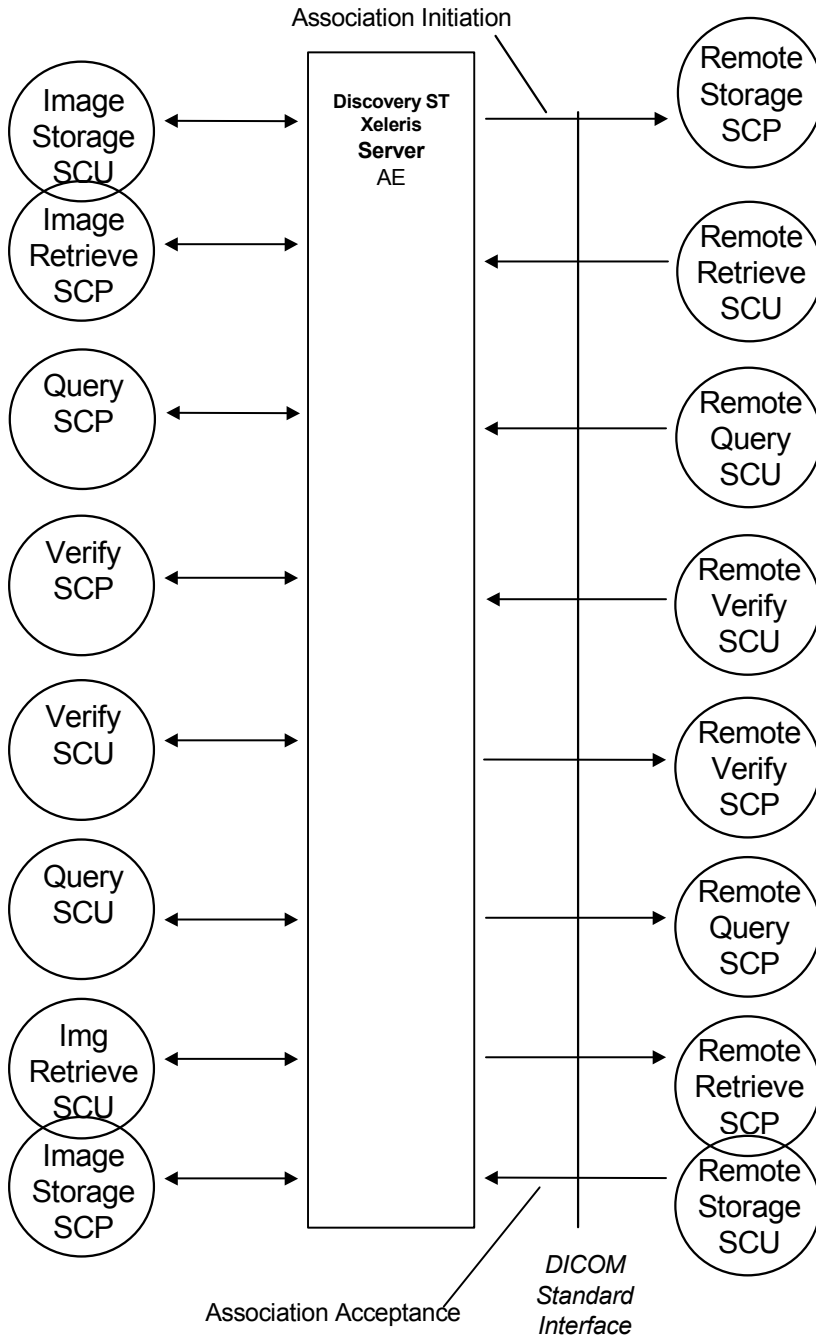

2.2.2 Functional Definition of AE's

The CT DICOM Server Application Entity initiates the following operations:

- *Ping DICOM Host(Verification)*: The CT DICOM Server initiates an association and sends a C-ECHO-RQ message to the remote DICOM AE, the remote DICOM Server will send back a C-ECHO-RSP message with a status of “success”.
- *Push*: Initiate an association to a Remote AE to send image(s). If the Remote AE accepts the presentation context applicable to the image(s) being sent, the CT DICOM Server AE will send the image(s) by invoking C-STORE-RQ operation for each image on the same association.
- *Query*: Initiate an association with a Remote AE to query for images on the remote host. A Study-Root Study-Level C-FIND-RQ request will be sent to the Remote AE once an association has been established. After all responses are received, CT DICOM Server AE will issue a Series-Level C-FIND-RQ request to get the series for a study in the list. An Image-Level C-FIND-RQ will be issued for the first series in the series list.
- *Get*: Send a C-MOVE-RQ request to a Remote AE after successful association establishment. The CT DICOM Server AE’s Storage SCP will receive the images over a separate association.

The **CT DICOM Server AE waits for association requests** from Remote AEs that wish to perform the following operations:

- *Verification*: If a C-ECHO-RQ message is received, the CT DICOM Server AE will send back a C-ECHO-RSP message with a status of “success”.
- *Image Storage*: If a C-STORE-RQ message is received, the CT DICOM Server AE will receive the image and try to update the local database. If the image is stored successfully on storage media and the database updated a status of “success” will be returned in a C-STORE-RSP message.
- *Query*: If a C-FIND-RQ message is received the CT DICOM Server AE will search the database for the requested attributes and send back a C-FIND-RSP message containing a match and a status of “pending”. After all matching records have been sent, a status of “success” will be returned in a C-FIND-RSP message. The Remote AE can terminate the query by sending a C-CANCEL-FIND-RQ message.
- *Retrieve*: If a C-MOVE-RQ message is received the CT DICOM Server AE will lookup its list of configured Remote AEs for the Destination AE. If the Destination AE is configured, the CT DICOM Server AE will open a new association to the Destination AE and use C-STORE-RQ to send the image(s). The CT DICOM Server AE will send a C-MOVE-RSP message with a status of “pending” after every five images are sent. When all images are sent or if CT DICOM Server AE receives a C-CANCEL-MOVE-RQ a final C-STORE-RSP will be sent back with an appropriate status.

The **PET DICOM Server AE initiates** the following functions:

Store: Initiates a DICOM association in order to send PET images and curves, and Secondary Capture images to a remote AE. If the remote AE accepts a presentation context applicable to the image(s), curve(s) being sent, the PET DICOM Server will send the images/curves data via the C-STORE service.

Verify: Initiates a DICOM association in order to send a verification message to a remote AE via a C-ECHO-RQ message.

Query: Initiates a DICOM association in order to query images on a remote AE. If the remote AE accepts a presentation context applicable to the query request(s) being sent, the PET DICOM Server will receive appropriate query responses via the C-FIND service.

Retrieve Initiates a DICOM association in order to fetch PET images/curves and Secondary Capture image data from a remote AE. If the remote AE accepts a presentation context applicable to the retrieve request(s), the remote AE initiates a C-STORE-RQ to the PET DICOM Server AE. If this is acceptable to the PET DICOM Server AE, then, the image(s)/curve(s) data is(are) sent to the PET DICOM Server AE.

Responds to DICOM associations transmitting CT or MR images to be stored.

The **PET DICOM Server AE responds** to the following functions:

Store: Responds to incoming C-STORE -RQ messages by storing the incoming PET images and curves, and Secondary Capture images, onto the disk.

Query: Responds to incoming C-FIND-RQ messages by searching its local database for the requested attributes and returning a C-FIND-RSP message containing a match and a status of “pending.” All other matches are also returned in C-FIND-RSP messages with status of “pending” until the last message which is returned with a status of “success.” The remote AE can terminate the query by sending a C-CANCEL-FIND-RQ message.

Retrieve: Responds to incoming C-MOVE-RQ messages by searching its local database for the requested PET image(s)/curve(s) and Secondary Capture image data and returning each via a C-STORE-RQ message. The PET DICOM Server will return a C-MOVE -RSP message after each image is sent. The status returned is “pending” until the last image is sent, in which case the appropriate status is returned. The remote AE can terminate the retrieve by sending a C-CANCEL-MOVE-RQ message.

Verify: Responds to incoming C-ECHO-RQ messages by returning a C-ECHO-RSP message with a status of “success.”

The **Xeleris DICOM Server Application Entity (AE) initiates** the following functions:

- *Store:* Initiates a DICOM association in order to send images to a remote AE. If the remote AE accepts a presentation context applicable to the image(s) being sent, the XELERIS DICOM Server will send the images via the C-STORE service.
- *Verify :* Initiates a DICOM association in order to send a verification message to a remote AE via a C-ECHO-RQ message.
- *Query:* Initiates a DICOM association in order to query images on a remote AE. If the remote AE accepts a presentation context applicable to the query request(s) being sent, the XELERIS DICOM Server will receive appropriate query responses via the C-FIND service.
- *Retrieve* Initiates a DICOM association in order to fetch images from a remote AE. If the remote AE accepts a presentation context applicable to the retrieve request(s), the remote AE initiates a DICOM association for C-STORE-RQ to the XELERIS DICOM Server AE. If this is acceptable to the XELERIS DICOM Server AE, then, the image(s) is(are) sent to the XELERIS DICOM Server AE.

The **Xeleris DICOM Server AE responds** to the following functions:

- *Store:* Responds to incoming C-STORE -RQ messages by storing the incoming data stream onto the disk.
- *Query:* Responds to incoming C-FIND-RQ messages by searching its local database for the requested attributes and returning a C-FIND-RSP message containing a match and a status of “pending.” All other matches are also returned in C-FIND-RSP messages with status of “pending” until the last message which is returned with a status of “success.” The remote AE can terminate the query by sending a C-CANCEL-FIND-RQ message.
- *Retrieve:* Responds to incoming C-MOVE-RQ messages by searching its local database for the requested image(s) and returning each via a C-STORE-RQ message. The XELERIS DICOM Server will return a C-MOVE -RSP message after each image is sent. The status returned is “pending” until the last image is sent, in which case the appropriate status is returned. The remote AE can terminate the retrieve by sending a C-CANCEL-MOVE-RQ message.

- *Verify* : Responds to incoming C-ECHO-RQ messages by returning a C-ECHO-RSP message with a status of "success."

2.2.3 Sequencing of Real-World Activities

Real-World Activity *Query Remote* must be performed before *Choose Get Option* can be performed.

2.2.4 CT Application Entity

2.2.4.1 AE SPECIFICATIONS

2.2.4.1.1 DICOM Server AE Specification

This Application Entity provides Standard Conformance to the following DICOM SOP Classes as an SCU:

SOP Class Name (SCU)	SOP Class UID
Verification (Echo)	1.2.840.10008.1.1
CT Image Information Storage	1.2.840.10008.5.1.4.1.1.2
MR Image Information Storage	1.2.840.10008.5.1.4.1.1.4
Secondary Capture Image Storage	1.2.840.10008.5.1.4.1.1.7
Study Root Query/Retrieve – FIND	1.2.840.10008.5.1.4.1.2.2.1
Study Root Query/Retrieve – MOVE	1.2.840.10008.5.1.4.1.2.2.2
Storage Commitment Push Model	1.2.840.10008.1.20.1

This Application Entity provides Standard Conformance to the following DICOM SOP classes as an SCP:

SOP Class Name (SCP)	SOP Class UID
Verification (Echo)	1.2.840.10008.1.1
CT Information Storage	1.2.840.10008.5.1.4.1.1.2
MR Information Storage	1.2.840.10008.5.1.4.1.1.4
Secondary Capture Image Storage	1.2.840.10008.5.1.4.1.1.7
Study Root Query/Retrieve – FIND	1.2.840.10008.5.1.4.1.2.2.1
Study Root Query/Retrieve – MOVE	1.2.840.10008.5.1.4.1.2.2.2

2.2.4.1.1.1 Association Establishment Policy

General

The DICOM Application Context Name (ACN), which is always proposed, is:

Application Context Name	1.2.840.10008.3.1.1.1
---------------------------------	------------------------------

The Maximum Length PDU negotiation is included in all association establishment requests. The maximum length PDU for association initiated by the DICOM Server AE is:

Maximum Length PDU	51 Kbytes
---------------------------	------------------

SOP class Extended Negotiation is not supported.

Maximum PDU Length of Zero (0) is not supported. The association request will be rejected when a request with “Maximum PDU length of zero” is received.

The maximum number of Presentation Context Items that is supported is 60. Note that the same Abstract Syntax may be offered multiple times with different Transfer Syntax.

The user information items sent by this product are:

- Maximum PDU Length and,
- Implementation UID

Number of Associations

The DICOM Server AE (SCU) will initiate only one DICOM association at a time to perform an image store to a remote host or retrieve image(s) from a Remote AE.

The DICOM Server AE (SCP) can have a maximum of four DICOM associations open simultaneously to receive and store image store or respond to an echo.

Asynchronous Nature

Asynchronous mode is not supported. All operations will be performed synchronously.

Implementation Identifying Information

The Implementation UID allows unique identification of a set of products that share the same implementation.

The Implementation UID for this ID/Net v3.0 Implementation is:

Discovery ST CT AE Implementation UID	1.2.840.113619.6.55
---------------------------------------	---------------------

2.2.4.1.1.2 Association Initiation by Real-World Activity

This AE attempts to initiate a new association due to a “ Ping DICOM Host” or “Push” operation initiated by the user. A new association is also initiated when the user performs a “Query Remote” operation or issues a retrieve operation by performing a “Get” operation at Study/Series/Image level.

Push Image(s) to Remote AE

Associated Real-World Activity

The operator must first select a destination by choosing “Select Remote Host” from the “Network” pull-down menu on the local database manager and then choose a hostname.

The “Push” operation will cause the DICOM server AE to initiate an Association when the operator selects one or more study, series, or images in the local database manager and then chooses either “Push Examination”, “Push Series”, or “Push Image” from the “Network” pull-down menu on the local database manager.

Note: If multiple study, series, or images are chosen to be pushed, one association will be established for each of the studies, series, or images.

Proposed Presentation Contexts

The following table shows the proposed presentation contexts for the DICOM Server AE after Real-World Activity “Push” Operation has been performed.

Table 2.2.1.2.1.2-1 Proposed Presentation Contexts for DICOM Server AE and Real-World activities Push, Query, Pull(Get Images) and Verification(Dicom Ping) SCUs

Presentation Context Table – Proposal					
Abstract Syntax		Transfer Syntax		Role	Extended Negotiation
Name	UID	Name List	UID List		
CT Image Storage	1.2.840.10008.5.1.4.1.1.2	Implicit VR Little Endian	1.2.840.10008.1.2	SCU	None
		Implicit VR Big Endian (GE Private)	1.2.840.113619.5.2		
		Explicit VR Little Endian	1.2.840.10008.1.2.1		
		Explicit VR Big Endian	1.2.840.10008.1.2.2		
MR Image Storage	1.2.840.10008.5.1.4.1.1.4	Implicit VR Little Endian	1.2.840.10008.1.2	SCU	None
		Implicit VR Big Endian (GE Private)	1.2.840.113619.5.2		
		Explicit VR Little Endian	1.2.840.10008.1.2.1		
		Explicit VR Big Endian	1.2.840.10008.1.2.2		
Secondary Capture Image Storage	1.2.840.10008.5.1.4.1.1.7	Implicit VR Little Endian	1.2.840.10008.1.2	SCU	None
		Implicit VR Big Endian (GE Private)	1.2.840.113619.5.2		
		Explicit VR Little Endian	1.2.840.10008.1.2.1		
		Explicit VR Big Endian	1.2.840.10008.1.2.2		
Study Root Query/Retrieve FIND	1.2.840.10008.5.1.4.1.2.2.1	Implicit VR Little Endian	1.2.840.10008.1.2	SCU	None
Study Root Query/Retrieve MOVE	1.2.840.10008.5.1.4.1.2.2.2	Implicit VR Little Endian	1.2.840.10008.1.2	SCU	None
Verification	1.2.840.10008.1.1	Implicit VR Little Endian	1.2.840.10008.1.2	SCU	None

Note: Other Abstract Syntax and Transfer Syntax names may be offered when establishing an association. These are private syntax which may be ignored. See section 2.2.4.3.

This implementation can perform multiple C-STORE operations over a single association.

Upon receiving a C-STORE confirmation containing a successful status, this implementation will perform the next C-STORE operation. The association will be maintained if possible.

Upon receiving a C-STORE confirmation containing a Refused status, this implementation will terminate the association.

Upon receiving a C-STORE confirmation containing any status that is not Success or Refused, this implementation will consider the current request to be a failure but will continue to attempt to send the remaining images in the request on the same association.

Each C-STORE operation supports an "Association Timer". This timer starts when the association request is sent or received and stops when the association is established. The time-out is 900 seconds.

Each C-STORE operation also supports an "Operation Inactivity Timer". This time-out starts once the first C-STORE request has been issued (on association) or received and is reset each time a C-STORE response has been received or when subsequent C-STORES are sent. This time-out is 900 seconds.

Each C-STORE operation also supports a "Session Timer". This timer starts when the association is established and stops when the association is ended. This time-out is 60 minutes.

If any of the three timers mentioned above expires, the connection is closed and the operation in progress is considered failed.

Note: The time-outs are configurable.

When DICOM Server AE initiates an association to issue a C-STORE, one of the following two operations will be performed.

1. If the image is stored locally on the Discovery ST in DICOM format ("DICM" appears in the "Fmt" column at the exam level of the local database manager), the image will be transmitted by the DICOM Server AE with the same elements as was originally received or created locally (for the standard elements only).
2. If the image is stored locally on the Discovery ST in a non-DICOM Advantage format ("Adv" appears in the "Fmt" field at the exam level of the local database manager), the image will be translated and then transmitted by the DICOM Server AE to the identical profiles specified by the CT Advantage Conformance Statement for DICOM (Direction 2118781) and the MR Signa Advantage Conformance Statement for DICOM (Direction 2118782).

Query Remote AE

Associated Real-World Activity

The operator must first select a destination by choosing "Select Remote Host" from "Network" pull-down menu on the local database manager and then choose a hostname. To do custom queries select "Yes" for "**Custom search**" option.

Note:

Custom queries can be done on the following fields "Last Name contains", "Exam Number", "Patient Id", "Accession Number".

To initiate a Query select "**Receive**" from "**Network**" pull-down menu.

Note:

If “Custom Search” option is set then a small GUI will show up. Operator will be able to enter custom query fields. Entering values in “Last Name contains” field will initiate wild card query for patient name.

The “Query” operation will cause the DICOM Server AE to initiate an association to the selected Remote AE when the “Query Remote Host” entry is selected from the “Network” pull-down menu. Once a list of Study/Series/Image is retrieved, the operator can invoke the “Get” operation by choosing “Get Exam” or “Get Series” or “Get Image” from the “Network” pull-down menu.

Proposed Presentation Contexts

When the Real-World activity “Query” or “Get” is initiated all presentation contexts shown in table 2.2.1.2.1.2-1 are proposed during association establishment, but only the Query/Retrieve-FIND related contexts are applicable to this activity.

SOP Specific Conformance Statement for C-FIND SCU

After the Query operation is initiated, the DICOM Server AE will perform a study-root C-FIND-RQ request at each of the three levels (Study, Series, and Image) in succession. The Initial Study-Level request will ask for all studies in the Remote database.

The C-FIND SCU will not perform any extended negotiation and so will only perform hierarchical query. Relational Queries are not supported.

Each C-FIND SCU operation supports an “Association Timer”, “Operation Inactivity Timer” and “Session Timer” with time out values of 900 seconds, 900 seconds and 60 minutes respectively.

If a “Cancel” or “Refused” status is returned from the Remote AE the association is closed and the operation terminated.

The DICOM Server AE will parse each matching C-FIND-RSP reply and ignore the entries it fails to parse. Tables 2.3.1.2.2.2.1-1 - 2.3.1.2.2.2.1-3 shows the various fields that are requested at the Study, Series, and Image levels of the C-FIND request.

Query results are filtered based on the Modality field. Only CT/MR images are supported.

Note: In the following tables the Type field has the following meaning:

R - Required **U** - Unique **O** - Optional **P** - Private

Table 2.3.1.2.2.2.1-1: Requested Study Level Keys

Description	Type	Tag	Value
Study date	R	0008,0020	Zero length
Study time	R	0008,0030	Zero length
Accession number	R	0008,0050	Zero length, or value specified in custom query
Patient’s name	R	0010,0010	Zero length, or value specified in custom query
Patient id	R	0010,0020	Zero length, or value specified in custom query
Study id	R	0020,0010	Zero length, or value specified in custom query

Description	Type	Tag	Value
Study Instance UID	U	0020,000D	Zero length
Study description	O	0008,1030	Zero length
Private Creator Identification	P	0009,00xx	GEMS_IDEN_01
Suite Id	P	0009,xx02	Zero Length

Table 2.3.1.2.2.2.1-2: Requested Series Level Keys

Description	Type	Tag	Value
Study Instance UID	U	0020,000D	Study Instance UID from Study level query response
Modality	R	0008,0060	Zero length
Series number	R	0020,0011	Zero length
Series Instance UID	U	0020,000E	Zero length
Series description	O	0008,103E	Zero length
Manufacturer	O	0008,0070	Zero length
Images in series	O	0020,1002	Zero length

Table 2.3.1.2.2.2.1-3: Requested Image Level Keys -

Description	Type	Tag	Value
Study Instance UID	U	0020,000D	Study Instance UID from Study level query response
Series Instance UID	U	0020,000E	Series Instance UID from Series level query response
Instance number	R	0020,0013	Zero length
SOP Instance UID	U	0008,0018	Zero length
Image type	O	0008,0008	Zero length
Rows	O	0028,0010	Zero length
Columns	O	0028,0011	Zero length
Image position	O	0020,0032	Zero length
Image orientation	O	0020,0037	Zero length
Slice thickness	O	0018,0050	Zero length
Slice spacing	O	0018,0088	Zero length
Gantry tilt	O	0018,1120	Zero length
Convolution kernel	O	0018,1210	Zero length
Reconstruction diameter	O	0018,1100	Zero length
Data collection diameter	O	0018,0090	Zero length
Flip angle	O	0018,1314	Zero length
Echo number	O	0018,0086	Zero length
Echo time	O	0018,0081	Zero length
Inversion time	O	0018,0082	Zero length
Repetition time	O	0018,0080	Zero length
Trigger time	O	0018,1060	Zero length
Private Creator Identification	P	0019,00xx	GEMS_ACQU_01
Dfov Rect	P	0019,xx1E	Zero Length
Midscan Time	P	0019,xx24	Zero Length
Azimuth	P	0019,xx26	Zero Length
Number of Echo	P	0019,xx7E	Zero Length
Private Creator Identification	P	0021,00xx	GEMS_REL_01

Description	Type	Tag	Value
Scout Anref	P	0021,xx4A	Zero Length
Private Creator Identification	P	0027,00xx	GEMS_IMAG_01
Location RAS	P	0027,xx40	Zero Length
Location	P	0027,xx41	Zero Length
Center R Coordinate	P	0027,xx42	Zero Length
Center A Coordinate	P	0027,xx43	Zero Length
Table Start Location	P	0027,xx50	Zero Length
Table End Location	P	0027,xx51	Zero Length
RAS Letter for Side of Image	P	0027,xx52	Zero Length
RAS Letter for Anterior/Posterior	P	0027,xx53	Zero Length
RAS Letter for Scout Start Location	P	0027,xx54	Zero Length
RAS Letter for Scout End Location	P	0027,xx55	Zero Length
Image Dimension X	P	0027,xx60	Zero Length
Image Dimension Y	P	0027,xx61	Zero Length

Get Image(s) from Remote AE

Associated Real-World Activity

The operator must first select a destination by choosing “*Select Remote Host*” from “*Network*” pull-down menu on the local database manager and then choose a hostname. The operator then has to perform the Real-World activity “*Query*” to get a list of Study/Series/Image. Once the list of Study/Series/Image is retrieved, the operator can invoke the “*Get*” operation by choosing “*Get Exam*” or “*Get Series*” or “*Get Image*” from the “*Network*” pull-down menu.

Proposed Presentation Contexts

When the Real-World activity “*Get*” is initiated all presentation contexts shown in table 2.2.1.2.1.2-1 are proposed during association establishment, but only the Query/Retrieve-MOVE related contexts are applicable to this activity.

SOP Specific Conformance Statement for C-MOVE SCU

When the operator starts a *Get* operation at any level (Study, Series, Image) the DICOM Server AE will initiate a C-MOVE-RQ request to the Remote AE with the DICOM Server AE as the Destination AE. The Storage SCP will handle the incoming images as described in section 2.2.1.3.1.

Each C-MOVE SCU operation supports an “*Association Timer*”, “*Operation Inactivity Timer*” and “*Session Timer*” with time out values of 900 seconds, 300 seconds and 60 minutes respectively.

The DICOM Server AE will send a C-CANCEL-MOVE-RQ to the Remote AE if the operator “*Pauses*” or “*Clears*” the job from the local database manager Network queue.

Real-World Activity: Verify (DICOM Ping)

Associated Real-World Activity

The operator must first select a destination by choosing “*Select Remote Host*” from “*Network*” pull-down menu on the local database manager and then choose a hostname.

The operator must then select the “*Ping DICOM host*” form “*Network*” pull-down menu.

The DICOM server will initiate an association with the remote DICOM AE in order to verify communication at the application level. The success or failure of the verification process is displayed to the user.

Proposed Presentation Context Table

Refer to the Table 2.2.1.2.1.2-1 for the Proposed Presentation Contexts for DICOM Server AE and Real-World activity Verification

SOP Specific DICOM Conformance C_ECHO SCU

The Discovery ST DICOM Server AE provides standard conformance to the DICOM Verification Service Class.

Each ECHO operation supports an “Association Timer”, “Operation Inactivity Timer” and “Session Timer” with a time out values of 900 seconds, 30 seconds and 60 minutes respectively

Real-World Activity: Storage Commitment -

Associated Real-World Activity

The operator must first select a destination by choosing “*Select Remote Host*” from “*Network*” pull-down menu on the local database manager and then choose a hostname. Select the “*Update*” option, if the hostname is already present. Set the “*Archive Node*” option to “*Yes*”. If the remote host is not present add the remote host in the local database with “*Archive Node*” option set to “*Yes*”.

Note :

The remote node should be a Storage Commitment SCP.

The operator must then select “*Archive*” pull-down menu on the local database manager. Select “*Select Media*” option menu. Select “*Remote Node*” in the menu.

Note :

The remote node option on the archive menu will be present only if a remote node is configured as an archive node.

The operator then selects one or more study, series, or images in the local database manager and then chooses either “*Save Examination*”, “*Save Series*”, or “*Save Image*” from the “*Archive*” pull-down menu on the local database manager.

Note:

Also refer to section 5.3.1.3

Proposed Presentation Context Table

Refer to section 5.3.1.4

Refer to section 5.3.1.4

2.2.4.1.1.3 Association Acceptance Policy

The DICOM Server AE places limitations on who may connect to it .

If the Remote AE needs to “Push Images” or “Query/Retrieve Images”, to the local system then it has to be configured in the Local system to do the same.

To configure a remote AE choose “Select Remote Host” in the “network” pull down menu. Select the Remote Host and choose “Update” option, if the Remote AE is already present. If the Remote AE is not present choose “Add” option to add the Remote AE.

Set “Push Images” option to “Yes” , if the Remote AE needs to push images to the Local system

Set “Query/Retrieve” option to “Yes”, if the Remote AE needs to “Query/Retrieve” the local system.

When the DICOM Server AE accepts an association for image storage, it will receive any images transmitted on that association and store the images on disk.

It will also respond to queries from Remote AEs by sending matching entries. Any Remote AE can request and receive a list of images on the local database. The Remote AE must be configured in the local database manager’s list of Remote AE for it to be able to retrieve images from DICOM Server AE.

Any remote AE can open an association to the DICOM Server AE for the purpose of verification.

Receive Image(s)

This AE is indefinitely listening for associations. No operator action is required to receive an image.

Associated Real-World Activity

The Real-World Activity associated with the Receive Image(s) operation is the storage of the image on the disk drive of the Discovery ST.

Presentation Context Table

Table 2.2.1.3.1.2-1: Accepted Presentation Contexts for DICOM Server AE and Real-World Activity Receive Image(s)

Presentation Context Table - Accepted

Abstract Syntax		Transfer Syntax		Role	Extended Negotiation
Name	UID	Name List	UID List		
Verification	1.2.840.10008.1.1	Implicit VR Little Endian	1.2.840.10008.1.2	SCP	None
CT Image Storage	1.2.840.10008.5.1.4.1.1.2	Implicit VR Little Endian Implicit VR Big Endian (GE Private) Explicit VR Little Endian Explicit VR Big Endian	1.2.840.10008.1.2 1.2.840.113619.5.2 1.2.840.10008.1.2.1 1.2.840.10008.1.2.2	SCP	None
MR Image Storage	1.2.840.10008.5.1.4.1.1.4	Implicit VR Little Endian Implicit VR Big Endian (GE Private) Explicit VR Little Endian Explicit VR Big Endian	1.2.840.10008.1.2 1.2.840.113619.5.2 1.2.840.10008.1.2.1 1.2.840.10008.1.2.2	SCP	None
Secondary Capture Image Storage	1.2.840.10008.5.1.4.1.1.7	Implicit VR Little Endian Implicit VR Big Endian (GE Private) Explicit VR Little Endian Explicit VR Big Endian	1.2.840.10008.1.2 1.2.840.113619.5.2 1.2.840.10008.1.2.1 1.2.840.10008.1.2.2	SCP	None

Note: The SCP does not have a default acceptance policy if more than one acceptable transfer syntax is proposed by the SCU. It is the responsibility of the SCU to make a selection from more than one transfer sentences accepted.

SOP Specific Conformance to C_STORE SCP

The DICOM Server AE conforms to the SOP's of the Storage Service Class at level 1 (base). Private elements will be discarded from the image when receiving images containing non-GE private data elements. All of the **standard** type elements (1,1c,2,2c,3) will be retained.

Each C-STORE SCP operation supports an "Association Timer", "Operation Inactivity Timer" and "Session Timer" with time out values of 900 seconds, 900 seconds and 60 minutes respectively.

Image Reception

If the DICOM Server AE returns one of the following status codes, then the C-STORE operation was unsuccessful and no image will be installed:

- 0110 (Processing Failure) indicates that an internal system call has failed while processing an image.

- A711 (Out of Resources) Indicates that probably there was not enough disk space to store the image. The user should attempt recovery by removing some images from the Discovery ST system.
- A712 (Out of Resources) indicates that there was not enough resource (such as memory) to store the image.
- A800 (SOP Class not supported)

In the event of a successful C-STORE operation, the image has successfully been written to disk. The image will then be accessed in the same manner as any other image by the applications on the Discovery ST system.

Images may be deleted when instructed to do so by the user. Thus the duration of the storage of the image is determined by the users of the Discovery ST system.

Image Installation

If the image installation is unsuccessful, a message will appear in the Message Log informing the user of the failure and the image will be removed.

If the image installation process finds that an element is not encoded according to the DICOM standard, it will fail to install the image and the file will be removed.

Image Installation of GE Created MR or CT Images

Images that were originally created on recent GE MR and CT scanners will be converted from their native Advantage Proprietary Format to DICOM format for transmission. If the images are stored as full fidelity representations and are subsequently returned to recent GE scanners, then the images will be transformed back to Advantage Proprietary Format.

There is an assumption made by such GE scanners:

The private element (0009,xx01) is used as the full fidelity flag. If this flag contains the string: "GE_GENESIS_FF" when received by a scanner, then it is assumed that the image object was originally a GE created image object and contains all private elements that it was sent with.

If full fidelity flag is present and not all the elements are sent back as sent (i.e., not full fidelity) there are 2 possible actions:

1. the translator will do its best to convert the image and will use default values where DICOM fields are missing
2. If certain critical information is not provided then the image will be stored as a Secondary Capture

It is strongly suggested that if GE private element (0009,xx01) is present then all GE private elements originally associated with the image be preserved.

Note :

The images created on Discovery ST system will be stored as DICOM images with GE Big Endian (Private transfer syntax) on the system.

The private element (0009,xx01) will have the value “CT_LIGHTSPEED”.

Image Installation of non-GE Created MR or CT Images

Images received from non-GE products are installed as appropriate image object without any of their private data elements. Also if some critical fields (mandatory) are missing, then the image will not be installed.

Verification Request from Remote AE

This AE is indefinitely listening for associations. No operator action is required to respond to a *verification* message.

Associated Real-World Activity

The Real-World Activity associated with the verification request is to send a C-ECHO response message with a status of “success” to the requesting AE.

Presentation Context Table

Table 2.2.1.3.2.2-1: Acceptable Presentation Contexts for DICOM Server AE and Real-World Activity Verification Request

Presentation Context Table					
Abstract Syntax		Transfer Syntax		Role	Extended Negotiation
Name	UID	Name List	UID List		
Verification	1.2.840.10008.1.1	Implicit VR Little Endian	1.2.840.10008.1.2	SCP	None

SOP Specific Conformance to C_ECHO SCP

The DICOM Server AE provides standard conformance to the DICOM Verification Service Class.

Each ECHO operation supports an “Association Timer”, “Operation Inactivity Timer” and “Session Timer” with a time out values of 900 seconds, 30 seconds and 60 minutes respectively.

Query Request from Remote AE

This AE is indefinitely listening for associations. No operator action is required to respond to a *query* request.

Associated Real-World Activity

The Real-World Activity associated with the query request is to search the local database for entries that match the request and send a C-FIND response message with a status of “pending” for each matching entry.

Presentation Context Table

Table 2.2.1.3.1.2-1: Acceptable Presentation Contexts for DICOM Server AE and Real-World Activity Query Request

Presentation Context Table					
Abstract Syntax		Transfer Syntax		Role	Extended Negotiation
Name	UID	Name List	UID List		
Study Root Query/Retrieve FIND	1.2.840.10008.5.1.4.1.2.2.1	Implicit VR Little Endian	1.2.840.10008.1.2	SCP	None

SOP Specific Conformance to C-FIND SCP

Each C-FIND SCP operation supports an “Association Timer”, “Operation Inactivity Timer” and “Session Timer” with a time out values of 900 seconds, 900 seconds and 60 minutes respectively.

All Required(R) and Unique(U) study, series, and image level keys for the Study-Root Query/Retrieve information model are supported. Some optional (O) keys are also supported as described in the following tables.

Note: In the following tables the type field has the following meaning:
R - Required U - Unique O - Optional P - Private

Table 2.3.1.3.3.2.1-1 Supported study level keys

Description	Type	Tag	Usage
Study date	R	0008,0020	Matched
Study time	R	0008,0030	Matched
Accession number	R	0008,0050	Matched
Patient’s name	R	0010,0010	Matched
Patient id	R	0010,0020	Matched
Study id	R	0020,0010	Matched
Study Instance UID	U	0020,000D	Matched
Study description	O	0008,1030	Returned
Suite Id	P	0009,0002	Returned

Table 2.3.1.3.3.2.1-2 Supported series level keys

Description	Type	Tag	Usage
Modality	R	0008,0060	Matched
Series number	R	0020,0011	Matched
Series Instance UID	U	0020,000E	Matched
Series description	O	0008,103E	Returned

Description	Type	Tag	Usage
Manufacturer	O	0008,0070	Returned
Images in series	O	0020,1002	Returned

Table 2.3.1.3.3.2.1-3 Supported image level keys

Description	Type	Tag	Usage
Instance number	R	0020,0013	Matched
SOP Instance UID	U	0008,0018	Matched
Image type	O	0008,0008	Returned
Rows	O	0028,0010	Returned
Columns	O	0028,0011	Returned
Image position	O	0020,0032	Returned
Image orientation	O	0020,0037	Returned
Slice thickness	O	0018,0050	Returned
Slice spacing	O	0018,0088	Returned
Gantry tilt	O	0018,1120	Returned
Convolution kernel	O	0018,1210	Returned
Reconstruction diameter	O	0018,1100	Returned
Data collection diameter	O	0018,0090	Returned
Flip angle	O	0018,1314	Returned
Echo number	O	0018,0086	Returned
Echo time	O	0018,0081	Returned
Inversion time	O	0018,0082	Returned
Repetition time	O	0018,0080	Returned
Trigger time	O	0018,1060	Returned
Dfov Rect	P	0019,001E	Returned
Midscan Time	P	0019,0024	Returned
Azimuth	P	0019,0026	Returned
Number of Echo	P	0019,007E	Returned
Scout Anref	P	0021,004A	Returned
Location RAS	P	0027,0040	Returned
Location	P	0027,0041	Returned
Center R Coordinate	P	0027,0042	Returned
Center A Coordinate	P	0027,0043	Returned
Table Start Location	P	0027,0050	Returned
Table End Location	P	0027,0051	Returned
RAS Letter for Side of Image	P	0027,0052	Returned
RAS Letter for Anterior/Posterior	P	0027,0053	Returned
RAS Letter for Scout Start Location	P	0027,0054	Returned
RAS Letter for Scout End Location	P	0027,0055	Returned
Image Dimension X	P	0027,0060	Returned
Image Dimension Y	P	0027,0061	Returned

Note: In the above tables the type field has the following meaning:
R - Required **U** - Unique **O** - Optional **P** - Private

Only keys with Usage type *Matched* will be matched against values in the database.

Values in keys of type *Returned* will be ignored and will be filled in with data from the database.

If an optional key is requested that does not appear in any of the tables above, that key will be ignored and no corresponding element will be returned.

If the database does not have a value corresponding to any requested optional key a zero-length element will be returned.

Sequence matching is not supported.

Range matching is supported for attributes of type date and time.

Only hierarchical query is supported.

Retrieve Request From Remote AE

This AE is indefinitely listening for associations. No operator action is required to respond to a *retrieve* request.

Associated Real-World Activity

The Real-World Activity associated with the Retrieve Request is to send all images corresponding to the C-MOVE request to the destination AE through a separate association.

Presentation Context Table

Table 2.2.1.3.4.2-1: Acceptable Presentation Contexts for DICOM Server AE and Real-World Activity Retrieve Request.

Presentation Context Table					
Abstract Syntax		Transfer Syntax		Role	Extended Negotiation
Name	UID	Name List	UID List		
Study Root Query/Retrieve MOVE	1.2.840.10008.5.1.4.1.2.2.2	Implicit VR Little Endian	1.2.840.10008.1.2	SCP	None

SOP Specific Conformance to C-MOVE SCP

The DICOM Server AE provides standard conformance to the baseline Study-root C-MOVE Service Class SCP.

Each C-MOVE SCP operation supports an “Association Timer”, “Operation Inactivity Timer” and “Session Timer” with a time out values of 900 seconds, 300 seconds and 60 minutes respectively. These time-outs are configurable in dcs.cfg as *bi_assoc_tio*, *bi_store_tio* and *bi_session_tio* respectively.

All images requested in a C-MOVE-RQ will be sent over a single association. A C-MOVE-RSP with a “pending” status will be returned to the requester every five images.

The C-MOVE SCP will invoke C-STORE requests for the following SOP classes:

SOP Class Name	SOP Class UID
CT Image Information Storage	1.2.840.10008.5.1.4.1.1.2
MR Image Information Storage	1.2.840.10008.5.1.4.1.1.4
Secondary Capture image storage	1.2.840.10008.5.1.4.1.1.7

In addition to the C-MOVE response status values defined in DICOM part 4 the following status values will be returned:

- C000 - Indicates that an error occurred while retrieving records from the local database.
- C001 - Indicates all other processing error.
- C011 - If the Destination AE returns a “Storage Full” condition this status will be returned. This status will only be sent if the Destination AE returns a status of A711 and is only applicable if the Destination AE is another GE Medical Systems product.

Presentation Context Acceptance Criteria

No criterion.

Transfer Syntax Selection Policy

All protocols detailed above in the tables are supported, no priority selection is given.

2.2.4.2 COMMUNICATION PROFILES

2.2.4.2.1 Supported Communication Stacks (parts 8,9)

DICOM Upper Layer (Part 8) is supported using TCP/IP.

2.2.4.2.2 TCP/IP Stack

The TCP/IP stack is inherited from a UNIX Operating System.

2.2.4.2.2.1 Physical Media Support

Ethernet v2.0, IEEE 802.3. Auto senses 10/100 Base T Ethernet connection.

2.2.4.2.3 Point-to-Point Stack

A 50-pin ACR-NEMA connection is not applicable to this product.

2.2.4.3 EXTENSIONS / SPECIALIZATIONS / PRIVATIZATIONS – CT Application Entity

2.2.4.3.1 Specialized Information Object Definition

Following is a list of additional private attributes defined for a standard **CT IOD**.

(0008,0008) Value 3: CT Image IOD specific specializations
AXIAL
LOCALIZER
SEGMENTED
REFORMATTED
PROCESSED
COMBINED

Value 4 : CT Image implementation specific
MIN IP
MIP
AVERAGE
VOLREN
INTEGRAL
HD MIP
RAYSUM
SURFACE
MINMAX

(0018,0022) Scan Options : Defined Terms
AXIAL MODE
DYNAMIC MODE
SCOUT MODE
AXIAL MODE
STATIC XRON MODE
STATIC XROFF MODE
TUBE HEAT MODE
DAS MODE
TUBE CAL MODE
BIOPSY MODE
CINE
HELICAL
ROTGENCAL MODE

2.2.4.3.2 Private SOP's

ID/Net v2.0 Private IOD's are based upon the April 1993 draft version of the DICOM. ID/Net v2.0 IOD's are supported for backward compatibility.

Note: See the “ID/Net v2.0 Implementation Profiles” (Direction 46-269546G2) for definitions of Information Objects.

Presentation Context Table - Accepted / Proposed					
Abstract Syntax		Transfer Syntax		Role	Extended Negotiation
Name	UID	Name List	UID List		
GE Private DICOM MR Image Information Object (ID/Net v2.0 compatible)	1.2.840.113619.4.2	Implicit VR Little Endian	1.2.840.10008.1.2	Both	None
GE Private DICOM MR Image Information Object (ID/Net v2.0 compatible)	1.2.840.113619.4.2	Implicit VR Big Endian (GE Private)	1.2.840.113619.5.2	Both	None
GE Private DICOM CT Image Information Object (ID/Net v2.0 compatible)	1.2.840.113619.4.3	Implicit VR Little Endian	1.2.840.10008.1.2	Both	None
GE Private DICOM CT Image Information Object (ID/Net v2.0 compatible)	1.2.840.113619.4.3	Implicit VR Big Endian (GE Private)	1.2.840.113619.5.2	Both	None
GE Private DICOM Display Information Object (ID/Net v2.0 compatible)	1.2.840.113619.4.4	Implicit VR Little Endian	1.2.840.10008.1.2	Both	None
GE Private DICOM Display Information Object (ID/Net v2.0 compatible)	1.2.840.113619.4.4	Implicit VR Big Endian (GE Private)	1.2.840.113619.5.2	Both	None

2.2.4.3.3 Private Data Elements

Refer to **Appendix B** for a complete listing of private data elements used with this implementation.

2.2.4.4 CONFIGURATION

2.2.4.4.1 AE Title/Presentation Address Mapping

The Discovery ST system allows the user to “add”, “Remove”, or “Update the mapping of remote AE Titles to IP Addresses and Ports. These options can be selected from the “Remote Host Selection” menu displayed by choosing “Select

Remote Host” from the “Network” pull-down menu from the local database manager.

2.2.4.4.2 Configurable Parameters

The following fields are configurable for the DICOM Server AE:

- Local AE Title (the machine hostname)
- Local IP Address
- Local IP Netmask
- Max PDU length
- Time-outs, which are set for all hosts, are configurable in dcs.cfg:
 - *Association time-out - *bi_assoc_tio*
 - *Session timeout - *bi_session_tio*
 - *Create timeout - *bi_ncreate_tio*

Note: All configurations should be performed by a GE Field Service Engineer.

Note: The local port on which the Discovery ST CT system receives DICOM incoming TCP connections is port **4006**.

2.2.4.5 SUPPORT OF EXTENDED CHARACTER SETS

In addition to the DICOM default character set, *Discovery ST* supports the ISO IR 100 Latin alphabet #1 supplementary set for the purpose of interchange.

2.2.5 PET Application Entity

2.2.5.1 AE SPECIFICATIONS - PET Application Entity

This Application Entity provides Standard Conformance to the following DICOM SOP Classes as an SCU:

SOP Class Name	SOP Class UID
PET Image Storage	1.2.840.10008.5.1.4.1.1.128
PET Curve Storage	1.2.840.10008.5.1.4.1.1.129
Standalone Curve Storage	1.2.840.10008.5.1.4.1.1.9
GE Private PET RAW data storage	1.2.840.113619.4.30
Secondary Capture Storage	1.2.840.10008.5.1.4.1.1.7
Study Root Query/Retrieve Information Model - FIND	1.2.840.10008.5.1.4.1.2.2.1
Study Root Query/Retrieve Information Model - MOVE	1.2.840.10008.5.1.4.1.2.2.2
Verification SOP Class – ECHO	1.2.840.10008.1.1

This Application Entity provides Standard Conformance to the following DICOM SOP Classes as an SCP:

SOP Class Name	SOP Class UID
PET Image Storage	1.2.840.10008.5.1.4.1.1.128
PET Curve Storage	1.2.840.10008.5.1.4.1.1.129
Standalone Curve Storage	1.2.840.10008.5.1.4.1.1.9
GE Private PET RAW data storage	1.2.840.113619.4.30
Secondary Capture Storage	1.2.840.10008.5.1.4.1.1.7
CT Image Image Storage	1.2.840.10008.5.1.4.1.1.2
MR Image Image Storage	1.2.840.10008.5.1.4.1.1.4
Patient Root Query/Retrieve Information Model - FIND	1.2.840.10008.5.1.4.1.2.1.1
Patient Root Query/Retrieve Information Model - MOVE	1.2.840.10008.5.1.4.1.2.1.2
Study Root Query/Retrieve Information Model - FIND	1.2.840.10008.5.1.4.1.2.2.1
Study Root Query/Retrieve Information Model - MOVE	1.2.840.10008.5.1.4.1.2.2.2
Verification SOP Class	1.2.840.10008.1.1

2.2.5.1.1.1 Association Establishment Policies - PET Application Entity

General

The DICOM Application Context Name (ACN) for PET DICOM Server AE , which is always proposed, is:

Application Context Name	1.2.840.10008.3.1.1.1
---------------------------------	------------------------------

The Maximum Length PDU negotiation is included in all association establishment requests is:

Maximum Length PDU for SCU role	64 Kbytes
--	------------------

Note- The PET DICOM Server AE does not support a PDU length of zero.

The SOP Class Extended Negotiation is not supported.

The maximum number of Presentation Context Items that will be proposed is 8. Note that the same Abstract Syntax may be offered multiple times with different Transfer Syntaxes.

The user information Items sent by this product are :

- Maximum PDU Length
- Implementation UID
- Implementation Version Name

Number of Associations

The PET DICOM Server AE (SCU) will initiate only one DICOM association at a time to perform an image store to a single remote AE. Only one association can be open at any point of time in order to perform Send, Query and Retrieve operations. However, if AutoTransfer option is enabled on the PET UI, an additional association will be established and this could co-exist with any association initiated by the user manually from PET network UI.

The PET DICOM Server AE (SCP) can have a maximum of eight DICOM associations open simultaneously to service queries, retrieves or verifications.

Asynchronous Nature

Asynchronous mode is not supported. All operations will be performed synchronously.

Implementation Identifying Information - PET Application Entity

The Implementation UID for this DICOM Implementation is:

Discovery ST PET AE Implementation UID	1.2.840.113619.6.131
---	-----------------------------

The Implementation Version Name for this DICOM Implementation is:

Discovery ST PET AE Implementation Version Name	"GE Discovery ST"
--	--------------------------

2.2.5.1.1.2 Association Initiation Policy - PET Application Entity

The PET DICOM Server AE initiates a new association:

- Due to an image send operation being initiated from the Discovery ST Network Operations User interface
- Due to a Verify operation initiated to determine whether the remote DICOM station is operational.
- Due to image data being Queried from a Remote AE, where the query operation is initiated from the Discovery ST Network Operations User interface.
- Due to image data being Retrieved from a Remote AE, where the retrieve operation is initiated from the Discovery ST Network Operations User interface.

Real-World Activity : Send/Image Store - PET Application Entity

Associated Real-World Activity

The operator must select the image type of data to be included for the transfer data to be transferred from the Patient Listing, and select a destination from the Network Operations User Interface. Once these selections have been made, the operator pushes the "Transfer" button to initiate a Send operation. The PET DICOM Server AE will then initiate an association with the remote AE in order to send the selected data.

Note that for each send operation, typically one association is established. The exception to this is that, if a send fails, the current association may be closed and another is opened for sending the remaining data (image(s)/curve(s) data).

The "Transfer In Progress Window" (TIPW) and the Transfer Status textual string on the bottom left hand corner of the Network Operations User Interface in association with the Transfer Log indicates the status of the data being transferred. The associated error messages due to a failed operation can be one of the following. The Discovery ST Error Log utility provides more detailed information regarding the cause of the error. -

- "%s - Transfer completed"
- "%s - Error during transfer"
- "%s - Transfer completed with errors"

- "DICOM Transfer operation has been canceled"
- Error while initializing DCM...
- Error connecting to a remote station via DICOM ...
- Error while deinitializing DCM
- Error while reading from database
- Error while connecting to database
- Error while disconnecting from database
- Error during translation
- Invalid DICOM Dictionary
- Cannot transfer Polar Map Imagesets via DICOM for this release
- Cannot transfer SINOGRAM imagesets via DICOM for this release
- Data Already exists in the database. Database Write did not take place
- "Remote station %s is down"
- "Sinogram Imagesets are not currently supported via DICOM transfer"
- "Dicom Transfer/Export failed: Image does not contain the coordinates of the image plane – Dicom tag (0020,0032)" and one warning
- Warning! Dataset does not match SOP Class or Coercion of Data Elements.

Note - The symbol "%s" denotes the station name of the remote DICOM AE. In some cases this symbol could also be replaced by a combination of the patient name, date and station name.

Proposed Presentation Context Table

The following table shows the proposed presentation contexts for the PET DICOM AE, after the real-world activity "Send"

Presentation Context Table – Proposed					
Abstract Syntax		Transfer Syntax		Role	Extended Negotiation
Name	UID	Name List	UID List		
PET Image Storage	1.2.840.10008.5.1.4.1.1.1.28	Implicit VR Little Endian Explicit VR Little Endian Explicit VR Big Endian	1.2.840.10008.1.2 1.2.840.10008.1.2.1 1.2.840.10008.1.2.2	SCU	None
PET Curve Storage	1.2.840.10008.5.1.4.1.1.1.29	Implicit VR Little Endian Explicit VR Little Endian Explicit VR Big Endian	1.2.840.10008.1.2 1.2.840.10008.1.2.1 1.2.840.10008.1.2.2	SCU	None
Standalone Curve Storage	1.2.840.10008.5.1.4.1.1.9	Implicit VR Little Endian Explicit VR Little Endian Explicit VR Big Endian	1.2.840.10008.1.2 1.2.840.10008.1.2.1 1.2.840.10008.1.2.2	SCU	None
Secondary Capture Image Storage	1.2.840.10008.5.1.4.1.1.7	Implicit VR Little Endian Explicit VR Little Endian Explicit VR Big Endian	1.2.840.10008.1.2 1.2.840.10008.1.2.1 1.2.840.10008.1.2.2	SCU	None
PET Raw data SOP class	1.2.840.113619.4.30	Explicit VR Big Endian	1.2.840.10008.1.2.2	SCU	None

SOP Specific DICOM Conformance Statement for all Storage SOP Classes

This implementation can perform multiple C-STORE operations over a single association. Upon receiving a C-STORE confirmation containing a Successful status, this implementation will perform the next C-STORE operation. The association will be maintained if possible.

Upon receiving a C-STORE confirmation containing a Refused status, this implementation will terminate the association.

Upon receiving a C-STORE confirmation containing a status other than Successful or Refused, this implementation will consider the current request to be a failure but will continue to attempt to send any remaining images in the request on a different association.

Each C-STORE operation supports a configurable “Association Timer.” This timer starts when the association request is sent or received and stops when the association is established. The default time-out value is 100 seconds.

Each C-STORE operation supports a configurable “Session Timer.” This timer starts when an association is established and stops when the association is ended. The default time-out value is 11400 seconds.

Note - A Session Timer of this duration is required to provide a mechanism for the transfer of a complete database between 2 Discovery ST stations. The session timer starts with the transfer of the first image and terminates after the time-out value is reached.

If any of the above timers expires, the association is closed and the operation in progress is considered to be failed.

Following are the status codes that are more specifically processed when receiving messages from a **Storage** SCP equipment :

Service Status	Status Codes	Further Meaning	Application Behavior When receiving Status Codes	Related Fields Processed if received
Refused	A700	Out of resources	The message “NetDicom: Possible Memory Allocation Failure in Remote. Status <a700>” is posted onto the Error Log Utility on the <i>GE Discovery ST</i> .	(0000,0902)
	A710	Image not written into remote SCP’s database.	The message “NetDicom: Remote system unable to write data into temporary file. Status <a710>” is posted onto the Error Log Utility on the <i>GE Discovery ST</i> .	(0000,0902)
	A711	Internal Error in the remote SCP	The message “NetDicom: Remote system unable to post buffer to receive events. Status <a711>” is posted onto the Error Log Utility on the <i>GE Discovery ST</i> .	(0000,0902)
	A712	Remote SCP could not determine size of total data buffer received from the SCU.	The message “NetDicom: Remote system unable to access-determine filesize of incoming data. Status <a712>” is posted onto the Error Log Utility on the <i>GE Discovery ST</i> .	(0000,0902)
	A713	Remote SCP could not determine header data offset for Data IOD transmission	The message “NetDicom: Remote system unable to determine data offset in temporary file. Status <a713>” is posted onto the Error Log Utility on the <i>GE</i>	(0000,0902)

Service Status	Status Codes	Further Meaning	Application Behavior When receiving Status Codes	Related Fields Processed if received
			<i>Discovery ST.</i>	
	A714	Remote SCP received invalid DICOM P-DATA packet from the SCU.	The message "NetDicom: Remote System received invalid data packet. Status <a714>" is posted onto the Error Log Utility on the <i>GE Discovery ST.</i>	(0000,0902)
	A715	Remote SCP could not open temporary file in which it stored data received from the SCU.	The message "NetDicom: Remote System could not re-open temporary file for processing. Status <a715>" is posted onto the Error Log Utility on the <i>GE Discovery ST.</i>	(0000,0902)
	A716	Remote SCP could not read data received from the SCU.	The message "NetDicom: Remote System could not read IOD. Status <a715>" is posted onto the Error Log Utility on the <i>GE Discovery ST.</i>	(0000,0902)
Error	C000	Cannot Understand	The message "NetDicom: Remote system Error - Cannot Understand Error. Status <c000>" is posted onto the Error Log Utility on the <i>GE Discovery ST.</i>	(0000,0901) (0000,0902)
	C001	Remote System failed to Parse DICOM Stream.	The message "NetDicom: Remote system could not parse DICOM stream. Translation Failed. Status <c001>" is posted onto the Error Log Utility on the <i>GE Discovery ST.</i>	(0000,0901) (0000,0902)
	C002	Database Write Failed.	The message "NetDicom: Remote system error - Database write failed. Status <c002>" is posted onto the Error Log Utility on the <i>GE Discovery ST.</i>	(0000,0901) (0000,0902)
	C003	Image already exists on the remote SCP.	The message "NetDicom: Remote system error - Duplicate Transmission! Image already exists. Status <c003>" is posted onto the Error Log Utility on the <i>GE Discovery ST.</i>	(0000,0901) (0000,0902)
	A9xx	Data Set does not match SOP Class	The message "NetDicom: Remote system error - Data did not match SOP Class" is posted onto the Error Log Utility on the <i>GE Discovery ST.</i>	(0000,0901) (0000,0902)
Warning	B000	Coercion of Data Elements	The message "NetDicom: Remote system warning -Coercion of Data Elements. Status <b000>" is posted onto the Error Log Utility on the <i>GE Discovery ST.</i>	(0000,0901) (0000,0902)
	B007	Data Set does not match SOP Class	The message "NetDicom: Remote system warning - IOD does not match SOP Class. Status <b007>" is posted onto the Error Log Utility on the <i>GE Discovery ST.</i>	(0000,0901) (0000,0902)
	B006	Elements Discarded	The message "NetDicom: Remote system warning. Data elements discarded. Status <b006>" is posted onto the Error Log Utility on the <i>GE Discovery ST.</i>	(0000,0901) (0000,0902)

Service Status	Status Codes	Further Meaning	Application Behavior When receiving Status Codes	Related Fields Processed if received
Success	0000		The message "Transfer DB completed successfully" is posted onto the Transfer Log Window.;	None

Note -The error codes A700-A716 and C001-C003 are Discovery ST PET AE Private Status Codes. Discovery ST PET AE will return one of the above mentioned status codes (Refused and Error) in case of Image Send Failure . DICOM PS3.4 provides the flexibility of returning private status codes. GE Discovery ST uses them to provide more information to the user in case of an Image Send failure.

Real-World Activity: Verify - PET Application Entity

Associated Real-World Activity

Service personnel invoke the utility "DICOMping" from the UNIX command line. The PET DICOM Server AE will initiate an association with the remote DICOM AE in order to verify communication at the application level. The success or failure of the verification process is displayed to the user.

Proposed Presentation Context Table

Presentation Context Table - Proposed					
Abstract Syntax		Transfer Syntax		Role	Extended Negotiation
Name	UID	Name List	UID List		
Verification SOP Class	1.2.840.10008.1.1	Implicit VR Little Endian	1.2.840.10008.1.2	SCP	None

SOP Specific DICOM Conformance Statement for Verification SOP Class

The PET DICOM Server AE provides standard conformance to the DICOM Verification Service Class.

Real-World Activity: Query - PET Application Entity

Associated Real-World Activity

The Discovery ST implements the query operation in two levels. The first level of query provides query results pertaining to the Patient & Study Tables only. The second level of query provides results regarding the Series table for a given Patient.

The operator must select a DICOM AE as the Source Station on the Discovery ST Network Operations UI in order to initiate the DICOM Query operation. The PET DICOM Server AE will the initiate an association with the remote AE in order to query the remote AE. The Discovery ST initiates Queries at the Study Level, and allows the user to specify either a Universal Match (wild card query) or a Selective Query based on Patient Name, Patient ID, and/or Study Date (including ranges) for the initial Query. The results of the query operation are indicated on the Level A box of the Network Operations UI. The status of the operation in case of a failure/warning is available through the Discovery ST Error Log Utility.

The Second Level Query operation is initiated by the selection of one of the query results on the Level A box. With, the selection of one of these results a query operation is automatically initiated with no other user intervention. The PET DICOM Server AE will then initiate an association with the remote AE in order to query the remote AE for the given query result. The status of the operation in case of a failure/warning is available through the Discovery ST Error Log Utility.

The Discovery ST makes use of the Study Root Query Model to initiate a Search/Query operation. Details of this model are provided in Section 5 of this document.

Note that for each query operation, typically one association is established. The exception to this is that, if a query fails, the current association is closed and a new query operation is re-initiated automatically. If this fails as well, the operation terminates with a failure status and the appropriate errors are logged and are accessible through the Discovery ST Error Log Utility.

The UI indicates the status of the on-going Query operation through a textual status on the bottom left hand corner of the Network Operations UI.

Proposed Presentation Context Table

The following table shows the proposed presentation contexts for the PET DICOM Server AE, after the real-world activity “Query”

Presentation Context Table – Proposed					
Abstract Syntax		Transfer Syntax		Role	Extended Negotiation
Name	UID	Name List	UID List		
Study Root Query/Retrieve Information Model - FIND	1.2.840.10008.5.1.4.1.2.2 .1	Implicit VR Little Endian	1.2.840.10008.1.2	SCU	None
		Explicit VR Little Endian	1.2.840.10008.1.2.1		
		Explicit VR Big Endian	1.2.840.10008.1.2.2		
			2		

SOP Specific DICOM Conformance Statement for the Study Root Query/Retrieve Information Model - FIND SOP Class

This implementation can perform multiple C-FIND operations over a single association.

Upon receiving a C-FIND confirmation containing a Success status, this implementation will perform the next C-FIND operation. The association will be maintained if possible.

Upon receiving a C-FIND confirmation containing a Pending status, this implementation will wait for further C-FIND responses from the remote DICOM AE.

Upon receiving a C-FIND confirmation containing a Refused status, this implementation will terminate the association.

Upon receiving a C-FIND confirmation containing a status other than Successful, Pending or Refused, this implementation will consider the current request to be a failure but will continue to attempt to send any remaining images in the request on a different association.

Each C-FIND operation supports a configurable “Association Timer.” This timer starts when the association request is sent or received and stops when the association is established. The default time-out value is 100 seconds.

Each C-FIND operation supports a configurable “Session Timer.” This timer starts when an association is established and stops when the association is ended. The default time-out value is 11400 seconds.

Note - A Session Timer of this duration is required to provide a mechanism for the transfer of a complete database between 2 Discovery ST stations. The timer starts with the transfer of the first image and terminates after the time-out value is reached.

If any of the above timers expires, the association is closed and the operation in progress is considered failed.

Following are the status codes that are more specifically processed when receiving messages from a **Query** SCP equipment :

Service Status	Status Codes	Further Meaning	Application Behavior When receiving Status Codes	Related Fields Processed
-----------------------	---------------------	------------------------	---	---------------------------------

				if received
Refused	A700	Out of resources	The message "NetDicom: Possible Memory Allocation Failure in Remote. Status <a700>" is posted onto the Error Log Utility on the <i>GE Discovery ST</i> .	(0000,0902)
Failed	A900	Identifier does not match SOP Class	The message "NetDicom: Remote system error - Data did not match SOP Class" is posted onto the Error Log Utility on the <i>GE Discovery ST</i> .	(0000,0901) (0000,0902)
	Cxxx	Unable to process	The message "NetDicom: Remote system Error - Cannot Understand Error. Status <cxxx>" is posted onto the Error Log Utility on the <i>GE Discovery ST</i> .	(0000,0901) (0000,0902)
Cancel	FE00	Matching terminated due to cancel	The message "Canceling DICOM Query" is posted on the bottom left hand corner of the Network Operations UI. This message persists as long as the Query is not canceled. Once the query operation is canceled, this message disappears.	None
Success	0000	Matching is complete - No final identifier is supplied	The message "Querying Remote station via DICOM" is posted on the bottom left hand corner of the Network Operations UI when the query operation is in progress. This message disappears once the query operation is complete.	None
Pending	FF00	Matches are continuing - Current Match is supplied and any Optional Keys were supported in the same manner as Required Keys.	The message "Querying Remote station via DICOM" is posted on the bottom left hand corner of the Network Operations UI. This message persists as long as the query operation is in progress.	Identifier
	FF01	Matches are continuing - Warning that one or more Optional Keys were not supported for existence and/or matching for this Identifier	- No user visible output -	Identifier

Real-World Activity: Retrieve - PET Application Entity

Associated Real-World Activity

The **Discovery ST** operator can fetch data from a remote DICOM AE in the following manner. The operator initiates a DICOM Query as described in previous section. The second step involves invocation of the Fetch/Transfer operation by the selection of one or more search results (Study/Series/Image results) on the Level A or Level B boxes on the Network Operations UI, and then pushing the "Transfer" button to initiate the operation. The PET DICOM Server AE will then initiate an association with the remote AE in order to fetch DICOM imagesets from the remote AE for the given Study/Series/Image selection. The status of the operation is logged onto the Transfer Log.

The Discovery ST makes use of the Study Root Query Model to initiate a Retrieve operation. Details of this model are provided in Section 5 of this document.

Note that for each retrieve operation, typically one association is established. The exception to this is that, if a retrieve fails, the current association is closed and another is opened for retrieving the remaining data (image(s), curves data).

The UI indicates the status of the on-going Retrieve/Fetch/Transfer operation through the Transfer in Progress Window and a textual status on the bottom left hand corner of the Network Operations UI, which indicates the status of the Retrieve operation. Typical error messages that may appear on the Transfer Log after the completion of a Retrieve operation can be one of the following -

- "%s - Transfer completed"
- "%s - Error during transfer"
- "%s - Transfer completed with errors"
- "DICOM Transfer operation has been canceled"
- Error while initializing DCM...
- Error connecting to a remote station via DICOM ...
- Error while deinitializing DCM
- Error during translation
- Invalid DICOM Dictionary
- "%s - Error while fetching from remote station"
- "%s - Fetched from remote station"
- "DICOM Fetch completed on remote station"
- "DICOM Fetch completed with errors. %d items not fetched"
- "DICOM Fetch completed because of user cancel. %d items not fetched"
- "Selected exams have no imagesets to transfer"
- "Remote station %s is down"
- "Sinogram Imagesets are not currently supported via DICOM transfer"
- "PolarMap/BullsEye Imagesets are not currently supported via DICOM transfer"
- "Already exists in the local database. Not fetching from remote"
- "Dicom Transfer/Export failed: Image does not contain the coordinates of the image plane – Dicom tag (0020,0032)"

Note - The symbol "%s" denotes the station name of the remote DICOM AE. In some cases this symbol could also be replaced by a combination of the patient name, date and station name. The symbol "%d" denotes an integer value.

Proposed Presentation Context Table

The following table shows the proposed presentation contexts for the PET DICOM Server AE, after the real-world activity "Retrieve"

Presentation Context Table - Proposed					
Abstract Syntax		Transfer Syntax		Role	Extended Negotiation
Name	UID	Name List	UID List		
Study Root Query/Retrieve Information Model - MOVE	1.2.840.10008.5.1.4.1.2.2.2	Implicit VR Little Endian	1.2.840.10008.1.2	SCU	None
		Explicit VR Little Endian	1.2.840.10008.1.2.1		
		Explicit VR Big Endian	1.2.840.10008.1.2.2		
			2		

This implementation can perform multiple C-MOVE operations over a single association. Upon receiving a C-MOVE confirmation containing a Successful status, this implementation will perform the next C-MOVE operation. The association will be maintained if possible.

Upon receiving a C-MOVE confirmation containing a Pending status, this implementation will wait for further C-MOVE responses from the remote DICOM AE.

Upon receiving a C-MOVE confirmation containing a Refused status, this implementation will terminate the association.

Upon receiving a C-MOVE confirmation containing a status other than Successful, Pending or Refused, this implementation will consider the current request to be a failure but will continue to attempt to send any remaining images in the request on a different association.

Each C-MOVE operation supports a configurable “Association Timer.” This timer starts when the association request is sent or received and stops when the association is established. The default time-out value is 100 seconds.

Each C-MOVE operation supports a configurable “Session Timer.” This timer starts when an association is established and stops when the association is ended. The default time-out value is 11400 seconds.

Note - A Session Timer of this duration is required to provide a mechanism for the transfer of a complete database between 2 Discovery ST stations. The session timer starts with the transfer of the first image and terminates after the time-out value is reached.

If any of the above timers expires, the association is closed and the operation in progress is considered failed.

Following are the status codes that are more specifically processed when receiving messages from a **Retrieve** SCP equipment:

Service Status	Status Codes	Further Meaning	Application Behavior When receiving Status Codes	Related Fields Processed if received
Refused	A701	Out of resources - Unable to calculate number of matches	The message “Error! Remote station could not send data” is posted on the Transfer Log on the Network Operations UI.	(0000,0902)
	A702	Out of resources - Unable to perform sub-operations	The message “Error! Remote station could not send data” is posted on the Transfer Log on the Network Operations UI.	(0000,1021) (0000,1022) (0000,1023)
	A801	Move Destination Unknown	The message “Error! Remote station is not configured to send data to local station” is posted on the Transfer Log on the Network Operations UI.	(0000,0902)
Failed	A900	Identifier does not match SOP Class	The message “Error! Remote station could not match identifier with SOP Class” is posted on the Transfer Log on the Network Operations UI.	(0000,0901) (0000,0902)
	Cxxx	Unable to process	The message “Error! Remote station failed in processing data” is posted on the Transfer Log on the Network Operations UI.	(0000,0901) (0000,0902)
Cancel	FE00	Sub-operations terminated	The message “DICOM Fetch completed	(0000,1020)

Service Status	Status Codes	Further Meaning	Application Behavior When receiving Status Codes	Related Fields Processed if received
		due to a Cancel indication	because of user cancel. N items not fetched." is posted on the Transfer Log on the Network Operations UI.	(0000,1021) (0000,1022) (0000,1023)
Warning	B000	Sub-operations Complete - One or more Failures.	The message "Warning status received from remote DICOM station during fetch" is posted on the Transfer Log on the Network Operations UI.	(0000,1021) (0000,1022) (0000,1023)
Success	0000	Sub-operations Complete - No Failure.	The message "DICOM Fetch completed on remote station" is posted on the Transfer Log on the Network Operations UI.	(0000,1021) (0000,1022) (0000,1023)
Pending	FF00	Sub-operations are continuing -	The message "Transfer DB started" is posted on the Transfer Log on the Network Operations UI.	(0000,1020) (0000,1021) (0000,1022) (0000,1023)

2.2.5.1.1.3 Association Acceptance Policy - PET Application Entity

The PET DICOM Server AE places limitation on who may connect to it depending on its configuration. The operator must configure the AE Title, Port Number, and IP Address of the remote workstation for Query, Verify , and PET/Curve transfers.

The PET DICOM Server AE responds to image store operations from remote AE's. Any Remote AE can request and receive a list of images located in the local Discovery ST database. Any Remote AE can send images (PET Image/Stand alone Curve/PET Curve/GE Discovery ST PET Data) to the Discovery ST to be stored in the local database.

Any remote AE can open an association to the PET DICOM Server AE for the purpose of application level communication verification.

The PET DICOM Server AE responds to query requests from remote AE's and responds with matching responses if remote AE is configured in Discovery ST. Remote AE can also request the PET DICOM Server AE to retrieve image data from theDiscovery ST, and to store this data in the database of the remote AE.

Real-World Activity - Image Store SCP - PET Application Entity

Associated Real-World Activity

The PET DICOM Server AE is always listening for associations. No operator action is required to respond to a Store request.

The real-world activity associated with the Store request is to store the image data in the local database and send a C-STORE -RSP message with the status of "success" for each image that can be stored in the local database. A C-STORE-RSP message with the status "failed" is sent for each image that cannot be stored in the local database.

The following are the Presentation Context supported by PET DICOM Server AE Server:

Presentation Context Table – Accepted					
Abstract Syntax		Transfer Syntax		Role	Extended Negotiation
Name	UID	Name List	UID List		
PET Image Storage	1.2.840.10008.5.1.4.1.1.1 28	Implicit VR Little Endian Explicit VR Little Endian Explicit VR Big Endian	1.2.840.10008.1.2 1.2.840.10008.1.2.1 1.2.840.10008.1.2.2	SCP	None
PET Curve Storage	1.2.840.10008.5.1.4.1.1.1 29	Implicit VR Little Endian Explicit VR Little Endian Explicit VR Big Endian	1.2.840.10008.1.2 1.2.840.10008.1.2.1 1.2.840.10008.1.2.2	SCP	None
Standalone Curve Storage	1.2.840.10008.5.1.4.1.1.9	Implicit VR Little Endian Explicit VR Little Endian Explicit VR Big Endian	1.2.840.10008.1.2 1.2.840.10008.1.2.1 1.2.840.10008.1.2.2	SCP	None
Secondary Capture Image Storage	1.2.840.10008.5.1.4.1.1.7	Implicit VR Little Endian Explicit VR Little Endian Explicit VR Big Endian	1.2.840.10008.1.2 1.2.840.10008.1.2.1 1.2.840.10008.1.2.2	SCP	None
CT Image Storage	1.2.840.10008.5.1.4.1.1.2	Implicit VR Little Endian	1.2.840.10008.1.2	SCP	None
MR Image Storage	1.2.840.10008.5.1.4.1.1.4	Implicit VR Little Endian	1.2.840.10008.1.2	SCP	None
PET Raw data SOP class	1.2.840.113619.4.30	Explicit VR Big Endian	1.2.840.10008.1.2.2	SCP	None

SOP Specific DICOM Conformance Statement for all Storage SOP Classes

The Discovery ST provides Level 1 Storage support as defined in the DICOM Standards. (Refer DICOM PS3.4 for further details on level of conformance). This implies that it may discard any Type 3 attributes, including Private Data Elements. The Discovery ST PET AE preserves Type 3 attributes that have a logical, analogous field in the PET database. Following are the status codes the application may send back to the SCU Equipment after performing the requested **Storage**:

Service Status	Status Codes	Further Meaning	Status Code sending explanation	Related Fields sent back to the SCU
Refused	A700	Out of resources	Insufficient memory to carry out further operations.	(0000,0902)
	A710	Image not written into SCP's database.	Unable to write incoming image data into temporary file. Mainly due to non-availability of system resources.	(0000,0902)
	A711	Internal Error in the SCP	Unable to post a buffer to receive events from the SCU.	(0000,0902)

Service Status	Status Codes	Further Meaning	Status Code sending explanation	Related Fields sent back to the SCU
	A712	SCP could not determine size of total data buffer received from the SCU.	Unable to access-determine filesize of incoming data.	(0000,0902)
	A713	SCP could not determine header data offset for Data IOD transmission	Unable to determine data offset in temporary file.	(0000,0902)
	A714	SCP received invalid DICOM P-DATA packet from the SCU.	Received invalid data packet from SCU.	(0000,0902)
	A715	SCP could not open temporary file in which it stored data received from the SCU.	Could not re-open temporary file for processing..	(0000,0902)
	A716	SCP could not read data received from the SCU.	Cold not read IOD received from the SCU.	(0000,0902)
Error	C000	Cannot Understand	Cannot Understand Error.	(0000,0901) (0000,0902)
	C001	System failed to Parse DICOM Stream.	Could not parse DICOM stream. Translation Failed.	(0000,0901) (0000,0902)
	C002	Database Write Failed.	Database write failed.	(0000,0901) (0000,0902)
	C003	Image already exists on the SCP.	Duplicate Transmission! Image already exists in the local database.	(0000,0901) (0000,0902)
	A900	Data Set does not match SOP Class	Data did not match SOP Class	(0000,0901) (0000,0902)
Warning	B000	Coercion of Data Elements	Coercion of Data Elements.	(0000,0901) (0000,0902)
	B007	Data Set does not match SOP Class	IOD does not match SOP Class.	(0000,0901) (0000,0902)
	B006	Elements Discarded	Data elements discarded.	(0000,0901) (0000,0902)
Success	0000			None

Note -The error codes A700-A716 and C001-C003 are Discovery ST PET AE Private Status Codes. Discovery STstations will return one of the above mentioned status codes (Refused and Error) in case of Image Send Failure. DICOM PS3.4 provides the flexibility of returning private status codes. Discovery ST uses them to provide more information to the user in case of an Image Send failure.

Presentation Context Acceptance Criterion

The Presentation Context accepted by the PET DICOM Server has to be one supported by the PET DICOM Server and to which the remote Image Store SCU has accorded the highest priority.

Transfer Syntax Selection Policies

No specific Transfer Syntax selection policy is applied for a given presentation context. The first transfer syntax to be proposed amongst a set of transfer syntax for a given SOP class, by the SCU, will be considered for negotiation by the PET DICOM Server. However, if the PET DICOM Server fails to support this transfer syntax, it shall then negotiate with the next transfer syntax proposed by the remote SCU, for the specific SOP class in question and so on. If the PET DICOM Server does not support any of the transfer syntax proposed by the SCU, the association negotiation shall fail.

Real-World Activity: Query SCP - PET Application Entity

Associated Real-World Activity

The PET DICOM Server AE is always listening for associations. No operator action is required to respond to Query request.

The real-world activity associated with the Query request is to search the local database for all entries that match the request and send a C-FIND-RSP message with the status of “pending” for each matching entry. The exception to this is the last message which is sent with a status of “success.”

Accepted Presentation Context Table

Presentation Context Table - Accepted					
Abstract Syntax		Transfer Syntax		Role	Extended Negotiation
Name	UID	Name List	UID List		
Patient Root Query/Retrieve Information Model - FIND	1.2.840.10008.5.1.4.1.2.1.1	Implicit VR Little Endian Explicit VR Little Endian Explicit VR Big Endian	1.2.840.10008.1.2 1.2.840.10008.1.2.1 1.2.840.10008.1.2.2	SCP	None
Study Root Query/Retrieve Information Model - FIND	1.2.840.10008.5.1.4.1.2.2.1	Implicit VR Little Endian Explicit VR Little Endian Explicit VR Big Endian	1.2.840.10008.1.2 1.2.840.10008.1.2.1 1.2.840.10008.1.2.2	SCP	None

Note that this implementation does not support extended negotiation for the C-FIND Service, including that for relational-queries.

SOP Specific DICOM Conformance Statement for the Patient Root Query/Retrieve Information Model – FIND and Study Root Query/Retrieve Information Model - FIND

Following are the status codes the Application may send back to the SCU Equipment after performing the requested **Query**:

Service Status	Status Codes	Further Meaning	Status Code sending explanation	Related Fields Processed if received
Refused	A700	Out of resources	Returned if the DICOM Server runs out of resources (e.g. memory); error logged.	(0000,0902)
Failed	A900	Identifier does not match SOP Class	Returned if the incoming data did not match SOP Class	(0000,0901) (0000,0902)
	C000	Unable to process	Returned by the DICOM Server if for any other reason, not specified elsewhere in this table, the Find operation failed; error logged.	(0000,0901) (0000,0902)
Cancel	FE00	Matching terminated due to cancel	Returned if the DICOM Server receives a C-CANCEL-FIND-RQ message; error logged.	None
Success	0000	Matching is complete - No final identifier is supplied	Returned when the DICOM Server completes the find operation.	None
Pending	FF00	Matches are continuing - Current Match is supplied and any Optional Keys were supported in the same manner as Required	Returned by the DICOM Server for every match found.	Identifier

Service Status	Status Codes	Further Meaning	Status Code sending explanation	Related Fields Processed if received
		Keys.		
	FF01	Matches are continuing - Warning that one or more Optional Keys were not supported for existence and/or matching for this Identifier	Returned by the DICOM Server if one or more Optional Keys were not supported for existence and/or matching.	Identifier

Presentation Context Acceptance Criterion

The Presentation Context accepted by the PET DICOM Server has to be one supported by the PET DICOM Server and to which the remote Query SCU has accorded the highest priority.

Transfer Syntax Selection Policies

No specific Transfer Syntax selection policy is applied for a given presentation context. The first transfer syntax to be proposed amongst a set of transfer syntax for a given SOP class, by the SCU, will be considered for negotiation by the PET DICOM Server. However, if the PET DICOM Server fails to support this transfer syntax, it shall then negotiate with the next transfer syntax proposed by the remote SCU, for the specific SOP class in question and so on. If the PET DICOM Server does not support any of the transfer syntax proposed by the SCU, the association negotiation shall fail.

Real-World Activity: Image Retrieve SCP - PET Application Entity

Associated Real-World Activity

The PET DICOM Server AE is always listening for associations. No operator action is required to respond to an Image Retrieve request.

The real-world activity associated with the Image Retrieve request is to send all images, curves data corresponding to the C-MOVE request to the specified destination AE through a separate association.

Accepted Presentation Context Table

Presentation Context Table - Accepted					
Abstract Syntax		Transfer Syntax		Role	Extended Negotiation
Name	UID	Name List	UID List		
Patient Root Query/Retrieve Information Model - MOVE	1.2.840.10008.5.1.4.1.2.1.2	Implicit VR Little Endian Explicit VR Little Endian Explicit VR Big Endian	1.2.840.10008.1.2 1.2.840.10008.1.2.1 1.2.840.10008.1.2.2	SCP	None
Study Root Query/Retrieve Information Model - MOVE	1.2.840.10008.5.1.4.1.2.2.2	Implicit VR Little Endian Explicit VR Little Endian Explicit VR Big Endian	1.2.840.10008.1.2 1.2.840.10008.1.2.1 1.2.840.10008.1.2.2	SCP	None

Note that this implementation does not support extended negotiation for the C-MOVE Service, including that for relational-retrieve.

SOP Specific DICOM Conformance Statement for the Patient Root Query/Retrieve Information Model – MOVE and Study Root Query/Retrieve Information Model - MOVE SOP Classes

Following are the status codes the Application may send back to the SCU Equipment after performing the requested **Retrieve**:

Service Status	Status Codes	Further Meaning	Status Code sending explanation	Related Fields Processed if received
Refused	A701	Out of resources - Unable to calculate number of matches	Returned if the DICOM Server can't find requested SOP instance(s); error logged.	(0000,0902)
	A702	Out of resources - Unable to perform sub-operations	Returned if the DICOM Server runs out of resources (e.g. memory); error logged.	(0000,1021) (0000,1022) (0000,1023)
	A801	Move Destination Unknown	Returned if the DICOM Server has no information on destination AE; error logged.	(0000,0902)
Failed	A900	Identifier does not match SOP Class	Returned if the DICOM Server receives other than the Patient Root Query/Retrieve Information Model or Study Root Query/Retrieve Information Model SOP class.	(0000,0901) (0000,0902)
	C000	Unable to process	Returned if the DICOM Server cannot successfully interpret the C-MOVE-RQ message.	(0000,0901) (0000,0902)
Cancel	FE00	Sub-operations terminated due to a Cancel indication	Returned if the DICOM Server receives a C-CANCEL-MOVE-RQ message.	(0000,1020) (0000,1021) (0000,1022) (0000,1023)
Warning	B000	Sub-operations Complete - One or more Failures.	Returned upon completion if one or more of the specified images failed to transfer to the destination AE.	(0000,1021) (0000,1022) (0000,1023)
Success	0000	Sub-operations Complete - No Failure.	Returned after the transfer of the last image.	(0000,1021) (0000,1022) (0000,1023)
Pending	FF00	Sub-operations are continuing -	Returned after the transfer of each imageset (series) except for the last.	(0000,1020) (0000,1021) (0000,1022) (0000,1023)

Presentation Context Acceptance Criterion

The Presentation Context accepted by the PET DICOM Server has to be one supported by the PET DICOM Server and to which the remote Retrieve SCU has accorded the highest priority.

Transfer Syntax Selection Policies

No specific Transfer Syntax selection policy is applied for a given presentation context. The first transfer syntax to be proposed amongst a set of transfer syntax for a given SOP class, by the SCU, will be considered for negotiation by the PET DICOM Server. However, if the PET DICOM Server fails to support this transfer syntax, it shall then negotiate with the next transfer syntax proposed by the remote SCU, for the specific SOP class in question and so on. If the PET DICOM Server does not support any of the transfer syntax proposed by the SCU, the association negotiation shall fail.

Real-World Activity: Verify SCP - PET Application Entity

Associated Real-World Activity

The PET DICOM Server AE is always listening for associations. No operator action is required to respond to a Verification request.

The real-world activity associated with the Verification request is to send a C-ECHO-RSP message with a status of “success” to the requesting AE.

Accepted Presentation Context Table

Presentation Context Table - Accepted					
Abstract Syntax		Transfer Syntax		Role	Extended Negotiation
Name	UID	Name List	UID List		
Verification SOP Class	1.2.840.10008.1.1	Implicit VR Little Endian	1.2.840.10008.1.2	SCP	None

SOP Specific DICOM Conformance Statement for Verification SOP Class

The PET DICOM Server AE provides standard conformance to the DICOM Verification service class.

Presentation Context Acceptance Criterion

The Presentation Context accepted by the PET DICOM Server has to be one supported by the PET DICOM Server and to which the remote Verification SCU has accorded the highest priority.

Transfer Syntax Selection Policies

No specific Transfer Syntax selection policy is applied for a given presentation context. The first transfer syntax to be proposed amongst a set of transfer syntax for a given SOP class, by the SCU, will be considered for negotiation by the PET DICOM Server. However, if the PET DICOM Server fails to support this transfer syntax, it shall then negotiate with the next transfer syntax proposed by the remote SCU, for the specific SOP class in question and so on. If the PET DICOM Server does not support any of the transfer syntax proposed by the SCU, the association negotiation shall fail.

2.2.5.2 COMMUNICATION PROFILES - PET Application Entity

2.2.5.2.1 Supported Communication Stacks (PS 3.8, PS 3.9)

DICOM Upper Layer (PS 3.8) is supported using TCP/IP.

2.2.5.2.2 OSI Stack

OSI stack not supported

2.2.5.2.3 TCP/IP Stack

The TCP/IP stack is inherited from a UNIX Operating System.

2.2.5.2.3.1 API

Not applicable to this product.

2.2.5.2.3.2 Physical Media Support

DICOM is indifferent to the Physical medium over which TCP/IP executes (e.g. Ethernet V2.0, IEEE 802.3, ATM, FDDI)

Note: For more information about the Physical Media available on the GE Discovery ST PET AE please refer to the Product Data Sheet.

2.2.5.2.4 Point-to-Point Stack

A 50-pin ACR-NEMA connection is not applicable to this product.

2.2.5.3 EXTENSIONS / SPECIALIZATIONS / PRIVATIZATIONS - PET Application Entity**2.2.5.3.1 Standard Extended /Specialized/Private SOPs****2.2.5.3.2 Private Transfer Syntaxes**

The Discovery ST does not implement any private transfer syntaxes.

2.2.5.4 CONFIGURATION - PET Application Entity

The Discovery ST system is configured by GEMS Field Service Engineers. The DICOM configuration items below are configurable or re-configurable by a Field Service Engineer but are not accessible through the Discovery ST user interface.

2.2.5.4.1 AE Title/Presentation Address Mapping

The Discovery ST allows for the configuration of the mapping of remote AE titles to IP addresses and ports. The IP address of a remote AE may be in a different sub net (using routing). This configuration is performed by GEMS Field Service Engineers.

2.2.5.4.2 Configurable Parameters

The following fields are configurable for the PET DICOM Server AE (local):

- Local AE Title (Configurable, but by default, set to hostname of the GE Discovery ST PET computer in all capitals (CAPS))
- Local IP Address
- Local IP Netmask

Note that the port on which the Discovery ST receives DICOM incoming TCP/IP connections is **4030** (for Query, Verify, and Send/Receive/Query-Retrieve PET Image/Curve/Secondary Capture data, and Receive/Query-Retrieve CT/MR data).

The following fields are configurable for every remote DICOM AE:

- Remote AE Title
- Remote IP Address
- Listening TCP/IP Port Number

The following fields are configurable:

- Association Establishment Timer
- Store, Find, Move, Timers
- Inactivity Timers
- Maximum Length PDU
- Number of simultaneous associations

Note: All configurations must be performed by a GE Field Engineer.

2.2.5.5 SUPPORT OF EXTENDED CHARACTER SETS - PET Application Entity

In addition to the DICOM default character set, *Discovery ST PET DICOM Server AE* supports the ISO IR 100 Latin alphabet #1 supplementary set for the purpose of interchange

2.2.6 Xeleris Application Entity

2.2.6.1 DICOM AE Specifications

This Application Entity provides Standard Conformance to the following DICOM SOP Classes as an SCU:

SOP Class Name	SOP Class UID
Nuclear Medicine Image Storage	1.2.840.10008.5.1.4.1.1.20
Secondary Capture Image Storage	1.2.840.10008.5.1.4.1.1.7
Xeleris Private SOP Class Storage	1.2.840.113619.4.27
Stand-alone Curve Storage	1.2.840.10008.5.1.4.1.1.9
Study Root Query/Retrieve Information Model – FIND	1.2.840.10008.5.1.4.1.2.2.1
Study Root Query/Retrieve Information Model – MOVE	1.2.840.10008.5.1.4.1.2.2.2
Verification – ECHO	1.2.840.10008.1.1
CT Image Storage	1.2.840.10008.5.1.4.1.1.2
PET Image Storage	1.2.840.10008.5.1.4.1.1.128
MR Image Storage	1.2.840.10008.5.1.4.1.1.4
GE Private PET RAW data storage	1.2.840.113619.4.30

This Application Entity provides Standard Conformance to the following DICOM SOP Classes as an SCP:

SOP Class Name	SOP Class UID
Nuclear Medicine Image Storage	1.2.840.10008.5.1.4.1.1.20
MR Image Storage	1.2.840.10008.5.1.4.1.1.4
Secondary Capture Image Storage	1.2.840.10008.5.1.4.1.1.7
Xeleris Private SOP Class Storage	1.2.840.113619.4.27
Stand-alone Curve Storage	1.2.840.10008.5.1.4.1.1.9
CT Image Storage	1.2.840.10008.5.1.4.1.1.2
Patient Root Query/Retrieve Information Model – FIND	1.2.840.10008.5.1.4.1.2.1.1

Patient Root Query/Retrieve Information Model – MOVE	1.2.840.10008.5.1.4.1.2.1.2
Study Root Query/Retrieve Information Model – FIND	1.2.840.10008.5.1.4.1.2.2.1
Study Root Query/Retrieve Information Model – MOVE	1.2.840.10008.5.1.4.1.2.2.2
Verification – ECHO	1.2.840.10008.1.1
PET Image Storage	1.2.840.10008.5.1.4.1.1.128
GE Private PET RAW data storage	1.2.840.113619.4.30

2.2.6.1.1 Association Establishment Policies - Xeleris Application Entity

2.2.6.1.1.1 General

The DICOM Application Context Name (ACN), which is always proposed, is:

Application Context Name	1.2.840.10008.3.1.1.1
---------------------------------	------------------------------

The Maximum Length PDU negotiation is included in all association establishment requests. The maximum length PDU for an association initiated by the XELERIS DICOM Server is:

Maximum Length PDU	128K Bytes
---------------------------	-------------------

The SOP Class Extended Negotiation is not supported.
 The maximum number of Presentation Context Items that will be proposed is 8. Note that the same Abstract Syntax may be offered multiple times with different Transfer Syntaxes.

The user information Items sent by this product are:

- Maximum PDU Length
- Implementation UID

2.2.6.1.1.2 Number of Associations

The XELERIS DICOM Server AE (SCU) will initiate only one DICOM association at a time to perform an image store to a single remote AE. A maximum of three associations can be open at any point of time in order to perform Send, Query and Retrieve operations. Multiple Send and Retrieve operations can be performed. Simultaneous Query operations cannot be initiated. The total number of associations are restricted to a maximum of three, and can be any permutation/combination of the above.

The XELERIS DICOM Server AE (SCP) can have a maximum of four DICOM associations open simultaneously to service queries, retrieves or verifications.

2.2.6.1.1.3 Asynchronous Nature

Asynchronous mode is not supported. All operations are performed synchronously.

The Implementation UID for this DICOM Implementation is:

Xeleris/eNTEGRA Processing & Review Implementation UID	1.2.840.113619.6.112
---	-----------------------------

2.2.6.1.2 Association Initiation Policies - Xeleris Application Entity

The XELERIS DICOM Server AE initiates a new association

- Due to an image send operation being initiated from the Xeleris/eNTEGRA user interface
 - Due to a Verify operation initiated to determine whether the remote DICOM station is operational.
 - Due to image data being Queried from a Remote AE, the query operation being initiated from Xeleris/eNTEGRA Search/Fetch user interface.
 - Due to image data being Retrieved from a Remote AE. the retrieve operation being initiated from Xeleris/eNTEGRA’s Search/Fetch user interface.

2.2.6.1.2.1 Real-World Activity: Image Send - Xeleris Application Entity

Associated Real-World Activity

The operator must both select image(s) to be transferred from the Patient Selector and select a destination from the Network Card. Once these selections have been made, the operator pushes the “Send” button to initiate an image send operation. The XELERIS DICOM Server will then initiate an association with the remote AE in order to send the selected image(s).

Note that for each send operation, typically one association is established. The exception to this is that, if an image send fails, the current association is closed and another is opened for sending the remaining image(s).

The UI will indicate the status of the dataset being transferred. The status can be one of CONNECTING, ACTIVE, COMPLETED or FAILED. The associated error messages due to a failed status can be one of the following -•

Fatal System Error! Cannot Send

- Out of system memory: Cannot Send!
- Exceeded the Maximum Job Limit
- Error in Database Access
- DICOM Station Configuration Error
- DICOM Configuration Error
- Failed to connect to DICOM Station
- DICOM Protocol Error
- Failed to disconnect from DICOM station
- Remote Database Write Error
- Remote DICOM station failed to respond or Remote station is down
- Unknown Error returned from Remote Station and one warning
- Warning! Dataset does not match SOP Class or Coercion of Data Elements.

Proposed Presentation Context Table

The following table shows the proposed presentation contexts for the XELERIS DICOM Server AE after real-world activity "Image Send" has been initiated.

Presentation Context Table - Proposed

Abstract Syntax		Transfer Syntax		Role	Extended Negotiation
Name	UID	Name List	UID List		
Nuclear Medicine Image Storage	1.2.840.10008.5.1.4.1.1.20	Implicit VR Little Endian	1.2.840.10008.1.2	SCU	None
		Explicit VR Little Endian	1.2.840.10008.1.2.1		
Stand-Alone Curve Storage	1.2.840.10008.5.1.4.1.1.9	Implicit VR Little Endian	1.2.840.10008.1.2	SCU	None
		Explicit VR Little Endian	1.2.840.10008.1.2.1		
Xeleris Private SOP Class Storage	1.2.840.113619.4.27	Implicit VR Little Endian	1.2.840.10008.1.2	SCU	None
		Explicit VR Little Endian	1.2.840.10008.1.2.1		
Secondary Image Capture Storage	1.2.840.10008.5.1.4.1.1.7	Implicit VR Little Endian	1.2.840.10008.1.2	SCU	None
		Explicit VR Little Endian	1.2.840.10008.1.2.1		
CT Image Storage	1.2.840.10008.5.1.4.1.1.2	Implicit VR Little Endian	1.2.840.10008.1.2	SCU	None
		Explicit VR Little Endian	1.2.840.10008.1.2.1		
PET Image Storage	1.2.840.10008.5.1.4.1.1.128	Implicit VR Little Endian	1.2.840.10008.1.2	SCU	None
		Explicit VR Little Endian	1.2.840.10008.1.2.1		
PET private RAW data storage	1.2.840.113619.4.30	Implicit VR Little Endian	1.2.840.10008.1.2	SCU	None
		Explicit VR Little Endian	1.2.840.10008.1.2.1		
		Explicit VR Big Endian	1.2.840.10008.1.2.2		

SOP Specific DICOM Conformance Statement for all Storage SOP Classes

This implementation can perform multiple C-STORE operations over a single association. Upon receiving a C-STORE confirmation containing a Successful status, this implementation will perform the next C-STORE operation. The association will be maintained if possible. Upon receiving a C-STORE confirmation containing a Refused status, this implementation will terminate the association. Upon receiving a C-STORE confirmation containing a status other than Successful or Warning, this implementation will consider the current request to be a failure but will continue to attempt to send any remaining images in the request on a different association.

Following are the status codes that are more specifically processed when receiving messages from **Storage** SCP equipment:

Service Status	Status Codes	Further Meaning	Application Behaviour while receiving Status Codes
Refused	A700	Out of resources.	The message "DICOM Protocol Error" posted on the Log Card
	A710	Out of resources.	The message "Remote Database could not write dataset" posted to the network Log card.
	A720	Out of resources.	The message "Internal Error on the Remote Station" posted to the network Log card.
	A730	Out of resources.	The message "Error! Translation Failed. Cannot send Dataset" posted to the network Log card.
	A740	Out of resources.	The message "Error! Remote Station could not find Pixel Data" posted to the network Log card.
Error	Cxxx	Cannot Understand	The message "Unknown Error returned from Remote Station" posted to the network Log card.
	A9xx	Data Set does not match SOP Class	The message "Warning!! Dataset does not match SOP Class or Coercion of data elements" posted to the network Log card. The report about store failure is also posted to the network Log card

Warning	B000	Coercion of Data Elements	The message “Warning!! Dataset does not match SOP Class or Coercion of data elements” posted to the network Log card.
	B007	Data Set does not match SOP Class	The message “Warning!! Dataset does not match SOP Class or Coercion of data elements” posted to the network Log card.
	B006	Elements Discarded	The message “Warning!! Dataset does not match SOP Class or Coercion of data elements” posted to the network Log card.
Success	0000		The message “Dataset Transfer Completed” posted to the network Log card.

NOTE: The error codes A700-A740 are Xeleris/eNTEGRA Private Status Codes. Xeleris/eNTEGRA stations will return one of the above mentioned status codes (Refused and Error) in case of Image Send Failure. DICOM PS3.4 provides the flexibility of returning private status codes. Xeleris/eNTEGRA uses them to provide more information to the Xeleris/eNTEGRA user in case of an Image Send failure. If Non-Xeleris/eNTEGRA stations SCP return the same status code, Xeleris/eNTEGRA SCU will interpret them as per the table above. The non-Xeleris/eNTEGRA station’s interpretation of the status code will not be considered.

2.2.6.1.2.2 Real-World Activity: Verify - Xeleris Application Entity

Associated Real-World Activity

Service personnel invoke the utility “sendecho” from the UNIX command line. The AE Title of the remote is supplied on the command line along with the IP address and the port number of the remote DICOM station. The XELERIS DICOM server will initiate an association with the remote DICOM AE in order to verify communication at the application level. The success or failure of the verification process is displayed to the user.

Proposed Presentation Context Table

Presentation Context Table - Proposed					
Abstract Context		Transfer Syntax		Role	Extended Negotiation
Name	UID	Name List	UID List		
Verification SOP Class	1.2.840.10008.1.1	Implicit VR Little Endian	1.2.840.10008.1.2	SCU	None

SOP Specific DICOM Conformance Statement for all Verify SOP Classes

The XELERIS DICOM Server AE provides standard conformance to the DICOM Verification Service Class.

Associated Real-World Activity

Xeleris/eNTEGRA implements the query operation in two levels. The first level of query provides query results pertaining to the Patient & Study Tables only. The second level of query provides results regarding the Series and Image tables for a given Patient. The operator must push the “Search/Fetch Template” button on Xeleris/eNTEGRA Search/Fetch UI. This pops-up a Search/Fetch Template with Patient Name, Patient Id, Study From Date, Study To Date and Study Id (Search Parameters).

The operator must indicate the search criteria by entering the search parameters and then push the “Search” button to initiate the Query operation. The XELERIS DICOM Server will then initiate an association with the remote AE in order to query the remote AE for the given Search Parameters. The results of the Search operation are indicated on the Search/Fetch UI of Xeleris/eNTEGRA. The status of the operation is logged onto the Search/Fetch Log Card.

The Second Level Query operation is initiated by the selection of one or more search results on the Search/Fetch UI and then pushing the “Search Again” button to initiate the operation. The XELERIS DICOM Server will then initiate an association with the remote AE in order to query the remote AE for the given Search Parameters. The results of the Search operation are indicated on the Search/Fetch UI of Xeleris/eNTEGRA. The status of the operation is logged onto the Search/Fetch Log Card.

Xeleris/eNTEGRA makes use of the Study Root Query Model to initiate a Search/Query operation. Details of this model are provided in Section 5 of this document.

Note that for each level of a query operation, a single association is established.

Proposed Presentation Context Table

The following table shows the proposed presentation contexts for the XELERIS DICOM Server AE after real-world activity “Image Query” has been initiated:

Presentation Context Table - Proposed					
Abstract Context		Transfer Syntax		Role	Extended Negotiation
Name	UID	Name List	UID List		
Study Root Query/ Retrieve Information Model - FIND	1.2.840.10008.5.1.4.1.2.2.1	Implicit VR Little Endian	1.2.840.10008.1.2	SCU	None
		Explicit VR Little Endian	1.2.840.10008.1.2.1		

SOP Specific DICOM Conformance Statement for all Query SOP Classes

This implementation can perform multiple C-FIND operations over a single association. Upon receiving a C-FIND confirmation containing a Successful status, this implementation will perform the next C-FIND operation. The association will be maintained if possible. Upon receiving a C-FIND confirmation containing a Pending status, this implementation will wait for further C-FIND responses from the remote DICOM AE. Upon receiving a C-FIND confirmation containing a Refused status, this implementation will terminate the association.

Upon receiving a C-FIND confirmation containing a status other than Successful, Pending or Refused, this implementation will consider the current request to be a failure but will continue to attempt to send any remaining images in the request on a different association.

Following are the status codes that are more specifically processed when receiving, messages from Query SCP equipment:

Service Status	Status Codes	Further Meaning	Application Behaviour while receiving Status Codes
Refused	A700	Out of resources.	The message "DICOM Protocol Error" posted on the Log Card
Cancel	FE00	Matching terminated due to Cancel.	The message "Cancelling in progress. Cannot initiate another search until cancel is complete." is posted to the Search/Fetch Log Card. The message "Search Cancelled. Cancel Acknowledgment Received." is posted to the Search/Fetch Log Card.
Success	0000		The message "Dataset Transfer Completed" posted to the network Log card.
Failed	A900	Identifier does not match SOP Class	The message "Failed to Query Remote DICOM Station" is posted to the Search/Fetch Log Card.
	C000	Unable to process	The message "Remote DICOM station failed to Process Query Request" is posted to the Search/Fetch Log Card.
Pending	FF00	Matches are continuing - Current Match is supplied and any Optional Keys were supported in the same manner as Required Keys.	- No Visible User Output
	FF01	Matches are continuing - Warning that one or more Optional Keys were not supported for existence and/or matching for this Identifier.	A warning message is logged in a log file but is not visible to the operator.

2.2.6.1.2.4 Real-World Activity: Retrieve - Xeleris Application Entity

Associated Real-World Activity

The Xeleris/eNTEGRA operator can fetch data from a remote DICOM AE in two ways. The first mechanism requires the operator to push the “Search/Fetch Template” button on Xeleris/eNTEGRA Search/Fetch UI. This pops-up a Search/Fetch Template with Patient Name, Patient Id, Study From Date, Study To Date and Study Id (Search Parameters).

The operator must indicate the Image Retrieve/Fetch criteria by entering the fetch parameters and then push the “Fetch” button to initiate the Retrieve operation. The XELERIS DICOM Server will then initiate an association with the remote AE in order to fetch DICOM imagesets from the remote AE for the given Fetch Parameters. The status of the operation is logged onto the Search/Fetch Log Card.

The second mechanism involves invocation of the Fetch operation by the selection of one or more search results (Patient/Study/Series/Image results) on the Search/Fetch UI and then pushing the “Fetch” button to initiate the operation. This mechanism assumes that the operator has preceded the Fetch with a Query operation. The XELERIS DICOM Server will then initiate an association with the remote AE in order to fetch DICOM imagesets from the remote AE for the given Patient/Study/Series/Image selection. The status of the operation is logged onto the Search/Fetch Log Card.

Xeleris/eNTEGRA makes use of the Study Root Query Model to initiate a Fetch/Retrieve operation. Details of this model are provided in Section 5 of this document.

Note that for each level of a retrieve operation, a single association is established.

The UI will indicate the status of the on-going Retrieve operation through a dialogue box which indicates the status of the Retrieve operation. Typical error messages that may appear on the Search/Fetch Log Card after the completion of a Retrieve operation can be one of the following:

- Fatal System Error! Cannot Send
- Exceeded the Maximum Job Limit
- DICOM Station Configuration Error
- DICOM Configuration Error
- Failed to connect to DICOM Station
- DICOM Protocol Error
- Failed to disconnect from DICOM station
- Unknown Error returned from Remote Station
- DICOM Formatting Error
- DICOM Retrieve Failed
- DICOM Retrieve Initialization Failed
- Remote DICOM Station unable to send datasets
- Remote DICOM station is not aware of destination station to send datasets
- Remote DICOM station - Database Retrieve Request Failed
- Remote DICOM station - Unable to Process Retrieve Requests
- Remote DICOM station failed to respond or Remote station is down

Proposed Presentation Context Table

The following table shows the proposed presentation contexts for the XELERIS DICOM Server AE after real-world activity “Image Retrieve” has been initiated:

Presentation Context Table - Proposed

Abstract Context		Transfer Syntax		Role	Extended Negotiation
Name	UID	Name List	UID List		
Study Root Query/ Retrieve Information Model - MOVE	1.2.840.10008.5.1.4.1.2.2.2	Implicit VR Little Endian Explicit VR Little Endian	1.2.840.10008 .1.2 1.2.840.10008 .1.2.1	SCU	None

SOP Specific DICOM Conformance Statement for all Query SOP Classes

This implementation can perform multiple C-MOVE operations over a single association. Upon receiving a C-MOVE confirmation containing a Successful status, this implementation will perform the next C-MOVE operation. The association will be maintained if possible. Upon receiving a C-MOVE confirmation containing a Pending status, this implementation will wait for further C-MOVE responses from the remote DICOM AE. Upon receiving a C-MOVE confirmation containing a Refused status, this implementation will terminate the association. Upon receiving a C-MOVE confirmation containing a status other than Successful, Pending or Warning, this implementation will consider the current request to be a failure but will continue to attempt to send any remaining images in the request on a different association. Following are the status codes that are more specifically processed when receiving messages from **Retrieve** SCP equipment:

Service Status	Status Codes	Further Meaning	Application Behaviour while receiving Status Codes
Refused	A700	Out of resources – Unable to calculate number of matches.	The message “Remote DICOM Station unable to send datasets” posted on the Log Card.
	A702	Out of resources – Unable to calculate number of matches.	The message “Remote DICOM Station unable to send datasets” posted on the Log Card.
	A801	Out of resources – Unable to calculate number of matches.	The message “Remote DICOM Station unable to send datasets” posted on the Log Card.

Cancel	FE00	Matching terminated due to Cancel.	The message "Cancelling in progress. Cannot initiate another search until cancel is complete." is posted to the Search/Fetch Log Card. The message "Search Cancelled. Cancel Acknowledgment Received." is posted to the Search/Fetch Log Card.
Success	0000		The message "Dataset Transfer Completed" posted to the network Log card.
Failed	A900	Identifier does not match SOP Class	The message "Failed to Query Remote DICOM Station" is posted to the Search/Fetch Log Card.
	C000	Unable to process	The message "Remote DICOM station failed to Process Query Request" is posted to the Search/Fetch Log Card.
Pending	FF00	Matches are continuing - Current Match is supplied and any Optional Keys were supported in the same manner as Required Keys.	- No Visible User Output
	FF01	Matches are continuing - Warning that one or more Optional Keys were not supported for existence and/or matching for this Identifier.	A warning message is logged in a log file but is not visible to the operator.

2.2.6.1.3 Association Acceptance Policy

The XELERIS DICOM Server AE places no limitation on whom may connect to it. The XELERIS DICOM Server AE responds to image store operations from remote AE's. Any Remote AE can request and receive a list of images located in the local Xeleris/eNTEGRA database. Any Remote AE can send images (CT/MR/NM/SC/Stand alone Curve/Xeleris/eNTEGRA Private Data) to Xeleris/eNTEGRA to be stored in the local Xeleris/eNTEGRA database.

Any remote AE can open an association to the DICOM Server AE for the purpose of application level communication verification.

The XELERIS DICOM Server AE responds to query requests from remote AE's and responds with matching responses.

Any remote AE can also request the XELERIS DICOM Server AE to retrieve image data from Xeleris/eNTEGRA, and to store this data in the database of the remote AE.

2.2.6.1.3.1 Real-World Activity: Image Storage SCP - Xeleris Application Entity

Associated Real-World Activity

The DICOM Server AE is always listening for associations. No operator action is required to respond to a Store request.

The real-world activity associated with the Store request is to store the image data in the local database and send a C-STORE -RSP message with the status of "success" for each image that can be stored in the local database. A C-STORE-RSP message with the status "failed" is sent for each image that cannot be stored in the local database.

CT, MR, PET, NM images are stored with Full fidelity in Xeleris database.

Accepted Presentation Context Table

Presentation Context Table - Proposed					
Abstract Syntax		Transfer Syntax		Role	Extended Negotiation
Name	UID	Name List	UID List		
Nuclear Medicine Image Storage	1.2.840.10008.5.1.4.1.1.20	Implicit VR Little Endian	1.2.840.10008.1.2	SCP	None
Stand-Alone Curve Storage	1.2.840.10008.5.1.4.1.1.9	Explicit VR Little Endian	1.2.840.10008.1.2.1	SCP	None
Xeleris Private SOP Class Storage	1.2.840.113619.4.27	Implicit VR Little Endian	1.2.840.10008.1.2	SCP	None
Secondary Image Capture Storage	1.2.840.10008.5.1.4.1.1.7	Explicit VR Little Endian	1.2.840.10008.1.2.1	SCP	None
CT Image Storage	1.2.840.10008.5.1.4.1.1.2	Implicit VR Little Endian	1.2.840.10008.1.2	SCP	None
MR Image Storage	1.2.840.10008.5.1.4.1.1.128	Explicit VR Little Endian	1.2.840.10008.1.2.1	SCP	None
PET private RAW data storage	1.2.840.113619.4.30	Implicit VR Little Endian	1.2.840.10008.1.2	SCP	None
		Explicit VR Little Endian	1.2.840.10008.1.2.1		

NOTE :

Xeleris supports level 2 SCP storage.

SOP Specific DICOM Conformance Statement for the STORE SOP Class

Following are the status codes the Application may send back to the SCU Equipment after performing the requested **Store**:

Service Status	Status Codes	Further Meaning	Application Behaviour while receiving Status Codes
Refused	A700	Out of resources	Returned if the DICOM Server runs out of resources (e.g. memory); error logged.
	A710	Out of resources	Dataset not written into the remote database
	A720	Out of resources	Internal error in the DICOM AE
	A730	Out of resources	DICOM AE failed to understand DICOM stream
	A740	Out of resources	DICOM AE failed to access pixel data in the DICOM stream.
Warning	B000	Coercion of Data Elements	Warning! Dataset does not match SOP Class or Coercion of Data Elements
	B007	Data Set does not match SOP Class	Warning! Dataset does not match SOP Class or Coercion of Data Elements
	B006	Elements Discarded	Warning! Dataset does not match SOP Class or Coercion of Data Elements
Success	0000	Image store onto Xeleris is complete.	Returned when the DICOM Server completes the store operation.
Error	A9xx	Dataset does not match SOP Class	Returned by the DICOM Server if for any other reason, not specified elsewhere in this table, the Store operation failed; error logged.

	Cxxx	Cannot Understand	Returned by the DICOM Server if for any other reason, not specified elsewhere in this table, the Store operation failed; error logged.
--	------	-------------------	--

NOTE

The error codes A700-A740 are Xeleris/eNTEGRA Private Status Codes. Xeleris/eNTEGRA stations will return one of the above mentioned status codes (Refused and Error) in case of Image Receive Failure. DICOM PS3.4 provides the flexibility of returning private status codes. Xeleris/eNTEGRA uses them to provide more information to the Xeleris/eNTEGRA user in case of an Image Receive failure.

Presentation Context Acceptance Criterion

The Presentation Context that will be accepted by the DICOM Server will be the one to which the remote Storage SCU has accorded the highest priority and that is supported by the DICOM Server.

Transfer Syntax Selection Policies

A Transfer Syntax that will be selected will be the one to which the remote Storage SCU has accorded the highest priority and that is supported by the DICOM Server.

2.2.6.1.3.2 Real-World Activity: Query SCP - Xeleris Application Entity

Associated Real-World Activity

The DICOM Server AE is always listening for associations. No operator action is required to respond to Query request.

The real-world activity associated with the Query request is to search the local database for all entries that match the request and send a C-FIND-RSP message with the status of “pending” for each matching entry. The exception to this is the last message which is sent with a status of “success.”

Accepted Presentation Context Table

Presentation Context Table - Proposed					
Abstract Context		Transfer Syntax		Role	Extended Negotiation
Name	UID	Name List	UID List		
Patient Root Query/ Retrieve Information Model -	1.2.840.10008.5.1.4.1.2.1.1	Implicit VR Little Endian	1.2.840.10008.1.2	SCP	None
		Explicit	1.2.840.10008.1.2.1		

FIND		VR Little Endian			
Study Root Query/ Retrieve Information Model - FIND	1.2.840.10008.5.1.4.1.2.2.1	Implicit VR Little Endian Explicit VR Little Endian	1.2.840.10008.1.2 1.2.840.10008.1.2.1	SCP	None

NOTE

This implementation does not support extended negotiation for the C-FIND Service, including that for relational-queries.

SOP Specific DICOM Conformance Statement for the Patient Root Query/Retrieve Information Model - Find and Study Root Query/Retrieve Information Model - FIND SOP Classes

Following are the status codes the Application may send back to the SCU Equipment after performing the requested **Query**:

Service Status	Status Codes	Further Meaning	Application Behaviour while receiving Status Codes
Refused	A700	Out of resources	Returned if the DICOM Server runs out of resources (e.g. memory); error logged.
Failed	C000	Unable to process	Returned by the DICOM Server if for any other reason, not specified elsewhere in this table, the Find operation failed; error logged.
Cancel	FE00	Matching terminated due to cancel	Returned if the DICOM Server receives a C-CANCEL-FIND-RQ message; error logged.
Success	0000	Matching is complete - No final identifier is supplied.	Returned when the DICOM Server completes the operation.

Pending	FF00	Matches are continuing - Current Match is supplied and any Optional Keys were supported in the same manner as Required Keys.	
	FF01	Matches are continuing - Warning that one or more Optional Keys were not supported for existence and/or matching for this Identifier	

Presentation Context Acceptance Criterion

The Presentation Context that will be accepted by the DICOM Server will be the one to which the remote Storage SCU has accorded the highest priority and that is supported by the DICOM Server.

Transfer Syntax Selection Policies

A Transfer Syntax that will be selected will be the one to which the remote Storage SCU has accorded the highest priority and that is supported by the DICOM Server.

2.2.6.1.3.3 Real-World Activity: Image Retrieve SCP - Xeleris Application Entity

Associated Real-World Activity

The DICOM Server AE is always listening for associations. No operator action is required to respond to an Image Retrieve request.

The real-world activity associated with the Image Retrieve request is to send all images corresponding to the C-MOVE request to the specified destination AE through a separate association.

Accepted Presentation Context Table

Presentation Context Table - Proposed					
Abstract Context		Transfer Syntax		Role	Extended Negotiation
Name	UID	Name List	UID List		
Patient Root Query/ Retrieve Information Model - MOVE	1.2.840.10008.5.1.4.1.2.1.2	Implicit VR Little Endian Explicit VR	1.2.840.10008.1.2 1.2.840.10008.1.2.1	SCP	None

		Little Endian			
Study Root Query/ Retrieve Information Model - MOVE	1.2.840.10008.5.1.4.1.2.2.2	Implicit VR Little Endian	1.2.840.10008.1.2	SCP	None
		Explicit VR Little Endian	1.2.840.10008.1.2.1		

NOTE

This implementation does not support extended negotiation for the C-MOVE Service, including that for relational-retrieve.

SOP Specific DICOM Conformance Statement for the Patient Root Query/Retrieve Information Model - MOVE and Study Root Query/Retrieve Information Model - MOVE SOP Classes

Following are the status codes the Application may send back to the SCU Equipment after performing the requested **Retrieve**:

Service Status	Status Codes	Further Meaning	Application Behaviour while receiving Status Codes
Refused	A701	Out of resources – Unable to calculate number of matches.	Returned if the DICOM Server can't find requested SOP instance(s); error logged.
	A702	Out of resources – Unable to calculate number of matches.	Returned if the DICOM Server can't find requested SOP instance(s); error logged.
	A801	Out of resources – Unable to calculate number of matches.	Returned if the DICOM Server can't find requested SOP instance(s); error logged.
Failed	A900	Identifier does not match SOP Class	Returned if the DICOM Server receives other than the Patient Root Query/Retrieve Information Model or Study Root Query/Retrieve Information Model SOP class.

	C000	Unable to process	Returned if the DICOM Server cannot successfully interpret the C-MOVE-RQ message.
Cancel	FE00	Sub-operations terminated due to a Cancel indication	Returned if the DICOM Server receives a C-CANCEL-MOVE-RQ message.
Warning	B000	Sub-operations Complete - One or more failures.	Returned upon completion if one or more of the specified images failed to transfer to the destination AE.
Success	0000	Sub-operations Complete - No Failure	Returned after the transfer of the last image.
Pending	FF00	Sub-operations are continuing	Returned after the transfer of each image except for the last.

2.2.6.1.3.4 Real-World Activity: Verify SCP - Xeleris Application Entity

Associated Real-World Activity

The XELERIS DICOM Server AE is always listening for associations. No operator action is required to respond to a Verification request.

The real-world activity associated with the Verification request is to send a C-ECHO-RSP message with a status of “success” to the requesting AE.

Accepted Presentation Context Table

Presentation Context Table - Proposed					
Abstract Context		Transfer Syntax		Role	Extended Negotiation
Name	UID	Name List	UID List		
Verification SOP Class	1.2.840.10008.1.1	Implicit VR Little Endian	1.2.840.10008.1.2	SCP	None

SOP Specific DICOM Conformance Statement for Verification SOP Class

The XELERIS DICOM Server AE provides standard conformance to the DICOM verification service class.

Presentation Context Acceptance Criterion

The Presentation Context that will be accepted by the XELERIS DICOM Server will be the one to which the remote Storage SCP has accorded the highest priority and that is supported by the XELERIS DICOM Server.

Transfer Syntax Selection Policies

A Transfer Syntax that will be selected will be the one to which the remote Storage SCU has accorded the highest priority and that is supported by the DICOM Server.

2.2.6.2 Communication Profiles - Xeleris Application Entity

2.2.6.2.1 Support Communication Stacks (PS 3.8, PS 3.9)

DICOM Upper Layer (PS 3.8) is supported using TCP/IP.

2.2.6.2.2 OSI Stack

The OSI Communication Stack is not supported by this implementation.

2.2.6.2.3 TCP/IP Stack

The TCP/IP Communication Stack is inherited from the UNIX operating system.

2.2.6.2.4 API

Not applicable to this product.

2.2.6.2.5 Physical Media Support

Ethernet 802.3 provides the physical network layer for this product.

2.2.6.2.6 Point-to-Point Stack

The Point-to-Point Communication Stack is not supported by this implementation.

2.2.6.3 Extentions/Privatizations/Specialization - Xeleris Application Entity

2.2.6.3.1 Standard Extended/Specialized/Private SOPs

Xeleris/eNTEGRA NM Images are Standard Extended NM Image Storage SOP Class. Xeleris/eNTEGRA implements a transfer SOP class for full fidelity transfer of protocol data between Xeleris/eNTEGRA systems. The protocol data object conveys information about image processing steps, results data, and display formatting. Protocol data objects are not visible on the Xeleris/eNTEGRA patient selector, but are generally sent automatically with image data if the entire series is selected for transfer. For details of the Xeleris/eNTEGRA Private Protocol Data Object refer to Section 9.

2.2.6.3.2 Private Transfer Syntaxes

Xeleris/eNTEGRA does not implement any private transfer syntaxes.

2.2.6.4 Configurations - Xeleris Application Entity

The Xeleris/eNTEGRA system is configured by GEMS Field Service Engineers. The DICOM configuration items below are configurable or re-configurable by a Field Service Engineer but are not accessible through the Xeleris/eNTEGRA user interface.

2.2.6.4.1 AE Title/Presentation Address Mapping

Xeleris/eNTEGRA allows for the configuration of the mapping of remote AE titles to IP addresses and ports. The IP address of a remote AE may be in a different subnet (using routing). A router is

configurable to ensure communication from one sub-net to another. This configuration is performed by GEMS Field Service Engineers.

2.2.6.4.2 Configuration Parameters

The following parameters are configurable for the DICOM Server AE:

- Local AE Title (set to hostname of Xeleris/eNTEGRA computer)
- Local IP address
- Local DICOM Port Number - to change the port number set the environment variable DCM_PORT

If the variable is not defined, the default port number is used

Note that the default port on which Xeleris/eNTEGRA receives DICOM incoming TCP/IP connections is **104**. The configuration of IP routers and subnet mask is available on a OS level.

2.2.6.5 Support of Extended Character Sets

In addition to the DICOM default character set, *Discovery ST Xeleris DICOM Server AE* supports the ISO IR 100 Latin alphabet #1 supplementary set for the purpose of interchange

2.3 CODES AND CONTROLLED TERMINOLOGY

Discovery ST product uses no coded terminology.

2.4 SECURITY PROFILES

Discovery ST product does not conform to any defined DICOM Security Profiles.

It is assumed that the product is used within a secured environment. It is assumed that a secured environment includes at a minimum:

1. Firewall or router protections to ensure that only approved external hosts have network access to the product.
2. Firewall or router protections to ensure that the product only has network access to approved external hosts and services.

Any communications with external hosts and services outside the locally secured environment use appropriate secure network channels (such as a Virtual Private Network (VPN))

3 MEDIA STORAGE CONFORMANCE STATEMENT

3.1.1 Introduction

This section specifies the Discovery ST conformance to DICOM Media Interchange. It details the DICOM Media Storage Application Profiles and roles, which are supported by this product.

3.1.2 Implementation Model: MOD Archive Server

All DICOM Media functionality on the Discovery ST product is handled by the CT Application Entity (MOD Archive Server). The CT MOD Archive Server AE is commanded to perform DICOM services through the buttons and menu selections on the main user interface panel.

3.1.2.1 Application Data Flow Diagram

The CT MOD Archive Server creates and/or updates the 5.25 inch (130mm) MOD media with various DICOM SOP instances. It can process CT, MR, and Secondary Capture IODs.

**ILLUSTRATION 3-1:
SPECIFIC AE APPLICATION MODEL**

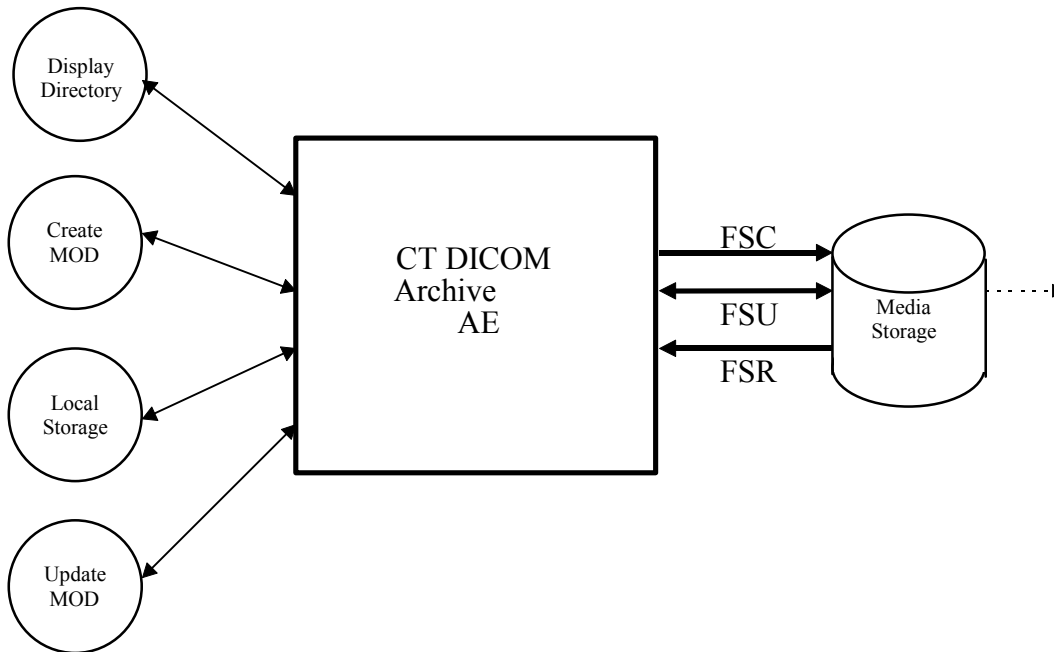

The product has a local storage that may contain various SOP instances. These may have been obtained by original creation, network transfer (DICOM or

proprietary), or by reading removable media from other devices. The origin of SOP instances is outside the scope of this claim.

The MOD Archive Server AE can initialize Media by acting as an FSC to create a new DICOM File-set on a 2.3GB MOD media or a 1.2GB MOD media. It initializes the DICOM File-set and writes the specified SOP instances onto the MOD. The SOP instances written will be limited to instances that match the criteria of one of the Application Profiles that is supported. When updating media, a pre-existing File-set will be updated with the selected SOP instances that match one of the supported Application Profiles.

3.1.2.2 Functional Definitions of AE's

This product has only one media interchange Application Entity: the CT MOD Archive Server AE.

The MOD Archive Server can perform these functions:

- It can initialize (create DOS filesystem) a piece of media, writing a new label and DICOM File-set onto the media. ("LABEL")
- It can update a piece of media by adding new SOP instances to an already existing DICOM File-set from local storage. ("SAVE")
- It can display a directory listing of the File-set on a piece of media. ("QUERY")
- It can copy SOP instance from the MOD onto local storage. ("RESTORE")

3.1.2.3 Sequencing of Real World Activities

The updating function can only be performed on a piece of media that has already had a DICOM File-set created.

The display function can only be performed on a piece of media that has already has a DICOM File-set created. With no SOP instances having been added, the directory will be displayed empty.

The copy function can only be performed with a piece of media that has DICOM SOP instances in the File-set.

There are no other sequencing requirements.

3.1.2.4 File Meta Information for Implementation Class and Version

The File Meta-Information for this implementation is:

File Meta-Information Version	1
Implementation UID	1.2.840.113619.6.55
Implementation Version Name	1.0

3.1.3 AE Specifications

3.1.3.1 MOD Archive Specification

The MOD Archive provides standard conformance to DICOM Interchange Option of the Media Storage Service Class. The Application Profiles and roles are listed in Table 3.1-1.

Table 3.1-1: Application Profile, Activities and Roles for MOD Update

Application Profiles Supported	Real World Activity	Role	SC Option
STD-CTMR-MOD23 AUG-CTMR-MOD23	Create MOD	FSC	Interchange
	Update MOD	FSU	Interchange
	Display Directory	FSR	Interchange
	Copy To Local Storage	FSR	Interchange
STD-CTMR-MOD12 AUG-CTMR-MOD12	Create MOD	FSC	Interchange
	Update MOD	FSU	Interchange
	Display Directory	FSR	Interchange
	Copy To Local Storage	FSR	Interchange
PRI-CTMR-MOD12	Display Directory	FSR	Interchange
	Copy To Local Storage	FSR	Interchange

The MOD Archive Application will query the user before initializing media when a File-set is found on the media and an initialize operation has been requested.

As an FSU role, the system will produce directory sequences for each SOP instance that is added to the File-set consistent with the AUG-CTMR-MOD{12,23} profile and it will make the File-set directory so that an early installed base system that only understands the PRI-CTMR-MOD12 profile will not be able to use the media.

3.1.3.1.1 File Meta Information for the Application Entity

Following are the values set in the File Meta Information for this AE:

Source Application Entity Title	Not used by the MOD Archive Application
Private Information Creator UID	Not used by the MOD Archive Application
Private Information	Not used by the MOD Archive Application

3.1.3.1.2 Real World Activities

3.1.3.1.2.1 Real World Activity: Create MOD Request

The MOD Archive Application acts as an FSC using the Interchange option when requested to initialize (“LABEL”) the media.

The MOD Archive Application will label the media and take the user provided list of SOP instances, eliminating any SOP instances on that list that does not correspond to one of the Application Profiles in Table 3.1-1. These SOP

instances are written to the media and a corresponding DICOMDIR sequence record is created.

Application Profiles for the RWA: Create MOD

The Create MOD RWA applies to the STD-CTMR and AUG-CTMR Application Profiles listed in Table 3.1-1. For extensions and specializations see section 3.1.4.

Options:

Following are the SOP Class, Photometric Interpretation, and Transfer Syntax combinations created by this AE as an FSC/FSU.

Table 3.3.1.2.1.2-1 : IODs and Transfer Syntaxes supported for RWA: Create MOD

SOP Class	SOP Class UID	Photometric Interpretation Value	Transfer Syntax	Transfer Syntax UID
Basic Directory	1.2.840.10008.1.3.10	-	Explicit VR Little Endian Uncompressed	1.2.840.10008.1.2.1
CT Image	1.2.840.10008.5.1.4.1.1.2	MONOCHROME2	JPEG Lossless Process 14 (selection value 1)	1.2.840.10008.1.2.4.70
CT Image	1.2.840.10008.5.1.4.1.1.2	MONOCHROME2	Explicit VR Big Endian	1.2.840.10008.1.2.2
MR Image	1.2.840.10008.5.1.4.1.1.4	MONOCHROME2	JPEG Lossless Process 14 (selection value 1)	1.2.840.10008.1.2.4.70
MR Image	1.2.840.10008.5.1.4.1.1.4	MONOCHROME2	Explicit VR Big Endian	1.2.840.10008.1.2.2
Secondary Capture Image	1.2.840.10008.5.1.4.1.1.7	MONOCHROME2	JPEG Lossless Process 14 (selection value 1)	1.2.840.10008.1.2.4.70
Secondary Capture Image	1.2.840.10008.5.1.4.1.1.7	MONOCHROME2	Explicit VR Big Endian	1.2.840.10008.1.2.2

Notes:

The CT Media Archive Server AE does not support writing images using the Explicit VR Little Endian Transfer Syntax as an FSC/FSU of the STD-CTMR profiles.

The Media Archive Server AE does not support writing Secondary Capture Palette Color images as an FSC/FSU of the STD-CTMR profiles.

The default Transfer Syntax for writing images is JPEG Lossless. Use of Explicit VR Big Endian Transfer Syntax may be configured by a field service engineer.

3.1.3.1.2.2

Real World Activity: Display Directory

The CT MOD Archive Application acts as an FSR using the Interchange option when requested to provide a directory listing.

When an MOD update Application is requested to provide a directory listing it will read the File-set and display the DICOMDIR directory entries for those Series in the File-set that have Modality value of “CT” or “MR”.

Application Profiles for the RWA: MOD Display Directory

The MOD Display Directory RWA applies to all Application Profiles listed in Table 3.1-1. For extensions and specializations see section 3.1.4.

Options:

None applicable.

3.1.3.1.2.3 Real World Activity: Copy to Local Storage

The MOD Archive Application acts as an FSR when copying from the MOD to local storage.

The MOD Archive Application will copy any SOP Instance selected from an MOD Directory list from the MOD to the local storage upon request.

Note:

The MOD Display Directory Real-World Activity will filter out Series that do not match the Modality value of “CT” or “MR”; hence any SOP Instances in non-CT/MR series will not be able to be copied to local storage.

Application Profiles for the RWA: Copy to Local Storage

The MOD Copy to Local Storage RWA applies to all Application Profiles listed in Table 3.1-1. For extensions and specializations see section 3.1.4.

Options:

Following are the SOP Class, Photometric Interpretation, and Transfer Syntax combinations read by this AE as an FSR for copy to local storage.

Table 3.3.1.2.3.2-1 : IODs and Transfer Syntaxes supported for RWA: Copy to Local Storage

SOP Class	SOP Class UID	Photometric Interpretation Value	Transfer Syntax	Transfer Syntax UID
CT Image	1.2.840.10008.5.1.4.1.1.2	MONOCHROME2	Explicit VR Little Endian	1.2.840.10008.1.2.1
CT Image	1.2.840.10008.5.1.4.1.1.2	MONOCHROME2	JPEG Lossless Process 14 (selection value 1)	1.2.840.10008.1.2.4.70
CT Image	1.2.840.10008.5.1.4.1.1.2	MONOCHROME2	Explicit VR Big Endian	1.2.840.10008.1.2.2

MR Image	1.2.840.10008.5.1.4.1.1 .4	MONOCHROME2	Explicit VR Little Endian	1.2.840.10008.1.2.1
MR Image	1.2.840.10008.5.1.4.1.1 .4	MONOCHROME2	JPEG Lossless Process 14 (selection value 1)	1.2.840.10008.1.2.4.70
MR Image	1.2.840.10008.5.1.4.1.1 .4	MONOCHROME2	Explicit VR Big Endian	1.2.840.10008.1.2.2
Secondary Capture Image	1.2.840.10008.5.1.4.1.1 .7	MONOCHROME2	Explicit VR Little Endian	1.2.840.10008.1.2.1
Secondary Capture Image	1.2.840.10008.5.1.4.1.1 .7	MONOCHROME2	JPEG Lossless Process 14 (selection value 1)	1.2.840.10008.1.2.4.70
Secondary Capture Image	1.2.840.10008.5.1.4.1.1 .7	MONOCHROME2	Explicit VR Big Endian	1.2.840.10008.1.2.2

3.1.3.1.2.4 Real World Activity: Update MOD

The MOD Archive Application acts as an FSU using the Interchange option when requested to update an MOD.

The MOD Archive Application will take the selected list of SOP instances and eliminate any SOP instance that does not correspond to permissible SOP instances listed in the Application Profiles Table 3.1-1. The remaining SOP instances are written to the media that is found in the MOD Archive Application disk drive. The determination of the potentially applicable Application Profile is dependent on the type of media and associated software on which the AE has been invoked.

Application Profiles for the RWA: Update MOD Request

The Update MOD Request RWA applies to the STD-CTMR and AUG-CTMR Application Profiles listed in Table 3.1-1. For extensions and specializations see section 3.1.4.

Options:

See Section 3.1.3.1.2.1

3.1.4 Augmented and Private Application Profiles

3.1.4.1 Augmented Application Profiles

3.1.4.1.1 AUG-CTMR-MOD12 and AUG-CTMR-MOD23 Application Profiles

The AUG-CTMR-MOD12 and AUG-CTMR-MOD23 Application Profiles (hereinafter denoted AUG-CTMR) are augmentations of the corresponding STD-CTMR Application Profiles.

3.1.4.1.1.1 SOP Classes and Transfer Syntaxes

The AUG-CTMR Application Profiles add the following SOP Classes and Transfer Syntaxes to the STD-CTMR Profile:

Table 3.4.1.1.1-1 : Additional IODs and Transfer Syntaxes for AUG-CTMR Application Profiles

Information Object Definition	SOP Class UID	Transfer Syntax and UID	FSC Req.	FSR Req.	FSU Req.
CT Image Storage	1.2.840.10008.5.1.4.1.1.2	Explicit VR Big Endian Uncompressed 1.2.840.10008.1.2.2	0	0	0
MR Image Storage	1.2.840.10008.5.1.4.1.1.4	Explicit VR Big Endian Uncompressed 1.2.840.10008.1.2.2	0	0	0
SC Image Storage	1.2.840.10008.5.1.4.1.1.7	Explicit VR Big Endian Uncompressed 1.2.840.10008.1.2.2	0	0	0

3.1.4.1.1.2 Directory Information in DICOMDIR

The modality attribute (0008,0060) value in the DICOMDIR Series records shall be CT or MR.

3.1.4.1.1.3 Other Parameters

Image Attribute Values

The attributes listed in Table 3.3.3.1.5.1-1 used within the Image files shall take the values specified.

Table 3.3.3.1.5.1-1: AUG-CTMR Profiles Required Image Attribute Values

Attribute	Tag	Value
Modality	(0008,0060)	CT/MR
Photometric Interpretation	(0028,0004)	MONOCHROME2
Bits Allocated	(0028,0100)	16
Bits Stored	(0028,0101)	16

Overlay data if present shall be encoded in Overlay Data (60XX,3000).

3.1.4.2 Private Application Profiles

The MOD Archive Server supports a private Application Profile: PRI-CTMR-MOD12 as an FSR.

3.1.4.2.1 PRI-CTMR-MOD12 Private Application Profile

The PRI-CTMR-MOD12 Application Profile specifies the media interchange of CT and MR objects using an improper JPEG compression process. This process, formerly used in some GE products but now retired, resulted in interoperability problems when SOP Instances were decoded using readily available industry decompression routines. In most respects, this profile is identical to the STD-CTMR-MOD12 Application Profile.

3.1.4.2.1.1 Roles and Service Class Options

Since the process that created media with this profile is now retired, the only Role allowed is File-Set Reader.

3.1.4.2.1.2 SOP Classes and Transfer Syntax

The PRI-CTMR-MOD12 Application Profile is defined for the SOP Classes and corresponding Transfer Syntax of the following table:

Table 3.4.2.1.2-1 : IODs and Transfer Syntaxes for PRI-CTMR-MOD12 Application Profile

Information Object Definition	SOP Class UID	Transfer Syntax and UID	FSC Req.	FSR Req.	FSU Req.
CT Image Storage	1.2.840.10008.5.1.4.1.1.2	JPEG Lossless Process 14 (selection value 1) 1.2.840.10008.1.2.4.70	-	○	-
MR Image Storage	1.2.840.10008.5.1.4.1.1.4	JPEG Lossless Process 14 (selection value 1) 1.2.840.10008.1.2.4.70	-	○	-
SC Image Storage	1.2.840.10008.5.1.4.1.1.7	JPEG Lossless Process 14 (selection value 1) 1.2.840.10008.1.2.4.70	-	○	-

Note:

The Transfer Syntax specified in Table 3.4.2.1.2-1 is the one declared in the File Meta-Information Header, but in fact an improper encoding of that Transfer Syntax is used in the image objects. See 3.4.2.1.5.1.

3.1.4.2.1.3 Physical Media and Media Formats

The PRI-CTMR-MOD12 Application Profile requires the 130mm 1.2GB 512 Byte per Sector Magneto-Optical Rewriteable physical media with the PC File System, as defined in PS3.12.

3.1.4.2.1.4 Directory Information in DICOMDIR

The PRI-CTMR-MOD12 Application Profile uses the same Directory Information as the STD-CTMR-MOD12 Profile, except that the Frame of Reference UID (0020,0052) key Attribute of the IMAGE Directory Records is not present.

Notes:

The absence of the Frame of Reference UID Attribute in the IMAGE Directory Record is used by the product as an indication that the referenced SOP Instance has been encoded by the improper JPEG encoder.

3.1.4.2.1.5 Other Parameters

Image Attribute Values

The Pixel Data (7FE0,0010) of SOP Instances stored with Transfer Syntax JPEG Lossless Process 14 (selection value 1), UID 1.2.840.10008.1.2.4.70, are improperly encoded as follows:

- In the JPEG 'SOS' (0xFFDA) header, the entropy coding table selector codes are 0x11. (They should be 0x00.) This is the key indication that the pixel data has been encoded by the improper JPEG encoder.
- The predictor value used at the beginning of each line uses the last value of the previous line in the image. (The JPEG standard says the predictor for the first line element of each line should be the first element of the line immediately above the current line.)
- The computation of the pixel value difference to be entropy encoded is computed as (Predictor - value). (It should be calculated as (value - Predictor).)

3.1.5 Extensions, Specializations and Privatization of SOP Classes and Transfer Syntax

3.1.5.1 Extensions, Specialization's and Privatization's of SOP Classes

The CT/MR SOP Class Images have definitions extended for Defined Terms and include GE specific Private Data elements. The following sections describe the details for these SOP classes.

3.1.5.1.1 SOP Specific Conformance Statement for CT SOP Class

Refer to **section 2.4** for standard extensions and **Appendix B** for private data elements.

3.1.5.1.2 SOP Specific Conformance Statement for MR SOP Class

Refer to **section 2.4** for standard extensions and **Appendix B** for private data elements.

3.1.6 Configuration

The MOD Archive Application may have either a 1.2GB or a 2.3GB drive installed.

Table 3.5-1 : Supported Profiles for various Drive Configurations

Disk Drive Installed	Profiles Supported
1.2GB Optical Disk Drive	PRI-CTMR-MOD12
	STD-CTMR-MOD12
2.3GB-Optical Disk Drive	PRI-CTMR-MOD12
	STD-CTMR-MOD12
	STD-CTMR-MOD23

3.1.7 Support of Extended Character Sets

The MOD Archive Application will support copy of SOP instances containing the ISO IR 100 (Latin alphabet No. 1, supplementary set) and DICOM default character sets as defined in PS3.5.

4 PRINT SCU CONFORMANCE

4.1.1 Introduction

This conformance statement specifies the Discovery ST conformance to the DICOM Print SCU Application Profile. The Discovery ST product uses DICOM Print SCU to print images on DICOM Compliant Printers. CT & MR images can be printed from Discovery ST CT AE. Discovery ST also supports review and print of CT/MR/PET and Fused images from Xeleris Workstation. Refer to “Cedara Hardcopy Server as DICOM Print Management SCU” for more details.

4.1.2 IMPLEMENTATION MODEL : PRINT SCU

The DICOM Print SCU is a DICOM print filter which provides the capability to print images to DICOM printers. The DICOM Print filter acts as an SCU of the DICOM print management SOP class.

4.1.2.1 Application Data Flow Diagram

DICOM print SCU Implementation model

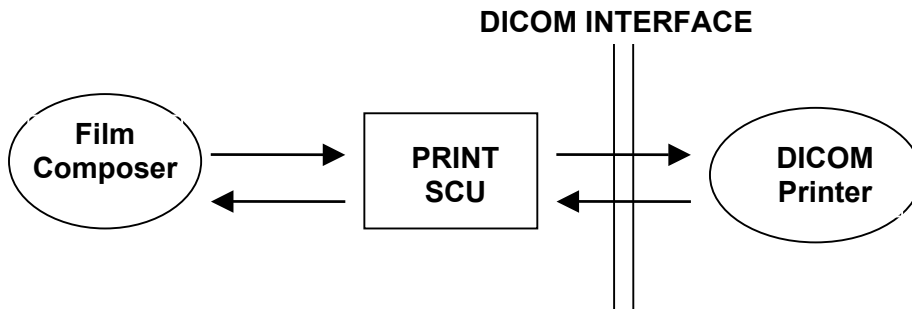

The Film Composer is the User interface and this is used to initiate the local real world activity. The user issues the print request using Film Composer. Film composer allows printer selection and it composes the pre-formatted film file. This film file is interpreted by Print SCU and it sends the appropriate messages to DICOM print SCP running on a DICOM printer.

4.1.2.2 Functional Definition of AE's

DICOM Print SCU Establishes the Association to the requested printer for printing the composed film.

4.1.2.3 Sequencing of Real-World Activities

- The DICOM printer is installed through a camera installation process. The DICOM printer is selected from the Film Composer Interface for Manual Filming. Autofilming is enabled using the camera setup via the camera installation process.
- Images may be acquired for printing in the following manner:
 - Images to be printed may be manually dropped from Viewing applications into the manual film composer slots.
 - Images to be printed may be automatically dropped from Viewing applications into the manual film composer slots.
 - Images to be printed may be manually dropped from Viewing applications into the auto film composer slots.
 - Image series to be printed may be automatically dropped from the PrintSeries application into the manual film composer slots.
 - Images to be printed may be automatically dropped from the Scanning Application into the auto film composer slots.
- Based upon the filming mode (and the attributes) used to acquire images into the film composer, films will be automatically printed when the film session is full, or the user must press the Print Button to print the images.
- The Print SCU retrieves the Print SCP status by using the N-GET service of Printer SOP Class. If the printer returns a FAILURE status the print session will be terminated. The printer status is not read.
- The film session is created using the N-CREATE service. The print session will be terminated if the printer fails to create the film session.
- The film box is created using the N-CREATE service. The print session will be terminated if the printer fails to create the film box.
- The images are placed on the film box by using the N-SET. If the printer fails to place the image on the film box, the print session will be terminated.
- The film will be printed using the N-ACTION. Only film box printing is supported. If the printer fails to print the film, the print session will be terminated.
- After the successful N-ACTION, the film box will be deleted using the N-DELETE. Any N-EVENT-REPORTS given to the PRINT SCU will be received but the data is ignored. After the film box is deleted, the association will be closed.
- Upon the successful completion of the above sequencing and the association is closed, the user will be notified of the successful print session.

4.1.3 AE SPECIFICATIONS

4.1.3.1 DICOM Print SCU AE Specification

Print SCU provides Standard Conformance to the following DICOM SOP classes as an SCU:

SOP CLASS name	SOP CLASS UID
Basic grayscale print management meta SOP class	1.2.840.10008.5.1.1.9
Print Job SOP class	1.2.840.10008.5.1.1.14

4.1.3.1.1 Association Establishment Policy

4.1.3.1.1.1

General

The Film Composer provides options to indicate the printer AE title and Printer host name. These parameters are used by the Print SCU to establish the association with the desired printer.

The DICOM Application Context Name (ACN), which is always proposed, is:

Application Context Name	1.2.840.10008.3.1.1.1
---------------------------------	------------------------------

The Maximum Length PDU negotiation is included in all association establishment requests. The maximum length PDU for association initiated by the DICOM Print SCU AE is:

Maximum Length PDU	16 Kbytes
---------------------------	------------------

4.1.3.1.1.2

Number of Associations

The Print SCU will initiate only one association with printer. Multiple associations are not supported.

4.1.3.1.1.3

Asynchronous Nature

The print SCU does not support asynchronous operations. All operations will be performed synchronously.

4.1.3.1.1.4

Implementation identifying information

The Implementation UID allows unique identification of a set of products that share the same implementation.

The Implementation UID for this ID/Net v3.0 Implementation is:

Discovery ST Implementation UID	1.2.840.113619.6.55
--	----------------------------

4.1.3.1.2

Association Establishment Policy

Print SCU initiates the association with the Printer.

4.1.3.1.2.1

Real World Activity

Associated Real-World Activity - "Print"

The Film Composer allows the user to select printers and it also allows the user to drag and drop the images (from the viewer application) into the film. It also allows the user to manipulate some print parameters like film format and number of copies to print. When the user presses the "Print" Button, the Film composer communicates this request to Print SCU which then tries to establish the association with the requested printer and transmits the images for printing.

Proposed Presentation Contexts

The Proposed Presentation Context Table for the Print SCU is as shown in following Table.

Presentation Context Table – Proposed					
Abstract Syntax		Transfer Syntax		Role	Extended Negotiation
Name	UID	Name	UID		
Basic Grayscale Print Management Meta SOP Class	1.2.840.10008.5.1.1.9	DICOM Implicit VR Little Endian Transfer Syntax	1.2.840.10008.1.2	SCU	None
Verification SOP Class	1.2.840.10008.1.1	DICOM Implicit VR Little Endian Transfer Syntax	1.2.840.10008.1.2	SCU	None
Printer SOP Class	1.2.840.10008.5.1.1.16	DICOM Implicit VR Little Endian Transfer Syntax	1.2.840.10008.1.2	SCU	None
Print Job SOP Class	1.2.840.10008.5.1.1.14	DICOM Implicit VR Little Endian Transfer Syntax	1.2.840.10008.1.2	SCU	None

Note: Certain Presentation Contexts may be negotiated that are not used during the association. See the following sections for the DICOM Print services performed by the Discovery ST.

4.1.3.1.2.2 SOP Specific Conformance Statement

The Print SCU supports the following mandatory SOP classes which are defined under the Basic Grayscale Print Management Meta SOP Class.

The Print SOP Classes supported by Print SCU :

NAME	UID
Basic Film Session SOP Class	1.2.840.10008.5.1.1.1
Basic Film Box SOP Class	1.2.840.10008.5.1.1.2
Basic Grayscale Image Box SOP	1.2.840.10008.5.1.1.4
Printer SOP Class	1.2.840.10008.5.11.16

The Print SCU does not support any optional SOP Classes.

Note: The asterisk (*) preceding some of the SOP attributes in the following sections indicates optional SCP attributes. The SCU is aware of these optional attributes and will not fail on the receipt of a response without the optional attributes; the limitation being that this information is not available for the User. Some SCP's will terminate the association with a failure upon the receipt of an optional attribute it does not support.

Basic Film Session SOP Class

The Print SCU supports the following DIMSE Service Elements for the Basic Film Session SOP Class.

N-CREATE - Requests the Print SCP to create an instance of Basic Film Session.

The following Attribute values are supported by the N-CREATE:

Attribute	DICOM Tag	Valid Range	Default Value
* Number of Copies	(2000, 0010)	1-99	Set by user
* Print Priority	(2000, 0020)	HIGH / MED / LOW	Set in Configuration file (Default value is HIGH)
* Medium Type	(2000, 0030)	CLEAR FILM BLUE FILM PAPER	Set in Configuration File
* Film Destination	(2000, 0040)	MAGAZINE PROCESSOR	Set in Configuration File

Note: * denotes that the attribute is optional for the SCU. However, we do provide values for all of these optional attributes and if the SCP does not support the requested value it may choose to either return a failure status or ignore the value provided and use its default value.

If Failure status is returned during N-CREATE operation of Film session the following action will be taken by Print SCU:

0x213 "Resource Limitation" message will be sent.

All other status "Failure" message will be sent.

In all the cases the print session will be terminated.

Basic Film box SOP Class

The Print SCU supports the following DIMSE Service Elements for the Basic Film Box SOP Class.

N-CREATE - Requests the Print SCP to create an instance of Film Box.

N-ACTION - Requests the Print SCP to print the Film Box onto Printer.

N-DELETE - Requests the Print SCP to delete the Film Box Instance.

The Following Attribute values are supported:

Attribute	DICOM Tag	Valid Range	Default Value
Image Display Format	(2010, 0010)	STANDARD/C,R Printer Dependent	Set in User Interface
Reference Film Session Sequence	(2010, 0500)		
*Film Orientation	(2010, 0040)	PORTRAIT	Set in Configuration File
Film Size ID	(2010, 0050)	Sent zero length	Sent zero length
*Magnification type	(2010, 0060)	BILINEAR CUBIC REPLICATE	Set in Configuration File

		NONE	
*Max Density	(2010, 0130)	0-4095	Set in Configuration File
Configuration Information	(2010, 0150)	Printer Dependent	Set in Configuration File
*Smoothing type	(2010, 0080)	Printer Dependent	Set in Configuration File
*Border density	(2010, 0100)	BLACK WHITE	Set in Configuration File
*Empty image density	(2010, 0110)	BLACK WHITE	Set in Configuration File
*Min density	(2010, 0120)	0-4094	Set in Configuration File
*Trim	(2010, 0140)	NO	NO

Note: Attributes “sent zero length” use the camera default values.

Note: * denotes that the attribute is optional for the SCU. However, we do provide values for all of these optional attributes and if the SCP does not support the requested value it may choose to either return a failure status or ignore the value provided and use its default value.

If Failure status is returned during N-CREATE operation of Film box following action will be taken by Print SCU.

0x213 “Resource Limitation” message will be sent.

0x106 “Unsupported Film Format” message will be sent.

All other status “Failure” message will be sent

In all the cases the print session will be terminated.

If Failure status is returned during N-ACTION operation of Film box following action will be taken by Print SCU.

0xC602 “Unable to Create Print Job” message will be sent.

All other status “Failure” message will be sent.

In all the cases the print session will be terminated.

If Failure status is returned during N-DELETE operation of Film box following action will be taken by Print SCU.

All the return status “Failure” message will be sent and the print session will be terminated.

Basic Grayscale Image Box SOP Class

The Print SCU supports the following DIMSE Service Elements for Grayscale Image Box SOP Class.

N-SET - Requests the Printer to set the image box attributes.

The Following Attribute values are supported:

Attribute	DICOM Tag	Valid Range	Default Value
Image Position	(2020, 0010)	Based on Image Display Format	No Default Value
Pre-formatted Grayscale Image Sequence	(2020, 0110)		
>Samples per pixel	(0028, 0002)	1	1
>Photometric Interpretation	(0028, 0004)	MONOCHROME2	MONOCHROME2
>Rows	(0028, 0010)	Image Dependent	Image Dependent
>Columns	(0028, 0011)	Image Dependent	Image Dependent
>Pixel Aspect Ratio	(0028, 0034)	1/1	1/1
>Bits Allocated	(0028, 0100)	8	8
>Bits Stored	(0028, 0101)	8	8
>High Bit	(0028, 0102)	7	7
>Pixel Representation	(0028, 0103)	0 (unsigned integer)	0 (unsigned integer)
*Polarity	(2020, 0020)	NORMAL	NORMAL

Note: * denotes that the attribute is optional for the SCU. However, we do provide values for all of these optional attributes and if the SCP does not support the requested value it may choose to either return a failure status or ignore the value provided and use its default value.

If Failure status is returned during N-SET operation of Image Box following action will be taken by Print SCU.

0xC605 "Resources temporarily not available" message will be sent.

All other status "Failure" message will be sent.

In all the cases the print session will be terminated.

Printer SOP Class

N-GET DIMSE service is supported for the Printer SOP Class. If an N-EVENT-REPORT DIMSE service is received when the association is active, Print SCU handles the relevant states but the data received is ignored.

Print SCU issues the request to retrieve the following attributes:

Optional Attribute	DICOM Tag	Default Value
Printer Status	(2110, 0010)	Printer shall return Value
Printer Status Info	(2110, 0020)	Printer shall return Value
Printer Name	(2110, 0030)	Printer shall return Value
Manufacturer	(0008, 0070)	Printer shall return Value
Manufacturer Model Name	(0008, 1090)	Printer shall return Value
Device Serial No.	(1800, 1000)	Printer shall return Value
Software Versions	(1800, 1020)	Printer shall return Value
Date Last Calibrated	(1800, 1200)	Printer shall return Value
Time Last Calibrated	(1800, 1201)	Printer shall return Value

The Print SCU issues the N-GET service to retrieve the printer status. The status is processed as follows:

- If Printer status (2110, 0010) is NORMAL, the film is printed.
- If Printer status (2110, 0010) is FAILURE, the print job is terminated. The Printer Status Info (2110, 0020) attribute is not processed.
- If Printer status (2110, 0010) is WARNING, one of three things will happen:
 - a) If the Printer Status Info (2110, 0020) is “SUPPLY LOW” the status is displayed to the user and the print job continues.
 - b) If the Printer Status Info (2110, 0020) is “RECEIVER FULL” or “SUPPLY EMPTY” or “FILM JAM” the status is displayed to the user and the print job is aborted.
For all other Printer Status Info (2110, 0020) values, the status is ignored and the print job continues.

Print Job SOP Class

Print SCU looks for following attributes in N-EVENT REPORT data received from Print SCP. If Print SCU does not receive N-EVENT_REPORT it requests the Print SCP to retrieve the following set of attributes using N-GET .

Attribute Name	DICOM Tag	Default Value
Execution Status	(2100, 0020)	Value returned by Print SCP
Execution Status info	(2100, 0030)	Value returned by Print SCP
Print Priority	(2000, 0020)	Value returned by Print SCP
Creation Date	(2100, 0040)	Value returned by Print SCP
Creation Time	(2100, 0050)	Value returned by Print SCP
Printer Name	(2110, 0030)	Value returned by Print SCP
Originator	(2100, 0070)	Value returned by Print SCP

4.1.3.1.3 Association Acceptance Policy

The Print SCU does not accept associations.

4.1.4 COMMUNICATION PROFILES

4.1.4.1 Supported Communication Stacks (parts 8,9)

DICOM Upper Layer (Part 8) is supported using TCP/IP.

4.1.4.1.1 TCP/IP Stack

The TCP/IP stack is inherited from the UNIX Operating System.

4.1.4.1.1.1 API

Not Applicable

4.1.4.1.1.2 Physical Media Support

Ethernet v2.0, IEEE 802.3.

4.1.5 Standard Extended/Specialized/Private SOPs

None.

4.1.6 Configuration**4.1.6.1 AE Title/Presentation Address Mapping**

The Local AE title is "hostname_DCP", where "hostname" is the unique hostname within the network.

The Discovery ST system allows the user to "add", "Remove", or "Update" the mapping of remote DICOM Printer AE Titles to IP Addresses and Ports. These options can be selected from the Service Desktop camera installation utility.

4.1.6.2 Configurable Parameters

The following fields are configurable for the DICOM Print SCU AE:

Note: All configurations should be performed by a GE Field Service Engineer.

- Local IP Address
- Local IP Netmask
- Max PDU length

- The following DICOM print parameters are configurable. The valid ranges are shown in earlier sections of this conformance statement.
 - Medium Type (2000, 0030)
 - Film Destination (2000, 0040)
 - Magnification Type (2010, 0060)
 - Min Density (2010, 0120)
 - Max Density (2010, 0130)
 - Empty Image Density (2010, 0110)
 - Border Density (2010, 0100)
 - Configuration Information (2010, 0150)
 - Smoothing Type (2010, 0080)
- The following network timers are supported and are configurable. When these timers expire the association is terminated. The default values are:
 - Association Time out = 600 seconds
 - Session Time out = 3000 seconds (total time for open association)
 - N-SET Time out = 300 seconds
 - N-ACTION Time out = 300 seconds
 - N-CREATE Time out = 300 seconds
 - N-DELETE Time out = 300 seconds
 - N-GET Time out = 100 seconds
- Time-outs, which are set for all hosts, are configurable in dprint.cfg:
 - *Association time-out - *bi_assoc_tio*
 - *Session timeout - *bi_session_tio*
 - *Create timeout - *bi_ncreate_tio*

Note: All configurations are performed by a GE Field Service Engineer.

4.1.7 Support of Extended Character Set

The Print SCU does not support any Extended Character Set.

5 Storage Commitment Conformance

5.1.1 Introduction

This section of the DICOM conformance statement specifies Discovery ST compliance to the Storage Commitment Push Model SOP Class. The CT DICOM Application Entity handles all the Storage Commitment DICOM functionalities. DST CT AE supports Storage Commitment of CT, MR and Secondary Capture for images born on CT. The DST PET and Xeleris do not support Storage Commitment.

5.1.2 Implementation Model

5.1.2.1 Application data flow diagram

Illustration 5-0 is a subset of Illustration 2-0 showing the data flow diagram for Storage Commitment.

ILLUSTRATION 5-0

APPLICATION DATA FLOW DIAGRAM

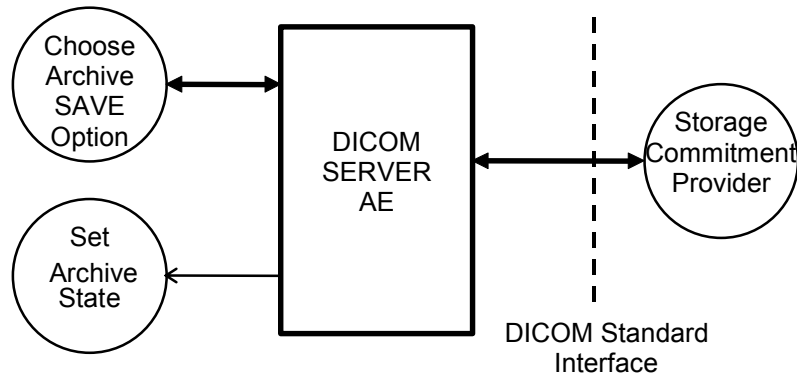

There is only one Real-World activity that will cause the CT DICOM Server Application Entity (CT DICOM Server AE) to initiate an association to a remote DICOM entity that is a Service Class Provider (SCP) of the Storage Commitment SOP class.

The *Choose Archive save Option* Real-World activity consists of an operator choosing a remote DICOM AE that supports Storage Commitment as provider as the archive device and selecting one or more exam or series from the local database and choosing either *Save Exam* or *Save Series* from the archive menu. The images to be committed are sent to the remote provider entity first. The Commitment request for the transferred image instances is sent after the complete image transfer. The Commitment response can come on same association or on a different association.

The Real-World activity *Set Archive State* is performed by the CT DICOM Server AE to respond to an incoming Storage Commitment response from the remote Storage Commitment Provider.

5.1.2.2 Functional definitions

The CT DICOM Server AE initiates the following operations:

- Negotiates and establishes association with remote Storage Commitment Provider
- Sends the selected images to the remote DICOM AE.
- Closes the association.
- If all the images are transferred without failures the following steps will be executed. If there are any failures the job will be marked as failed and the Storage Commitment request will not be sent.
- Establishes a new association for sending the commitment request. Here note that a storage Commitment request does not imply that the acquisition of images is complete.
- Receives the response on same association or on a different association.
- Updates the archive flag information for successful instances. The archive flag is shared with the local archive and the two can not be distinguished.

5.1.2.3 Sequencing of real-world activities

The user has to select the remote commitment provider and the exams/series to be pushed before clicking Save Exam/Series button on the Archive menu.

5.1.3 AE Specifications

5.1.3.1 DICOM Server AE specifications

In addition to the SOP Classes defined in Section 2.2.4.1, the CT DICOM Server AE provides Standard Conformance to the following SOP class as an SCU:

SOP class name	SOP class UID
Storage Commitment Push model SOP class	1.2.840.10008.1.20.1

5.1.3.1.1 Association establishment policies

The association establishment policies for the CT DICOM Server AE are described in Section 2.2.4.1.1.1

5.1.3.1.2 Association initiation policy

An association is initiated by the Storage SCU to the Service Provider, to send the images to be committed. A separate association is established to send the commitment request.

5.1.3.1.3 Real World Activity

5.1.3.1.3.1 Associated Real World Activity - "Save exam/series"

See Section 2.2.4.1.1.2. The user selects the exam/series to be archived. All the images currently in the selected exam/series will be sent to the selected remote archive node (which is also the Storage commitment SCP) using DICOM C-STORE operations. Once all the images are transferred the commitment request will be sent on a separate association.

5.1.3.1.3.2 Associated Real World Activity - "Auto Archive exam/series"

The Auto archive API's are used to archive the exams/series onto local archive media or the remote archive node (which shall be a Storage Commitment SCP) without manual interface. If the default device selected for Auto Archive is a remote Storage Commitment SCP then all the images currently in the specified exam/series will be sent to the selected Storage commitment SCP using C-STORE operations. On successful transfer of all the images the Storage Commitment request will be sent.

5.1.3.1.4 Proposed Presentation Contexts

The Proposed Presentation Context table for the DICOM Storage Commitment SCU is as shown in following Table.

Presentation Context Table					
Abstract Syntax		Transfer Syntax		Role	Extended Negotiation
Name	UID	Name	UID		
Storage Commitment Push Model	1.2.840.10008.1.20.1	DICOM Implicit VR Little Endian	1.2.840.10008.1.2	SCU	None

The Storage Commitment SCU can send the commitment request for following DICOM SOP classes.

NAME	UID
CT Image Storage SOP Class	1.2.840.10008.5.1.4.1.1.2
MR Image storage SOP Class	1.2.840.10008.5.1.4.1.1.4
Secondary Capture Storage SOP Class	1.2.840.10008.5.1.4.1.1.7

5.1.3.1.5 Request Processing

The images in the selected exam/series are sent to the remote commitment provider entity using DICOM C-STORE operations. If there are any failures in the image transfers the Storage commitment request will not be sent. The corresponding job will be marked as failed and user will be notified of the status of job.

If all the images are successfully transferred then the commitment request will be sent on a different association with the list of sop instances.

If the N-Action request fails, the job will be marked as failed otherwise following sequence of actions will take place.

The SCU waits for **N-Action-Rsp** from provider on the same association for a configurable amount of time. If it does not receive **N-Action-Rsp** during this time it will close the association. It changes the Job state to "Wait" indicating the job is waiting for the response from commitment provider. The job will be marked as failed if the response is not received by **stop job time**. Stop job time is the maximum duration the job can wait for responses.

A New transaction uid will be created for each retry by user. The old transaction uid is not applicable for these requests.

The Following DIMSE service Elements are supported for the Storage Commitment request and response processing.

N-ACTION - Requests the remote Storage Commitment SCP to commit to storing the image instances.

N-EVENT-REPORT - The response sent by the remote Storage Commitment SCP.

The following attributes are sent as part of the **DATA Set** for the **N-Action request**.

Attribute	Tag	Value
Transaction UID	(0008,1195)	Transaction UID
Referenced SOP Sequence	(0008,1199)	
>SOP Class UID	(0008,1150)	
>SOP Instance UID	(0008,1155)	

- Referenced Study Component sequence attribute is not sent.
- Storage Media File-Set ID and Storage Media File-Set UID attributes are not supported.

5.1.3.1.6 Response Processing

Once the N-EVENT REPORT response is received, the following actions will be taken depending on the status of response.

5.1.3.1.6.1 Commit response with SUCCESS status

The Archive flag information in the browser for all the successful instances will be updated. The status will be changed to "Y" .

The job queue entry will be removed

Note :

- The following attributes are expected as part of **DATA Set** for **N-Event-Request** from SCP

Attribute	Tag	Value
-----------	-----	-------

Transaction UID	(0008,1195)	Value received from SCP
Referenced SOP Sequence	(0008,1199)	Value received from SCP
>SOP Class UID	(0008,1150)	Value received from SCP
>SOP Instance UID	(0008,1155)	Value received from SCP

N-Event-Response will be sent on the same association itself. No DATA Set will be sent along with the response.

5.1.3.1.6.2 Commit response with FAILURE status

The following attributes are expected as part of **DATA Set** for **N-Event-Request** from SCP

Attribute	Tag	Value
Transaction UID	(0008,1195)	Value received from SCP
Failed SOP Sequence	(0008,1199)	Value received from SCP
>SOP Class UID	(0008,1150)	Value received from SCP
>SOP Instance UID	(0008,1155)	Value received from SCP
>Failure Reason	(0008,1197)	Value received from SCP

In case of complete/partial failure the user will be notified about the status and the job entry will be paused. There is no attempt made to retry automatically the failed sop instances. However the user can manually retry the failed jobs. Such requests will be treated as new requests. This will go through the whole sequence of operations once again.

The failure reason is ignored.

Failed SOP instances will have their archive flag information unaltered.

Note :

The archive status flag in the browser is a shared flag with local archive. When the status is “Y”, it means that the images are archived but doesn’t specify whether on local archive device or remote archive device. It is left to the user’s discretion whether the local sop instances (with their archive flag set to “Y”) are to be deleted.

N-Event-Response will be sent on the same association itself. No DATA Set will be sent along with the response.

5.1.3.1.7 Association Acceptance Policy

A single association will be accepted at any time to receive Storage Commitment responses.

6 Modality Work List Conformance

6.1.1 INTRODUCTION

This section of the DICOM Conformance Statement specifies the Discovery ST compliance to DICOM conformance requirements for the Modality Worklist features on this GEMS product.

The Modality Worklist Service, provided by Connect Pro option for Discovery ST, allows a user to query for and display DICOM modality worklist information from a remote hospital or radiology department information system computer. For example, a user may wish to query for all procedures scheduled to be performed on the scanner. In this situation, Modality Worklist is providing the DICOM C-FIND service as a service class user (SCU).

6.1.2 IMPLEMENTATION MODEL

All the Modality Worklist DICOM functionality provided by the Discovery ST product is logically provided by the CT DICOM Server AE (Worklist Server). The CT Worklist Server DICOM AE is commanded to perform DICOM modality worklist query services through the use of the Discovery ST user interface.

6.1.2.1 Application Data Flow Diagram

ILLUSTRATION 6-0

MODALITY WORKLIST DATA FLOW DIAGRAM

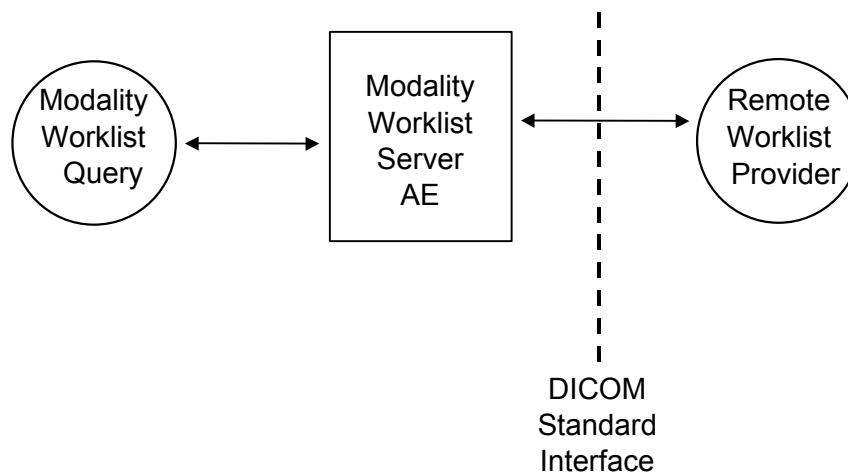

6.1.2.2 Functional definitions

The CT DICOM ModalityWorklist Server AE is implemented as an application process on the scanner host computer. It runs as a daemon serving requests from the user interface to obtain modality worklists, query remote AE's and return the results to the user interface.

The ModalityWorklist Worklist Server AE initiates the following functions:

- *Query*: Initiates a DICOM association in order to query a remote AE. If the remote AE accepts a presentation context applicable to modality worklist, the Worklist Server AE will issue a modality worklist query request via the C-FIND service.

6.1.2.3 Sequencing of Real-World Activities

1. The user or the system initiates a modality worklist query (as a modality worklist SCU) to the Modality Worklist SCP with a given set of query parameters.
2. The Modality Worklist SCP returns responses, which match the query parameters.
3. Items from the returned worklist responses are presented to the user.
4. A subset of the returned worklist responses is included in acquired DICOM images related to the responses.

6.1.3 AE SPECIFICATIONS

6.1.3.1 Worklist Server AE Specification

This Application Entity provides Standard Conformance to the following DICOM SOP Classes as an **SCU**:

SOP Class Name	SOP Class UID
Modality Worklist Information Model - FIND	1.2.840.10008.5.1.4.31

6.1.3.1.1 Association Establishment Policies

6.1.3.1.1.1 General

The DICOM Application Context Name (ACN), which is always proposed, is:

Application Context Name	1.2.840.10008.3.1.1.1
--------------------------	-----------------------

The Maximum Length PDU negotiation is included in all association establishment requests. The maximum length PDU for an association initiated by the DICOM Worklist Server is:

Maximum Length PDU	50 Kbytes
--------------------	-----------

The SOP Class Extended Negotiation is not supported.

The maximum number of Presentation Context Items that will be proposed is 1.

6.1.3.1.1.2 Number of Associations

The CT DICOM Worklist Server AE (SCU) will initiate only one DICOM association at a time to perform a modality worklist query of a single remote AE.

6.1.3.1.1.3 Asynchronous Nature

Asynchronous mode is not supported. All operations are performed synchronously.

6.1.3.1.1.4 Implementation Identifying Information

The Implementation UID for this DICOM Implementation is:

ModalityWorklist for Discovery ST Implementation UID	1.2.840.113619.6.50
--	---------------------

6.1.3.1.2 Association Initiation Policy

The Worklist Server AE initiates a new association due to an update operation being initiated from the Discovery ST user interface.

6.1.3.1.2.1 Real-World Activity: Worklist Query

Associated Real-World Activity

The operator of the system initiates a query for a Modality Worklist by either opening the Schedule screen or by opening the Schedule screen and pressing the Update button. The choice of which of these two behaviors occurs is user configurable. The Worklist Server will then initiate an association with the remote AE in order to query for the worklist.

A user can configure a number of parameters which directly control the worklist query request. The user can request worklist items that are intended for the scanner the user is working at, all items that apply to the modality of the scanner the user is working at or all worklist items available. These selections and their affects on worklist query parameters are given below:

This Scanner:

- Modality, (0008,0060) - set to CT
- Scheduled Station AE Title, (0040,0001) - set to local AE title

This Modality:

- Modality, (0008,0060) - set to CT
- Scheduled Station AE Title, (0040,0001) - zero-length (universal matching)

All Scanners:

- Modality, (0008,0060) - zero-length (universal matching)
- Scheduled Station AE Title, (0040,0001) - zero-length (universal matching)

The scheduled dates of procedures of interest can be specified for query by selecting a specific date range. The date ranges available are Today, Days Before Today, Days After Today and All Days. These selections and their affects on worklist query parameters are given below:

Today:

Scheduled Procedure Step Start Date (0040,0002) - set to YYYYMMDD, where this date is the current date.

Days Before Today and Days After Today:

Scheduled Procedure Step Start Date (0040,0002) - set to YYYYMMDD-YYYYMMDD, where this date range represents the

specified number of days before today and/or after today. Note that number of days both before and after can be specified in the same query and that each always includes today.

All Days:

Scheduled Procedure Step Start Date (0040,0002) - zero-length (universal matching)

Proposed Presentation Context Table

The following table shows the proposed presentation contexts for the Worklist Server AE after real-world activity “Worklist Query” has been initiated:

Presentation Context Table - Proposed					
Abstract Syntax		Transfer Syntax		Role	Extended Negotiation
Name	UID	Name List	UID List		
Modality Worklist Information Model – FIND	1.2.840.10008.5.1.4.31	Implicit VR Little Endian	1.2.840.10008.1.2	SCU	None

SOP Specific DICOM Conformance Statement for the Worklist SOP Class

If the remote AE does not support the proposed Presentation Context, an appropriate error is logged and the operator is notified.

This implementation can receive multiple C-FIND results over a single association. Only one association is opened at a time.

Each C-FIND response received from the remote AE is parsed to verify the length/type of the items in the response (see section 2.2.4.1.1.2 for more information). Upon detecting any error in the response data, the Worklist Server AE will issue a C-FIND-CANCEL and, upon receipt of a C-FIND-RSP (or if an applicable timer expires), will abort the association. All previously received worklist items are retained.

On receipt of any error from the remote AE, the Worklist Server will issue a C-FIND-CANCEL and, upon receipt of a C-FIND-RSP (or if an applicable timer expires), will abort the association. All previously received worklist items are retained. Warnings received from the remote AE are ignored.

Each C-FIND operation supports a configurable “Association Timer.” This timer starts when the association request is sent or received and stops when the association is established. The default time-out value is 30 seconds.

Each C-FIND operation supports a configurable “Session Timer.” This timer starts when an association is established and stops when the association is ended. The default time-out value is 3600 seconds.

If any of the above timers expires, the association is aborted (A-ABORT) and the operation in progress is considered to be failed. Any previously received worklist items are discarded.

Record Acceptance Policy

The Discovery ST implementation adheres to strict value checking of incoming query responses from the remote AE. Each response received is examined to verify that all Type 1 attributes are present with non-zero length, that all Type 2 attributes are present (possibly with zero length) and that the data for all attributes is consistent with respect to the attributes' value representation (VR).

Any inconsistencies in the response data, with respect to the categories described above, are considered errors. Upon detecting any such errors in the response data, the Worklist Server AE will issue a C-FIND-CANCEL and, upon receipt of a C-FIND-RSP (or if an applicable timer expires), will abort the association. All previously received worklist items are retained. Note that the absence of requested Type 3 attributes is not considered an error.

Fields considered Type 1 by the Worklist Server include:

- . (0010,0010), Patient Name
- . (0010,0020), Patient ID
- . (0020,000D), Study Instance UID
- . (0040,0001), Scheduled Station AE Title
- . (0040,0002), Scheduled Procedure Step Start Date ¹
- . (0040,0003), Scheduled Procedure Step Start Time ¹
- . (0040,0009), Scheduled Procedure Step ID
- . (0040,1001), Requested Procedure ID

¹ Start Date must be of the form YYYYMMDD, exactly eight numeric characters, and Start Time must be of the form HHMMSS, exactly six numeric characters.

Fields considered Type 2 by Worklist Server include:

- . (0008,0050), Accession Number
- . (0008,0060), Modality
- . (0008,0090), Referring Physician Name
- . (0010,0030), Patient Date of Birth
- . (0010,0040), Patient Sex
- . (0010,1030), Patient Weight in kg
- . (0010,2000), Medical Alerts
- . (0010,2110), Contrast Allergies
- . (0010,21C0), Pregnancy Status
- . (0032,1032), Requesting Physician
- . (0032,1070), Requested Contrast Agent
- . (0038,0010), Admission ID
- . (0038,0050), Special Needs
- . (0038,0300), Current Patient Location
- . (0038,0500), Patient State
- . (0040,0006), Performing Physician
- . (0040,0010), Scheduled Station Name
- . (0040,0011), Scheduled Procedure Step Location
- . (0040,0012), Pre-order Medication
- . (0040,1003), Requested Procedure Priority

- . (0040,1004), Patient Transport Arrangements
- . (0040,3001), Confidentiality Constraint

6.1.3.1.3 Association Acceptance Policy

The Worklist Server AE does not respond to attempts by a remote AE to open an association.

6.1.4 COMMUNICATION PROFILES

6.1.4.1 Supported Communication Stacks (PS 3.8, PS 3.9)

DICOM Upper Layer (PS 3.8) is supported using TCP/IP.

6.1.4.2 OSI Stack

The OSI Communication Stack is not supported by this implementation.

6.1.4.3 TCP/IP Stack

The TCP/IP Communication Stack is inherited from the IRIX operating system.

6.1.4.3.1 API

Not applicable to this product.

6.1.4.3.2 Physical Media Support

Ethernet 802.3 provides the physical network layer for this product.

6.1.4.4 Point-to-Point Stack

The Point-to-Point Communication Stack is not supported by this implementation.

6.1.5 EXTENSIONS / SPECIALIZATIONS / PRIVATIZATIONS

6.1.5.1 Standard Extended /Specialized/Private SOPs

ModalityWorklist for Discovery ST does not implement any private transfer SOP classes.

6.1.5.2 Private Transfer Syntaxes

ModalityWorklist for Discovery ST does not implement any private transfer syntaxes.

6.1.6 CONFIGURATION

The ModalityWorklist feature is configured by GEMS Field Service engineers. The DICOM configuration items below are configurable or re-configurable by a Field Service Engineer and are not accessible by users through the Discovery ST user interface.

6.1.6.1 AE Title/Presentation Address Mapping

ModalityWorklist allows for the configuration of the following parameters which pertain to the remote AE.

- Remote AE (HIS/RIS) IP address - IP address used to contact the remote AE
- Remote AE (HIS/RIS) IP port - IP port used to contact the remote AE

These parameters define where worklist queries will be directed. Configuration of these parameters is performed by GEMS Field Service engineers using the ModalityWorklist installation facilities.

6.1.6.2 Configurable Parameters

The following parameters are configurable for the DICOM Worklist Server AE:

- Local (Worklist Server) AE Title (automatically set to host name of scanner)
- Local IP address
- Local IP netmask
- Local IP gateway

The following parameters are configurable by changing their values in the configuration file **/usr/g/config/WLdcm.cfg**. Note that these parameters typically need not be changed. Furthermore, no support is provided for retaining changed settings: the values will require changing again after a system software upgrade.

- Implementation UID
- PDU size
- Association time-out period
- Session time-out period
- C-FIND time-out period

6.1.7 SUPPORT OF EXTENDED CHARACTER SETS

ModalityWorklist will support only the ISO_IR 100 (ISO 8859-1:1987 Latin alphabet N 1. supplementary set) as extended character sets.

6.1.8 Modality Worklist INFORMATION MODEL Definition

6.1.8.1 ModalityWorklist Mapping of DICOM Entities

**TABLE 3.3-1
MAPPING OF DICOM ENTITIES TO MODALITY WORKLIST ENTITIES**

DICOM	Modality Worklist Entity
Scheduled Procedure Step	Exam
Requested Procedure	Exam
Imaging Service Request	Exam
Visit	Exam
Patient	Patient

6.1.8.2 Information Model MODULE TABLE

Table 3.4-1 identifies the defined modules within the entities which comprise the DICOM Modality Worklist Information Model. Modules are identified by Module Name.

See DICOM PS 3.3 and PS 3.4 for a complete definition of the entities, modules, and attributes.

**TABLE 3.4-1
MODALITY WORKLIST INFORMATION MODEL MODULES**

Entity Name	Module Name	Reference
Scheduled Procedure Step	SOP Common	3.5.2.1
	Scheduled Procedure Step	3.5.2.2
Requested Procedure	Requested Procedure	3.5.3.1
Imaging Service Request	Imaging Service Request	3.5.4.1
Visit	Visit Identification	3.5.5.1
	Visit Status	3.5.5.2
	Visit Relationship	3.5.5.3
	Visit Admission	3.5.5.4
Patient	Patient Relationship	3.5.6.1
	Patient Identification	3.5.6.2
	Patient Demographic	3.5.6.3
	Patient Medical	3.5.6.4

6.1.8.3 INFORMATION Model Keys

Please refer to DICOM Standard PS 3.3. (Information Object Definitions) and PS 3.4 (Service Class Specifications) for a description of each of the Entities contained within the Modality Worklist Information Model.

The following Module descriptions contain the attributes which are present in a C-FIND request message sent by the Worklist Server AE to a remote AE. It should be noted that they are the same as those defined in the DICOM Standard, PS 3.4 (Service Class Specifications) and include:

- Name
- Tag group and element numbers
- Expected Matching Key Type: R-required, O-optional
- Expected Return Key Type:
 - 1 - non-zero value required
 - 1C - conditionally of type 1
 - 2 - required to be present, possibly with zero-length value
 - 3 - optional
- Mapped into The Image - whether this data is mapped into subsequently acquired images

- Notes - clarification of this implementation's use/treatment of this attribute

All data elements in the following Module descriptions are requested by the Worklist Server AE. Values of data elements that are not mapped into images, and are not otherwise dealt with (displayed on the user interface, etc.), are not used and are, thus, discarded upon receipt. See Table B-1 for further information.

Data elements for which values can be sent for matching purposes are described as such. Data elements for which values are not sent are sent with zero length and universal matching will apply. This is the default case if no other description to the contrary is provided.

6.1.8.4 Supported Matching

The following are the types of matching that can be request by the implementation:

- Single Value matching
- Universal Matching
- Range of date/time

6.1.8.5 Scheduled Procedure Step Entity

6.1.8.5.1 SOP Common Module

**TABLE 3.5-1
SOP COMMON MODULE ATTRIBUTES**

Attribute Name	Tag	Expected Matching Key Type	Expected Returned Key Type	Mapped into the Image	Note
Specific Character Set	(0008,0005)	O	1C	No	Matching for this item is supported only for the character set ISO_IR 100. This value is always sent and therefore, must be returned.

6.1.8.5.2 Scheduled Procedure Step Module

**TABLE 3.5-2
SCHEDULED PROCEDURE STEP MODULE ATTRIBUTES**

Attribute Name	Tag	Expected Matching Key Type	Expected Returned Key Type	Mapped into the Image	Note
Scheduled Procedure Step Sequence	(0040,0100)	R	1	No	
>Scheduled Station AE Title	(0040,0001)	R	1	No	Matching is supported as follows: either no AE title is supplied (universal matching), or the scanner's Worklist Server AE title is supplied for matching; this is user selectable.

>Scheduled Procedure Step Start Date	(0040,0002)	R	1	No	Matching is supported as one of the following; this is user selectable: <ul style="list-style-type: none"> • all days, • today only, • today and a number of days before today, • today and a number of days after today, • today and a number of days before today and a number of days after today. Number of days before/after is specified by the user. Returned values must be exactly 8 numeric characters in YYYYMMDD format.
>Scheduled Procedure Step Start Time	(0040,0003)	R	1	No	This attribute is sent with zero-length. Returned values must be numeric characters in HHMMSS format.
>Modality	(0008,0060)	R	1	Yes	Matching is supported as follows: either no Modality is supplied (universal matching), or the scanner's Modality is supplied for matching; this is user selectable.
>Scheduled Performing Physician's Name	(0040,0006)	R	2	No	This attribute is sent with zero-length.
>Scheduled Procedure Step Description	(0040,0007)	O	1C	Yes	
>Scheduled Station Name	(0040,0010)	O	2	No	
>Scheduled Procedure Step Location	(0040,0011)	O	2	No	
>Scheduled Action Item Code Sequence	(0040,0008)	O	1C	No	
>>Code Value	(0008,0100)	O	1C	No	
>>Coding Scheme Designator	(0008,0102)	O	1C	No	
>>Code Meaning	(0008,0104)	O	3	No	
>Pre-Medication	(0040,0012)	O	2C	No	
>Scheduled Procedure Step ID	(0040,0009)	O	1	Yes	
>Requested Contrast Agent	(0032,1070)	O	2C	No	Displayed on "More Info..." screen.

6.1.8.6 Requested Procedure Entity

6.1.8.6.1 Requested Procedure Module

**TABLE 3.5-3
REQUESTED PROCEDURE MODULE ATTRIBUTES**

Attribute Name	Tag	Expected Matching Key Type	Expected Returned Key Type	Mapped into the Image	Note
Requested Procedure ID	(0040,1001)	O	1	Yes	User can enter the value for Requested Procedure Id prior to query. If user has entered the value then that value will be sent as part of the query. The value returned in the response shall be mapped to the image.
Requested Procedure Description	(0032,1060)	O	1C	Yes	Truncated to 22 characters.
Requested Procedure Code Sequence	(0032,1064)	O	1C	No	
>Code Value	(0008,0100)	O	1C	No	
>Coding Scheme Designator	(0008,0102)	O	1C	No	
>Code Meaning	(0008,0104)	O	3	No	
Study Instance UID	(0020,000D)	O	1	Yes (Based on User option)	User (Modality) will be able to configure the following. If the user has set the option to "Use MWL Study UID", then study Instance UID will be copied into the final DICOM image header. If this option is not set then a new Study instance UID is generated locally on the scanner.
Referenced Study Sequence	(0008,1110)	O	2	No	
>Referenced SOP Class UID	(0008,1150)	O	1C	No	
>Referenced SOP Instance UID	(0008,1155)	O	1C	No	
Requested Procedure Priority	(0040,1003)	O	2	No	
Patient Transport Arrangements	(0040,1004)	O	2	No	
Requested Procedure Location	(0040,1005)	O	3	No	
Confidentiality Code	(0040,1008)	O	3	No	

6.1.8.7 Imaging Service Request Entity

6.1.8.7.1 Imaging Service Request Module

TABLE 3.5-4
IMAGING SERVICE REQUEST MODULE ATTRIBUTES

Attribute Name	Tag	Expected Matching Key Type	Expected Returned Key Type	Mapped into the Image	Note
----------------	-----	----------------------------	----------------------------	-----------------------	------

Accession Number	(0008,0050)	O	2	Yes	User will be able to enter value for Accession Number prior to query to be sent as part of C-FIND request. Supports maximum of 16 characters.
Requesting Physician	(0032,1032)	O	2	No	
Referring Physician's Name	(0008,0090)	O	2	Yes	Truncated to 32 characters
Requesting Service	(0032,1033)	O	3	No	

6.1.8.8 Visit Entity

6.1.8.8.1 Visit Identification

TABLE 3.5-5
VISIT IDENTIFICATION MODULE ATTRIBUTES

Attribute Name	Tag	Expected Matching Key Type	Expected Returned Key Type	Mapped into the Image	Note
Admission ID	(0038,0010)	O	2	No	
Institution Name	(0008.0080)	O	3	No	

6.1.8.8.2 Visit Status

TABLE 3.5-6
VISIT STATUS MODULE ATTRIBUTES

Attribute Name	Tag	Expected Matching Key Type	Expected Returned Key Type	Mapped into the Image	Note
Current Patient Location	(0038,0300)	O	2	No	Displayed on "More Info..." screen.

6.1.8.8.3 Visit Relationship

**TABLE 3.5-7
VISIT RELATIONSHIP MODULE ATTRIBUTES**

Attribute Name	Tag	Expected Matching Key Type	Expected Returned Key Type	Mapped into the Image	Note
Referenced Patient Sequence	(0008,1120)	O	2	No	
>Referenced SOP Class UID	(0008,1150)	O	2	No	
>Referenced SOP Instance UID	(0008,1155)	O	2	No	

6.1.8.8.4 Visit Admission

No data elements are requested from the Visit Admission Module.

6.1.8.9 Patient Entity

6.1.8.9.1 Patient Relationship

No data elements are requested from the Patient Relationship Module.

6.1.8.9.2 Patient Identification

**TABLE 3.5-8
PATIENT IDENTIFICATION MODULE ATTRIBUTES**

Attribute Name	Tag	Expected Matching Key Type	Expected Returned Key Type	Mapped into the Image	Note
Patient's Name	(0010,0010)	R	1	Yes	This attribute is sent with zero-length. Supports upto 32 characters. See also Note1 . User can also specify the patient name to search for on the Discovery ST UI.
Patient ID	(0010,0020)	R	1	Yes	This attribute is sent with zero-length. Supports upto 16 characters. User can also specify the patient ID to search for on the Discovery ST UI.

Note 1 :

- Modality Worklist server supports 32 characters for patient Name
- Supports DICOM format for patient Name (with “^” as delimiters)
- If patient name in worklist has more than 32 characters then
 - Worklist will be accepted by the server
 - Worklist Browser will display only the first 32 characters
 - “More Info” screen will display the full patient name
 - **Only the FIRST 32 characters is copied into the final DICOM image header**

- Patient Demographic

**TABLE 3.5-9
PATIENT DEMOGRAPHIC MODULE ATTRIBUTES**

Attribute Name	Tag	Expected Matching Key Type	Expected Returned Key Type	Mapped into the Image	Note
Patient's Birth Date	(0010,0030)	O	2	Yes	This value is also used to calculate the Patient's Age.
Patient's Sex	(0010,0040)	O	2	Yes	
Patient's Weight	(0010,1030)	O	2	Yes	Limited to maximum value of 999 kg.
Confidentiality constraint on patient data	(0040,3001)	O	2	No	
Patient's Size	(0010,1020)	O	3	No	
Patient's Address	(0010,1040)	O	3	No	
Patient's Telephone Numbers	(0010,2154)	O	3	No	

6.1.8.9.3 Patient Medical

**TABLE 3.5-10
PATIENT MEDICAL MODULE ATTRIBUTES**

Attribute Name	Tag	Expected Matching Key Type	Expected Returned Key Type	Mapped into the Image	Note
Patient State	(0038,0500)	O	2	No	
Pregnancy Status	(0010,21C0)	O	2	No	Displayed on "More Info..." screen.
Medical Alerts	(0010,2000)	O	2	No	Displayed on "More Info..." screen.
Contrast Allergies	(0010,2110)	O	2	No	Displayed on "More Info..." screen.
Special Needs	(0038,0050)	O	2	No	Displayed on "More Info..." screen.
Additional Patient History	(0010,21B0)	O	3	Yes	Displayed on "More Info..." screen.

6.1.9 Private data dictionary

The ModalityWorklist implementation does not define any Private Attributes within the Modality Worklist Information Model.

6.1.10 C-FIND Request Message

This section provides a detailed description of the C-FIND request message data that is provided to the remote AE during a worklist query operation. The dump in Table D-1 below lists, in exact message order, the fields transferred as part of the C-FIND request message for a typical query.

In this particular dump, no values are specified for the Scheduled Procedure Step Start and End Dates (the attributes are sent with zero length). In DICOM this is interpreted as meaning all dates (i.e. universal matching). The Modality is also not specified in this particular dump, meaning all modalities. Note that the user,

through the use of the Discovery ST user interface, can submit a worklist query that will cause non-zero values to be sent for these attributes.

Worklist query is supported only for CT & MR modalities. PET modality worklists can be queried by using “All Systems” options on UI – but the resulting PET Worklist item will show the modality as ‘MX’.

**TABLE D-1
C-FIND REQUEST MESSAGE DUMP**

```

(0008,0000) UL      108          #      4, 1  IdentifyingGroupLength
(0008,0005) CS      [ISO_IR 100] #     12, 1  SpecificCharacterSet
(0008,0050) SH      (no value available) #      0, 0  AccessionNumber
(0008,0080) LO      (no value available) #      0, 0  InstitutionName
(0008,0090) PN      (no value available) #      0, 0  ReferringPhysicianName
(0008,1110) SQ      (Sequence with explicit Length #=1) #     24, 1  ReferencedStudySequence
(fffe,e000) na      (Item with explicit Length #=2) #     16, 1  Item
(0008,1150) UI      (no value available) #      0, 0  ReferencedSOPClassUID
(0008,1155) UI      (no value available) #      0, 0  ReferencedSOPInstanceUID
(fffe,e00d) na      (ItemDelimitationItem for re-encoding) #      0, 1  ItemDelimitationItem
(fffe,e0dd) na      (SequenceDelimitationItem for re-enc.) #      0, 1  SequenceDelimitationItem
(0008,1120) SQ      (Sequence with explicit Length #=1) #     24, 1  ReferencedPatientSequence
(fffe,e000) na      (Item with explicit Length #=2) #     16, 1  Item
(0008,1150) UI      (no value available) #      0, 0  ReferencedSOPClassUID
(0008,1155) UI      (no value available) #      0, 0  ReferencedSOPInstanceUID
(fffe,e00d) na      (ItemDelimitationItem for re-encoding) #      0, 1  ItemDelimitationItem
(fffe,e0dd) na      (SequenceDelimitationItem for re-enc.) #      0, 1  SequenceDelimitationItem
(0010,0000) UL      96          #      4, 1  PatientGroupLength
(0010,0010) PN      (no value available) #      0, 0  PatientName
(0010,0020) LO      (no value available) #      0, 0  PatientID
(0010,0030) DA      (no value available) #      0, 0  PatientBirthDate
(0010,0040) CS      (no value available) #      0, 0  PatientSex
(0010,1000) LO      (no value available) #      0, 0  Other Patient IDs
(0010,1020) DS      (no value available) #      0, 0  PatientSize
(0010,1030) DS      (no value available) #      0, 0  PatientWeight
(0010,1040) LO      (no value available) #      0, 0  PatientAddress
(0010,2000) LO      (no value available) #      0, 0  MedicalAlerts
(0010,2110) LO      (no value available) #      0, 0  ContrastAllergies
(0010,2154) SH      (no value available) #      0, 0  PatientTelephoneNumber
(0010,2160) SH      (no value available) #      0, 0  Ethinc Group
(0010,21b0) LT      (no value available) #      0, 1  AdditionalPatientHistory
(0010,21c0) US      (no value available) #      0, 0  PregnancyStatus
(0010,4000) LT      (no value available) #      0, 0  Patient Comments
(0020,0000) UL      8          #      4, 1  ImageGroupLength
(0020,000d) UI      (no value available) #      0, 0  StudyInstanceUID
(0032,0000) UL      64          #      4, 1  StudyGroupLength
(0032,1032) PN      (no value available) #      0, 0  RequestingPhysician
(0032,1033) LO      (no value available) #      0, 0  RequestingService
(0032,1060) LO      (no value available) #      0, 0  RequestedProcedureDescription
(0032,1064) SQ      (Sequence with explicit Length #=1) #     32, 1  RequestedProcedureCodeSequence
(fffe,e000) na      (Item with explicit Length #=3) #     24, 1  Item
(0008,0100) SH      (no value available) #      0, 0  CodeValue
(0008,0102) SH      (no value available) #      0, 0  CodingSchemeDesignator
(0008,0104) LO      (no value available) #      0, 0  CodeMeaning
(fffe,e00d) na      (ItemDelimitationItem for re-encoding) #      0, 1  ItemDelimitationItem
(fffe,e0dd) na      (SequenceDelimitationItem for re-enc.) #      0, 1  SequenceDelimitationItem
(0038,0000) UL      32          #      4, 1  VisitGroupLength
(0038,0010) LO      (no value available) #      0, 0  AdmissionID
(0038,0050) LO      (no value available) #      0, 0  SpecialNeeds
(0038,0300) LO      (no value available) #      0, 0  CurrentPatientLocation
(0038,0500) LO      (no value available) #      0, 0  PatientState
(0040,0000) UL      192         #      4, 1  ModalityWorklistGroupLength
(0040,0100) SQ      (Sequence with explicit Length #=1) #    136, 1  ScheduledProcedureStepSequence
(fffe,e000) na      (Item with explicit Length #=12) #   128, 1  Item
(0008,0060) CS      (no value available) #      0, 0  Modality
(0032,1070) LO      (no value available) #      0, 0  RequestedContrastAgent
(0040,0001) AE      (no value available) #      0, 0  ScheduledStationAETitle
(0040,0002) DA      (no value available) #      0, 0  ScheduledProcedureStepStartDate
(0040,0003) TM      (no value available) #      0, 0  ScheduledProcedureStepStartTime
(0040,0006) PN      (no value available) #      0, 0  ScheduledPerformingPhysiciansName
(0040,0007) LO      (no value available) #      0, 0  ScheduledProcedureStepDescription

```

```
(0040,0008) SQ (Seq with explicit Length #=1) # 32, 1 ScheduledActionItemCodeSequence
(fffe,e000) na (Item with explicit Length #=3) # 24, 1 Item
(0008,0100) SH (no value available) # 0, 0 CodeValue
(0008,0102) SH (no value available) # 0, 0 CodingSchemeDesignator
(0008,0104) LO (no value available) # 0, 0 CodeMeaning
(fffe,e00d) na (ItemDelimitationItem for re-encoding) # 0, 1 ItemDelimitationItem
(fffe,e0dd) na (SequenceDelimitationItem for re-enc.) # 0, 1 SequenceDelimitationItem
(0040,0009) SH (no value available) # 0, 0 ScheduledProcedureStepID
(0040,0010) SH (no value available) # 0, 0 ScheduledStationName
(0040,0011) SH (no value available) # 0, 0 ScheduledProcedureStepLocation
(0040,0012) LO (no value available) # 0, 0 PreMedication
(fffe,e00d) na (ItemDelimitationItem for re-encoding) # 0, 1 ItemDelimitationItem
(fffe,e0dd) na (SequenceDelimitationItem for re-enc.) # 0, 1 SequenceDelimitationItem
(0040,1001) SH (no value available) # 0, 0 RequestedProcedureID
(0040,1003) SH (no value available) # 0, 0 RequestedProcedurePriority
(0040,1004) LO (no value available) # 0, 0 PatientTransportArrangements
(0040,1005) LO (no value available) # 0, 0 RequestedProcedureLocation
(0040,1008) LO (no value available) # 0, 0 ConfidentialityCode
(0040,1010) PN (no value available) # 0, 0 Names of Intended Recipients
(0040,1400) LT (no value available) # 0, 0 Requested Procedure Comments
(0040,2400) LT (no value available) # 0, 0 Imaging Service Request Comm.
(0040,3001) LO (no value available) # 0, 0 ConfidentialityConstraintOnPatientData
```

If the query is for a particular date range, the ScheduledProcedureStepStartDate will be filled with a valid date range. If either the start or end date are left blank by the user, they will simply be blank in the query.

Below is an example of a date range for August 30, 1997 through October 12, 1997.

```
(0040,0002) DA [19970830-19971012] # 18, 1 ScheduledProcedureStepStartDate
```

Below is an example of a date range for August 30, 1997 through the end of time.

```
(0040,0002) DA [19970830-] # 18, 1 ScheduledProcedureStepStartDate
```

Below is an example of a date range from the beginning of time through August 30, 1997.

```
(0040,0002) DA [-19970830] # 18, 1 ScheduledProcedureStepStartDate
```

If the query is for records for this modality, the Modality will be filled in as follows:

```
(0008,0060) CS [CT] # 2, 1 Modality
```

If the query is for records for this Scanner, the Modality will be filled in with CT as above and the Scheduled Station AE Title will be filled in with the value configured for this system. For example, this station was configured as CTRoom1.

```
(0040,0001) AE [CTRoom1] # 8, 1 ScheduledStationAETitle
```

User will be able to enter the values for "Accession Number" prior to the query. If value is entered then that value will be sent as part of the query. For example, if "1234" is entered then

```
(0008,0050) SH [1234] # 4, 1 AccessionNumber
```

User will be able to enter the values for “Requested Procedure Id” prior to the query. If value is entered then that value will be sent as part of the query. For example, if “3456” is entered then

(0040,1001) SH [3456] # 4, 1 RequestedProcedureID

6.1.11 Use of Specific DICOM Data

This section details the use of the DICOM data returned by remote AEs during worklist queries. The Discovery ST user interface fields which display the data, along with the data’s mapping into resulting acquired and transferred DICOM images, is presented in following table D-2.

**TABLE D-2
SPECIFIC DATA USAGE**

DICOM Worklist Data Element	Patient Schedule Screen Field	Discovery ST DICOM Image Data Element
Accession Number (0008,0050)	Req Number	Accession Number Supports maximum of 16 characters.
Patient ID (0010,0020)	Patient ID	Patient ID Supports maximum of 16 characters.
Patient Name (0010,0010)	Patient Name	Patient Name Supports maximum of 32 characters.
Patient’s Birth Date (0010,0030)	Patient Age (Patient Birth Date user to calculate age)	Patient Birth Date
Patient’s Sex (0010,0040)	Sex	Patient’s Sex
Patient’s Weight (0010,1030)	Weight in Kg	Patient’s Weight
Referring Physician’s Name (0008,0090)	Referring Physician	Referring Physician’s Name
Requested Procedure Description (0032,1060)	Exam Description	Study Description.
Scheduled Procedure Step Start Date (0040,0002)	Date	Not available.
Scheduled Procedure Step Start Time (0040,0003)	Time	Not available.
Study Instance UID (0020,000d)	Study instance UID (only displayed on the “More Info...” screen)	Study Instance UID , if User has set the preference to “Use MWL Study UID” .
Requested Procedure Id (0040,1001)	Requested Proc ID	Requested Procedure Id.
Pregnancy Status (0010,21C0)	Pregnancy Status (only displayed on the “More Info...” screen)	Not available.
Medical Alerts (0010,2000)	Medical Alerts (only displayed on the “More Info...” screen)	Not available.
Contrast Allergies (0010,2110)	Contrast Allergies (only displayed on the “More Info...” screen)	Not available.

Special Needs (0038,0050)	Special Needs (only displayed on the “More Info...” screen)	Not available.
Requested Contrast Agent (0032,1070)	Requested Contrast Agent (only displayed on the “More Info...” screen)	Not available.
Current Patient Location (0038,0300)	Current Patient Location (only displayed on the “More Info...” screen)	Not available.
Additional Patient History (0010,21B0)	Additional Patient History (only displayed on the “More Info...” screen)	Patient History.

Note that the display of a specific data item on the “More Info...” screen is contingent on the item being enabled for display. Depending on the preferences of each specific site, data can either be displayed or not. A GE field service engineer can assist in setting these site preferences.

6.1.12 Setting User Preferences

6.1.12.1 Setting “Use MWL Study UID” Option

Setting this option to “**Yes**” will copy the **Study Instance UID** from work-list into the final **DICOM Image header**. If this option is set to “**No**” then a new study instance uid will be generated locally.

- Click on “Patient Schedule”
- Click on “Preferences” button
- Set the option “Use Study Instance UID”, to either “**Yes**” or “**No**”

6.1.12.2 Setting Custom Query Option

This option will allow the user to enter values for “Accession Number” and / or “Requested Procedure Id” , which are used for Custom Query.

- Click on “Patient Schedule”
- Click on “Preferences” button
- Set the option “**Show Update Parameters** ”, to “**Yes**”
- To do a query click on “Update” button
- A User Interface will show, which has provision to enter values for
 - Accession Number
 - Requested Procedure Id

7 PERFORMED PROCEDURE STEP CONFORMANCE STATEMENT

7.1.1 INTRODUCTION

This section of the DICOM Conformance Statement specifies the Discovery ST compliance to DICOM conformance requirements for the Performed Procedure Step feature on this GEMS product.

The Connect Pro option for Discovery ST allows a Modality Performed Procedure Step to be communicated to the Hospital/Radiology information system. The PPS feature provides the DICOM Modality Performed Procedure Step service as a service class user (SCU).

This feature works in conjunction with DICOM Modality Worklist feature, if installed. However the conformance of this feature is independent of Modality worklist feature. For information on conformance of the Modality WorkList feature, please refer to the section 6.

7.1.2 IMPLEMENTATION MODEL

The DICOM 'Performed Procedure Step' service is provided by the CT DICOM Server AE (PPS Server). The PPS Server DICOM AE is commanded to perform Performed Procedure Step services either automatically or through the user interface. However, it is to be noted that the CT and PET scans cannot be separated into different Procedure Steps. One PET/CT exam on Discovery ST results in a single Performed Procedure Step.

7.1.2.1 APPLICATION DATA FLOW DIAGRAM

ILLUSTRATION 7-0

MODALITY PERFORMED PROCEDURE STEP DATA FLOW DIAGRAM

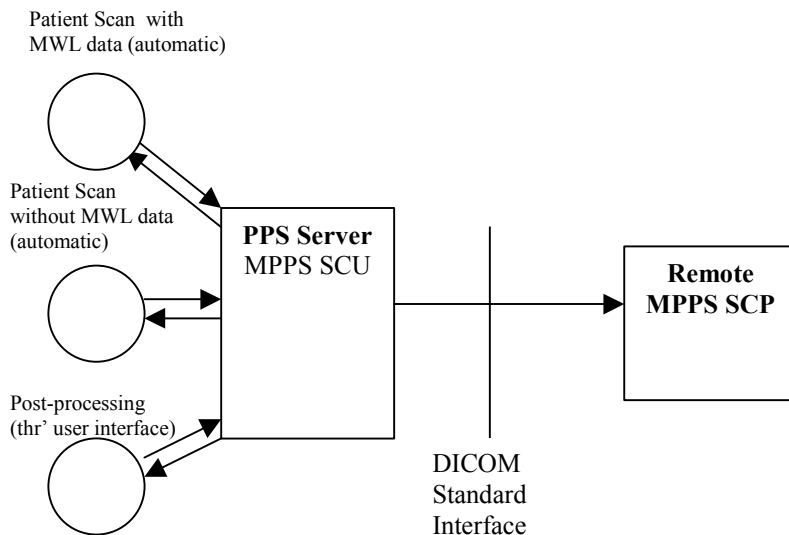

7.1.2.2

Functional Definition of AEs

The CT PPS Server AE is implemented as an application process on the scanner host computer. It runs as a daemon serving requests from other applications to send the PPS information to the remote AE and return the results to the requesting application.

The CT PPS Server AE initiates the following functions.

- *Start PPS*: Initiates a DICOM association in order to create a DICOM Modality Performed Procedure Step SOP instance in the remote AE. If the remote AE accepts a presentation context applicable to Modality performed Procedure Step, the PPS Server AE will issue a request to create the SOP instance in the remote AE via the N-CREATE service.
- *Complete PPS*: Initiates a DICOM association in order to update a DICOM Modality Performed Step instance that is already created with the remote AE. If the remote AE accepts a presentation context applicable to Modality performed Procedure Step, the PPS Server AE will issue a request to update the SOP instance in the remote AE via the N-SET service. The PPS Status is set to 'COMPLETED'.
- *Discontinue PPS*: Initiates a DICOM association in order to update a DICOM Modality Performed Step instance that is already created with the remote AE. If the remote AE accepts a presentation context applicable to Modality performed Procedure Step, the PPS Server AE will issue a request to update the SOP instance in the remote AE via the N-SET service. The PPS Status is set to 'DISCONTINUED'.

7.1.2.3

Sequencing of Real-World Activities

7.1.2.3.1

PPS from acquisition system with MWL data

The system has a CT Modality Worklist Server AE installed. Worklist information is obtained from HIS/RIS system through the use of Basic Worklist Management Service. Use of the information retrieved in the creation of Image SOP instance is described in the Modality Worklist Conformance section. Use of the information retrieved in MPPS SOP instances is described later in this document.

- The system initiates a 'Start PPS' before starting a scan, i.e. when the image acquisition is started. The system retrieves necessary information related to the Scheduled Procedure Step from Modality Worklist Server. PPS Server AE initiates a MPPS (Modality Performed Procedure Step) N-CREATE request to the remote AE (MPPS SCP), in-order to create a MPPS SOP instance at the remote AE.
- The MPPS SCP returns response indicating the success/failure of the request execution. The PPS state information is updated in the system based on the response data, and is presented to the user. **The DICOM association is closed.**
- System includes the necessary information related to Scheduled Procedure Steps and the Performed procedure Step in the image instances created.
- At the end of image acquisition, system initiates a 'Complete PPS' or 'Discontinue PPS' based on the choice selected by the user using the user interface provided. The user is also given a choice 'Defer PPS' which is described below. PPS Server AE initiates a MPPS N-SET request to the remote AE, in-order to update the MPPS SOP instance,

that is already created. **The N-SET is sent over a new DICOM association**

- The remote AE returns response indicating the success/failure of the request execution. The PPS state information is updated in the system based on the response data, and is presented to the user.
- At the end of image acquisition, if the user has chosen 'Defer PPS', the user is provided with an interface to 'Complete PPS' or 'Discontinue PPS' at any later time. The user might wish to alter the image set generated through acquisition, before invoking these operations. Note that the user explicitly uses the user interface provided to invoke this operation, as in the case of PPS generated for post-processing, which is described in the following section. **PPS messages N-CREATE (if applicable) and N-SET will be sent over the same DICOM association**
- The remote AE returns response indicating the success/failure of the request execution. The PPS state information is updated in the system based on the response data, and is presented to the user.

7.1.2.3.2

PPS from acquisition system without MWL data

The system either does not have a CT Modality Worklist Server AE installed or a Modality Worklist Server AE installed but no Worklist information is obtained from HIS/RIS system for the current procedure that is being performed. The information required for performing the procedure is supplied through the user interface of the system. The use of this information in MPPS SOP instances is described later in this document.

- The system initiates a 'Start PPS' before starting a scan, i.e. when the image acquisition is started. PPS Server AE initiates a MPPS (Modality Performed Procedure Step) N-CREATE request to the remote AE (MPPS SCP), in-order to create a MPPS SOP instance at the remote AE.
- The MPPS SCP returns response indicating the success/failure of the request execution. The PPS state information is updated in the system based on the response data, and is presented to the user.
- System includes the necessary information related to Scheduled Procedure Steps and the Performed procedure Step in the image instances created.
- At the end of image acquisition, system initiates a 'Complete PPS' or 'Discontinue PPS' based on the choice selected by the user using the user interface provided. The user is also given a choice 'Defer PPS' which is described below. PPS Server AE initiates a MPPS N-SET request to the remote AE, in-order to update the MPPS SOP instance, that is already created.
- The remote AE returns response indicating the success/failure of the request execution. The PPS state information is updated in the system based on the response data, and is presented to the user.
- At the end of image acquisition, if the user has chosen 'Defer PPS', the user is provided with an interface to 'Complete PPS' or 'Discontinue PPS' at any later time. The user might wish to alter the image set generated through acquisition, before invoking these operations. Note that the user explicitly uses the user interface provided to invoke this operation, as in the case of PPS generated for post-processing, which is described in the following section.

- The remote AE returns response indicating the success/failure of the request execution. The PPS state information is updated in the system based on the response data, and is presented to the user.

7.1.2.3.3 PPS from post-processing system

- The user initiates post-processing on the images generated through acquisition. Note that only certain applications supports this option.
- The system creates a Modality performed Procedure Step instance locally in the system. If the source image instances has the Scheduled Procedure Step information, it is copied into the image instances created. Also the system includes the necessary information related to the Modality Performed Procedure Step into the image instance.
- At the end of (one or more) post-processing, the user initiates 'Complete PPS' or 'Discontinue PPS' through the user interface provided. PPS Server AE initiates a MPPS (Modality Performed Procedure Step) N-CREATE request to the remote AE (MPPS SCP), in-order to create a MPPS SOP instance at the remote AE (which is actually a replica of the locally created MPPS SOP instance).
- The remote AE returns response indicating the success/failure of the request execution. If the response indicates success, PPS Server AE initiates a MPPS N-SET request to the remote AE, in-order to update the MPPS SOP instance, that is already created, with the additional information.
- The remote AE returns response indicating the success/failure of the request execution. The PPS state information is updated in the system based on the response data, and is presented to the user.

7.1.3 AE SPECIFICATION

7.1.3.1 PPS Server AE Specification

This Application Entity provides Standard Conformance to the following DICOM SOP Classes as an SCU:

SOP Class Name	SOP Class UID
Modality Performed Procedure Step	1.2.840.10008.3.1.2.3.3

7.1.3.1.1 Association Establishment Policies

7.1.3.1.1.1 General

The DICOM Application Context Name (ACN), which is always proposed, is:

Application Context Name	1.2.840.10008.3.1.1.1
--------------------------	-----------------------

The Maximum Length PDU negotiation is included in all association establishment requests. The maximum length PDU from an association initiated by the PPS Server AE is:

Maximum Length PDU	128 Kbytes
--------------------	------------

The SOP Class Extended negotiation is not supported.

The maximum number of presentation negotiation items that will be proposed is 1.

7.1.3.1.1.2 Number of Associations

The PPS Server will initiate only one DICOM association at any time to perform a PPS operation to the remote AE.

7.1.3.1.1.3 Asynchronous Nature

Asynchronous mode is not supported. All operations are performed synchronously.

7.1.3.1.1.4 Implementation Identifying information

The implementation UID for this DICOMv3.0 Implementation is:

PPS Feature for Discovery ST Implementation UID	1.2.840.113619.6.55
--	---------------------

7.1.3.1.2 Association Initiation Policy

The PPS Server AE initiates a new association for every PPS operation initiated.

7.1.3.1.2.1 Real-World Activity: Performed Procedure Step creation and update

Associated Real-World Activity

The real-world activities are mentioned in section 7.2.3 *Sequencing of Real-World Activities*. Each of the real world activity results in either creating a new Performed procedure Step SOP instance at the remote SCP or updating an already created Performed Procedure Step SOP instance as per the DICOM standard.

Proposed Presentation Context Table

The following table shows the proposed presentation contexts for the PPS Server AE after any of the real-world activity listed in section 7.2.3 *Sequencing of Real-World Activities*, is initiated.

Presentation Context Table - Proposed					
Abstract Syntax		Transfer Syntax		Role	Extended Negotiation
Name	UID	Name List	UID List		
Modality Performed Procedure Step	1.2.840.10008.3.1.2.3.3	Implicit VR Little Endian	1.2.840.10008.1.2	SCU	None

SOP Specific DICOM Conformance Statement for MPPS SOP class

If the remote AE does not support the proposed Presentation context, an appropriate error message logged. Only one association is opened at a time.

All the operations used by this SOP class support an association timer, which is configurable. The timer is started when a request (association request, N-CREATE request or N-SET request) is send and stopped when the respective response is received. The default time-out value is 300 seconds.

All the operations used by this SOP class support a "Session Timer". This timer is started when the association is established and stopped when association is ended. The default time-out value is 3000 seconds.

If any of the above timers expires the association is aborted and the operation in-progress is considered FAILED.

In any case an operation (N-CREATE or N-SET) fails, system updates the state to enable operator to manually invoke the operation at any later time.

7.1.3.1.3 Association Acceptance Policy

The PPS Server AE does not respond to attempts by remote AE to open an association.

7.1.4 COMMUNICATION PROFILES

7.1.4.1 Supported Communication Stacks (PS 3.8)

DICOM Upper Layer (PS 3.8) is supported using TCP/IP.

7.1.4.2 OSI Stack

The OSI Communication stack is not supported by this implementation.

7.1.4.3 TCP/IP Stack

The TCP/IP stack is inherited from the IRIX operating system.

7.1.4.3.1 API

Not Applicable to this product.

7.1.4.3.2 Physical Media Support

Ethernet 802.3 provides the physical network layer for this product.

7.1.4.4 Point-to-Point Stack

The Point-to-Point Stack is not supported by this implementation.

7.1.5 EXTENSIONS/SPECIALIZATION/PRIVATIZATION

7.1.5.1 Standard Extended/Specialized/Private SOPs

PPS for Discovery ST does not implement any private SOP classes.

7.1.5.2 Private Transfer Syntaxes

PPS for Discovery ST does not implement any private Transfer Syntaxes.

7.1.6 CONFIGURATION

The PPS feature is configured by GEMS Field Service Engineers. The DICOM configuration items below are configurable or re-configurable by the Field Service Engineer and are not accessible by users through the Discovery ST's user interface.

7.1.6.1 AE Title/Presentation address Mapping

PPS allows for the configuration of the following parameters which pertain to the remote AE.

- Remote MPPS AE IP Address - IP Address used to contact the remote MPPS AE
- Remote AE (HIS/RIS) IP Port - IP Port used to contact the remote MPPS AE
- Remote MPPS AE Title - Application Entity Title used to contact the remote MPPS AE

These parameters define where the MPPS requests will be directed. Configuration of these parameters is performed by GEMS Field Service engineers, using the installation facilities.

7.1.6.2 Configurable Parameters

The following are configurable for the PPS Server AE:

- Local (PPS Server AE) AE Title (The default is host name of the scanner appended with string “_PPS”)
- Local IP Address
- Local IP net-mask
- Local IP gateway

The following parameters are configurable, but need change only in case of a system software upgrade:

- Implementation UID
- PDU size
- Association time-out period
- Session time-out period

7.1.7 SUPPORT OF EXTENDED CHARACTER SETS

PPS feature for Discovery ST does not support any extended character set.

7.1.8 N-CREATE & NSET REQUEST MESSAGE

PPS Feature for Discovery ST supports all named attributes listed in Table F.7.2.1 in PS3.4 of DICOM standard. That is, attributes that are not explicitly referenced by name in the table are not supported. (Example is last row in the table reads “All other attributes from Radiation Dose Module and Billing and Material Code Module”. The attributes referenced here are not supported).

For the MPPS associated with an acquisition, the following attributes are copied from the Modality Worklist SCU into the MPPS request Message, if procedure performed corresponds to the SPS information retrieved through the Modality Worklist.

Discovery ST supports the selection of **single** or **multiple** SPS for a scan. The following are applicable.

- Single SPS selection results in single PPS message
- Multiple SPS selection results in single PPS message
- Multiple SPS selection is allowed **only if they all correspond to same patient id**
- A maximum of 10 SPS's can be selected
- Referenced Study Sequence - a maximum of five Item's is supported. *This attribute will be present only if SPS information is available from Modality Worklist SCU.*
- At the end of acquisition the user might choose to 'Defer PPS' and later choose to 'Complete PPS' or 'Discontinue PPS' from the user interface provided in the system. In this case, the date and time when user chooses to 'Complete PPS' or 'Discontinue PPS' is taken as the Performed Procedure Step End Date and Performed Procedure Step End Time respectively (Not the actual end date and end time of acquisition)
- Mapping of SPS data to **MPPS SOP instance** is explained in section 7.10
- Mapping of specific SPS data to **CT DICOM IMAGE HEADER** , for PPS is explained in section 7.11

For the MPPS associated with a post-processing the following restrictions apply on the attributes listed below.

- Referenced Study Sequence – The sequence is not sent in the MPPS message
- Scheduled Step Attribute Sequence – a maximum of ONE item is supported. The attribute will be send only if SPS information is available in the image instance.
- Referenced Patient Sequence – This sequence is not added
- Scheduled action Item Code Sequence – The sequence is not send in the MPPS message
- Performed Procedure Step Start date & Performed Procedure Step start time – The exam date and exam time that is the Start date and Start Time of the associated Study Component (Exam) is used, not the actual time when post-processing started.
- Performed Procedure Step end date & Performed Procedure Step end time - The date and time when user chooses to 'Complete PPS' or 'Discontinue PPS' is taken as the Performed Procedure Step End Date and Performed Procedure Step End Time respectively (Not the actual end date and end time of post-processing).
- Procedure Code Sequence – This sequence is sent with ZERO items in the MPPS message
- Performed Action Item Code Sequence – This sequence is sent with ZERO items in the MPPS message.
- Referenced Standalone SOP Instance Sequence – The sequence is sent with ZERO items in the MPPS message.

7.1.9 ERROR HANDLING AND RECOVERY

PPS Server AE does not define any extended error codes. The standard error codes are handled. On a response with status 'success' for the N-CREATE or N-SET request, the system updates the state and indicates the same on the user interface. On a response with status other than 'success' the operation is deemed 'Failed' and the system updates the state and indicates the same on the user interface. If the request has failed or response is not received before the association timeout, the operation is deemed 'Failed' and the system updates the state and indicates the same on the user interface.

If the operation is 'Failed', detailed message is logged into system log-file and system provides an alternative mechanism to retry the failed operation through the user interface to ensure that transient failures do not affect the feature performance.

7.1.10 USE OF SPECIFIC DICOM DATA

The following table gives specific usage of some of attributes in the MPPS SOP instance created, with reference to each of the real-world scenarios mentioned in 7.2.3 of this document.

Attribute Name	Tag	Usage in MPPS Instance		
		Acquisition with MWL data	Acquisition without MWL data	Post-Processing
Specific Character Set	(0008,0005)	Not used, but copied into image header	Not used	Not used, but copied into image header
Scheduled Step Attribute Sequence	(0040,0270)	Only one item		Only one item
>Study Instance UID	(0020,000D)	Copied from SPS, if option to copy is selected or else created at the scanner	Created at the scanner	Copied from source image
>Referenced Study Sequence	(0008,1110)	Copied from SPS, if selected	Not sent as part of image header	Not sent as part of image header
>Accession Number	(0008,0050)	Copied from SPS, if selected	User input on the scanner	Copied from source image
>Placer Order Number/Imaging Service Request	(0040,2016)	Not sent as part of image header	Not sent as part of image header	Not sent as part of image header
>Filler Order Number/Imaging Service Request	(0040,2017)	Not sent as part of image header	Not sent as part of image header	Not sent as part of image header

Attribute Name	Tag	Usage in MPPS Instance		
		Acquisition with MWL data	Acquisition without MWL data	Post-Processing
>Requested Procedure ID	(0040,1001)	Copied from SPS, if selected	User input on the scanner	Copied from source image
>Requested Procedure Description	(0032,1060)	Copied from SPS, if selected	Not used	Not sent as part of image header
>Placer Order Number/Procedure	(0040,1006)	Not sent as part of image header	Not used	Not sent as part of image header
>Filler Order Number/Procedure	(0040,1007)	Not sent as part of image header	Not used	Not sent as part of image header
>Scheduled Procedure ID	(0040,0009)	Copied from SPS, if selected	Not used	Copied from source image
>Scheduled Procedure Step Description	(0040,0007)	Copied from SPS, if selected	Not used	Copied from source image
>Scheduled Action Item Code Sequence	(0040,0008)	Copied from SPS, if selected	Not used	Not sent as part of image header
Patient's Name	(0010,0010)	Copied from SPS, if selected	User input on the scanner	Copied from source image
Patient ID	(0010,0020)	Copied from SPS, if selected	User input on the scanner	Copied from source image
Patient's Birth Date	(0010,0032)	Copied from SPS, if selected	User input on the scanner	Copied from source image
Patient's Sex	(0010,0040)	Copied from SPS, if selected	User input on the scanner	Copied from source image
Referenced Patient Sequence	(0008,1120)	Copied from SPS, if selected	Not used	No item
Performed Procedure Step ID	(0040,0253)	Created at the scanner. Will have the following "PPS_ID_<exam number"	Created at the scanner. Will have the following "PPS_ID_<exam number"	New generated, may not be unique
Performed Station AE Title	(0040,0241)	Local system host-name	Local system host-name	Local system host-name
Performed Station Name	(0040,0242)	Local system suite id	Local system suite id	Local system host-name
Performed Location	(0040,0243)	Local system suite id	Local system suite id	Not used

Attribute Name	Tag	Usage in MPPS Instance		
		Acquisition with MWL data	Acquisition without MWL data	Post-Processing
Performed Procedure Step Start Date	(0040,0244)	Same as exam start date	Same as exam date	Same as exam date
Performed Procedure Step Start Time	(0040,0245)	Same as exam start time	Same as exam time	Same as exam time
Performed Procedure Step Description	(0040,0254)	Copied from SPS, if selected	Not sent as part of image header	Not sent as part of image header
Performed Procedure Step status	(0040,0252)	See Note 1.	See Note 1.	See Note 1.
Performed Procedure Type Description	(0040,0255)	Not sent as part of image header	Not sent as part of image header	Not sent as part of image header
Procedure Code Sequence	(0008,1032)	Not sent as part of image header	Not sent as part of image header	Not sent as part of image header
Performed Procedure Step End Date	(0040,0250)	Date when all images got installed	Date when all images got installed	The date "Complete PPS" or "Discontinue PPS" is invoked, not the actual end of post-processing
Performed Procedure Step End Time	(0040,0251)	Time when all images got installed	Time when all images got installed	The time "Complete PPS" or "Discontinue PPS" is invoked, not the actual end of post-processing
Modality	(0008,0060)	Value "CT" is stored in image header	Value "CT" is stored in image header	Value "CT" is stored in image header
Study ID	(0020,0010)	Same as exam number	Same as exam number	Copied from source image
Performed Action Item Code Sequence	(0040,0260)	Copied from SPS, if selected	Not used	Not used
Performed Series Sequence	(0040,0340)	One item for each series created	One item for each series created	One item for each series created with post-processing
>Performing Physician's Name	(0008,1050)	Copied from SPS, if selected	User input on the scanner	Not sent as part of image header
>Protocol Name	(0018,1030)	The name of the protocol selected on the scanner	The name of the protocol selected on the scanner	Copied from source image
>Operator's Name	(0008,1070)	Copied from SPS, if selected	User input on the scanner	Not sent as part of image header

Attribute Name	Tag	Usage in MPPS Instance		
		Acquisition with MWL data	Acquisition without MWL data	Post-Processing
>Retrieve AE Title	(0008,0054)	Local system host-name	Local system host-name	host-name of the system
>Referenced Image Sequence	(0008,1140)	One item for each image created within the series	One item for each image created within the series	One item for each image generated by post-processing
>Referenced Standalone SOP Instance Sequence	(0040,0220)	Not sent as part of image header	Not sent as part of image header	Not sent as part of image header
>All other attributes from Performed Series Sequence (which Table F.7.2.1 of DICOM standard PS3.4 does not explicitly list)		Not sent as part of image header	Not sent as part of image header	Not sent as part of image header
All other attributes from Radiation Dose Module and Billing and Material Code Module (which Table F.7.2.1 of DICOM standard PS3.4 does not explicitly list)		Not sent as part of image header	Not sent as part of image header	Not sent as part of image header

Note 1:

- When PPS start (N-CREATE) message is sent, this element will have the value “INPROGRESS”
- When PPS end (N-SET) message is sent, this element will have either “COMPLETE” or “DISCONTINUE” based on user selection

7.1.11 USE OF SPECIFIC DICOM DATA

Attribute Name	Tag	Usage in CT DICOM Image Header
Patient Level		
Patient Name	(0010,0010)	Copied from SPS, if selected
Patient ID	(0010,0020)	Copied from SPS, if selected
Patient Birthdate	(0010,0020)	Copied from SPS, if selected
Patient Sex	(0010,0040)	Copied from SPS, if selected
Referenced Patient Sequence	(0008,1150)	Copied from SPS, if selected
>Ref. SOP class uid	(0008,1150)	
>Ref. SOP Instance uid	(0008,1155)	
Study Level		
Study Instance UID	(0020,000D)	Copied from SPS, if selected
Study ID	(0020,0010)	Copied from SPS, if selected
Referring Physicians	(0008,0090)	Copied from SPS, if selected

name		
Accession Number	(0008m0050)	If multiple SPS's are selected, then accession number from the first selection (determined by the user) is used
Referenced Study Sequence	(0008,1110)	Copied from SPS, if selected
>Ref. SOP class uid	(0008,1150)	
>Ref. SOP Instance uid	(0008,1155)	
Series Level		
Modality	(0008,1060)	Value "CT" is copied
Protocol Name	(0018,1030)	Name of the selected protocol is copied
Operator Name	(0008,0090)	Copied from SPS, if selected
Referenced Study Component Sequence	(0008,1111)	Will be present only if SPS , obtained form HIS/RIS is selected for scanning
>Ref. SOP class uid	(0008,1150)	Value of MPPS SOP class UID
>Ref. SOP Instance uid	(0008,1155)	Scanner generated unique UID
Requested Attribute Sequence	(0040,0275)	Will be present only if SPS , obtained form HIS/RIS is selected for scanning. If multiple SPS's are selected then this will contain multiple items one for each SPS. For all other cases this element will not be present
>Requested Procedure Id	(0040,1001)	Copied from SPS, if selected
>Scheduled Procedure Step Id	(0040,0009)	Copied from SPS, if selected
> Scheduled Procedure Step description	(0040,0007)	Copied from SPS, if selected
>Scheduled Action Item Code Sequence	(0040,0008)	Copied from SPS, if selected
Performed Procedure Step Id	(0040,0253)	Created at the scanner. The string " PPS_ID_<examnumber> " is used.
Performed Procedure Step start date	(0040,0244)	Same as exam start date
Performed Procedure Step start time	(0040,0245)	Same as exam start time
Performed Procedure Step description	(0040,0254)	Exam description is used

A CT/MR IOD Definitions

A.1 CT Specific IOD Definition

A.1.1 CT Image IOD Modules

Entity Name	Module Name	Reference	Usage
Patient	Patient	A.4.1	M
Study	General Study	A.4.2	M
	Patient Study	A.4.3	U
Series	General Series	A.4.4	M
Frame of Reference	Frame of Reference	A.4.12	M
Equipment	General Equipment	A.4.5	M
Image	General Image	A.4.6	M
	Image Plane	A.4.7	M
	Image Pixel	Only the type 1 elements are sent.	M
	Contrast/Bolus	A.4.8	C
	CT Image	A.1.2	M
	VOI LUT	A.4.11	U
	SOP Common	A.4.9	M

A.1.2 CT Image Module

Attribute Name	Tag	Type	Notes
KV	(0018,0060)	2	Value always sent.
Acquisition Number	(0020,0012)	2	Value always sent.
Scan Options	(0018,0022)	3	Value always sent.
Data Collection Diameter	(0018,0090)	3	Value always sent.
Reconstruction Diameter	(0018,1100)	3	Value sent for all images except scouts.
Distance Source to Detector	(0018,1110)	3	Value always sent.
Distance Source to Patient	(0018,1111)	3	Value always sent.
Gantry / Detector Tilt	(0018,1120)	3	Value always sent.
Table Height	(0018,1130)	3	Value always sent.
Rotation Direction	(0018,1140)	3	Not sent for scout or axial.
Exposure Time	(0018,1150)	3	Value always sent.
X-Ray Tube Current	(0018,1151)	3	Value always sent.
Exposure	(0018,1152)	3	Value always sent.
Filter Type	(0018,1160)	3	Sent. Defined terms: <u>BODY FILTER</u> <u>BOWTIE FLAT FILT</u> <u>FLAT FILTER</u> <u>LARGE BOWTIE FIL</u>

Focal Spot	(0018,1190)	3	Sent. Fixed value of 0.7 or 1.2.
Convolution Kernel	(0018,1210)	3	Not sent for scouts. Defined terms: <u>SMOOTH</u> <u>SOFT</u> <u>STANDARD</u> <u>DETAIL</u> <u>BONE</u> <u>EDGE</u> <u>SHARP</u> <u>LUNG</u>

CAUTION

It is possible for the operator of CT LightSpeed QX/i system to change the table height while scanning a series of images. Therefore, implementations must use the Frame of Reference UID (0020,0052) in conjunction with the Table Height (0018,1130) to determine if two images are spatially related.

A.1.2.1 Implementation Specific details

For all CT Images created by Discovery ST patient birth date element (0010,0030) is sent, if the operator has entered the details. If the operator has not entered the details it will be sent as a “Zero length element”

The length of Accession number element (0008,0050) is a maximum of 16 characters Window Center (0028,1050) and Window Width (0028,1051) are sent for all CT Images created by Discovery ST

Based on whether contrast was used or not the following applies for CT Images created by Discovery ST

Mode	(0018,0010)	(0018,1040)
No Contrast	Not sent	Not sent
Oral Contrast	Oral Contrast Agent name	The string “Oral”
IV Contrast	IV Contrast agent name	The String “IV”
Oral and IV contrast	Oral contrast agent “ & “ IV Contrast agent	The string “Oral & IV”

Supported field length for DICOM fields

DICOM Tag	Field Name	Field Length
(0008, 0050)	Accession Number	16 characters
(0010, 0010)	Patient Name	32 characters

(0010, 0020)	Patient Id	16 characters
----------------	------------	---------------

A.2 MR Specific IOD Definition

A.2.1 MR Image IOD Modules

Entity Name	Module Name	Reference	Usage
Patient	Patient	A.4.1	M
Study	General Study	A.4.2	M
	Patient Study	A.4.3	U
Series	General Series	A.4.4	M
Frame of Reference	Frame of Reference	A.4.12	M
Equipment	General Equipment	A.4.5	M
Image	General Image	A.4.6	M
	Image Plane	A.4.7	M
	Image Pixel	Only the type 1 elements are sent.	M
	Contrast/Bolus	A.4.8	C
	MR Image	A.2.2	M
	SOP Common	A.4.9	M

A.2.2 MR Image Module

Attribute Name	Tag	Type	Notes
Scan Options	(0018,0021)	2	Always sent.
MR Acquisition Type	(0018,0023)	2	2D or 3D depending on acquisition type.
Repetition Time	(0018,0080)	2C	Sent if Scanning Sequence is EP and Sequence Variant is <u>not</u> SK .
Echo Time	(0018,0081)	2	Sent.
Inversion Time	(0018,0082)	2C	Sent.
Echo Train Length	(0018,0091)	2	Sent.
Trigger Time	(0018,1060)	2C	Sent.
Angio Flag	(0018,0025)	3	
Number Of Averages	(0018,0083)	3	
Imaging Frequency	(0018,0084)	3	
Imaged Nucleus	(0018,0085)	3	Zero-length element is sent.
Echo Number	(0018,0086)	3	
Magnetic Field Strength	(0018,0087)	3	Image strength, if 0, NOT sent.
Spacing Between Slices	(0018,0088)	3	
Percent Sampling	(0018,0093)	3	
Percent Phase Field of View	(0018,0094)	3	
Pixel Bandwidth	(0018,0095)	3	

Nominal Interval	(0018,1062)	3	
Heart Rate	(0018,1088)	3	If 0, NOT sent.
Cardiac Number of Images	(0018,1090)	3	If 0, NOT sent.
Trigger Window	(0018,1094)	3	If 0, NOT sent.
Reconstruction Diameter	(0018,1100)	3	
Receiving Coil	(0018,1250)	3	
Transmitting Coil	(0018,1251)	3	
Acquisition Matrix	(0018,1310)	3	
Phase Encoding Direction	(0018,1312)	3	
Flip Angle	(0018,1314)	3	
Variable Flip Angle Flag	(0018,1315)	3	
SAR	(0018,1316)	3	
Temporal Resolution	(0020,0110)	3	

A.3 SC Specific IOD Definition

A.3.1 SC Image IOD Modules

Entity Name	Module Name	Reference	Usage
Patient	Patient	A.4.1	M
Study	General Study	A.4.2	M
	Patient Study	A.4.3	U
Series	General Series	A.4.4	M
	Equipment	General Equipment	A.4.5
	SC Equipment	A.4.13	M
Image	General Image	A.4.6	M
	Image Pixel	Only the type 1 elements are sent.	M
	SC Image	Not sent (consists entirely of type 3 element).	M
	Modality LUT	Only the type 1C elements are sent.	U
	VOI LUT	A.4.11	U
	SOP Common	A.4.9	M

A.4 CT/MR/SC IOD Common Module Definitions

A.4.1 Patient Module

Attribute Name	Tag	Type	Notes
Patient's Name	(0010,0010)	2	As entered at user interface or from worklist. Supports 5 different components delimited by "^".

			<i>Supports a maximum length of 32 characters including the delimiter .</i>
Patient ID	(0010,0020)	2	As entered at user interface or from worklist.
Patient's Birth Date	(0010,0030)	2	Always sent zero length.
Patient's Sex	(0010,0040)	2	Always sent.

A.4.2 General Study Module

Attribute Name	Tag	Type	Notes
Study Instance UID	(0020,000D)	1	Generated uniquely for each exam. Value from worklist, if present, is not filled in here.
Study Date	(0008,0020)	2	Generated for each exam and always sent.
Study Time	(0008,0030)	2	Generated for each exam and always sent.
Accession Number	(0008,0050)	2	Value from user interface or worklist sent.
Referring Physician's Name	(0008,0090)	2	Value from user interface sent.
Study ID	(0020,0010)	2	Value from user interface or worklist sent.
Study Description	(0008,1030)	3	Value from user interface sent.
Name of Physician(s) Reading Study	(0008,1060)	3	Sent if entered at the user interface.

A.4.3 Patient Study Module

Attribute Name	Tag	Type	Notes
Patient's Age	(0010,1010)	3	Calculated from Date of Birth entered at user interface.
Patient's Weight	(0010,1030)	3	Value from user interface.
Additional Patient's History	(0010,21b0)	3	Value from user interface.

A.4.4 General Series Module

Attribute Name	Tag	Type	Notes
Series Number	(0020,0011)	2	Generated sequentially, always sent.
Laterality	(0020,0060)	2C	Always sent zero-length.
Series Date	(0008,0021)	3	Generated for each series and always sent.
Series Time	(0008,0031)	3	Generated for each series and always sent.
Performing Physician's Name	(0008,1050)	3	
Protocol Name	(0008,1030)	3	Sent if entered at user interface.
Series Description	(0008,103E)	3	Value from user interface is sent.
Operators Name	(0008,1070)	3	Value from user interface is sent.

Patient Position	(0018,5100)	2C	Sent. As selected by operator when patient is positioned. Defined terms are: HFP = Head-First Prone HFS = Head-First Supine HFDR = Head-First Decubitus Right HFDL = Head-First Decubitus Left FFDR = Feet-First Decubitus Right FFDL = Feet-First Decubitus Left FFP = Feet-First Prone FFS = Feet-First Supine
------------------	-------------	----	--

A.4.5 General Equipment Module

Attribute Name	Tag	Type	Notes
Manufacturer	(0008,0070)	2	Always sent as "GE MEDICAL SYSTEMS"
Institution Name	(0008,0080)	3	Sent. Value is configurable.
Station Name	(0008,1010)	3	Sent. Value is configurable.
Manufacturers Model Name	(0008,1090)	3	
Device Serial Number	(0018,1000)	3	Sent if present in image.
Software Versions	(0018,1020)	3	Always sent as "05" for this version - does not distinguish individual software releases.
Spatial Resolution	(0018,1050)	3	Sent only for MR images.
Pixel Padding Value	(0028,0120)	3	Sent.

A.4.6 General Image Module

Attribute Name	Tag	Type	Notes
Image Number	(0020,0013)	2	Generated based on Scan.scan_mode image_location image_time image_bin_time, always sent.
Patient Orientation	(0020,0020)	2C	Always sent zero length.
Image Date	(0008,0023)	2C	Generated for each image, always sent.
Image Time	(0008,0033)	2C	Generated for each image, always sent.
Image Type	(0008,0008)	3	Always sent.
Acquisition Number	(0020,0012)	3	Generated for each acquisition, always sent.
Acquisition Date	(0008,0022)	3	Generated for each acquisition, always sent.
Acquisition Time	(0008,0032)	3	Generated for each acquisition, always sent.

A.4.7 Image Plane Module

Attribute Name	Tag	Type	Notes
Slice Thickness	(0018,0050)	2	Value always sent.
Image Slice Location	(0020,1041)	3	Value always sent.

A.4.8 Contrast Bolus Module

Attribute Name	Tag	Type	Notes
Contrast/Bolus Agent	(0018,0010)	2	Sent if contrast exam, as entered in user interface.
Contrast/Bolus Route	(0018,1040)	3	Sent if contrast exam, as entered in user interface.

A.4.9 SOP Common Module

Attribute Name	Tag	Type	Notes
Specific Character Set	(0008,0005)	1C	ISO_IR 100

A.4.10 Overlay Plane Module

Attribute Name	Tag	Type	Notes
Overlay Data	(60xx,3000)	1C	Only for SC & Standalone Overlay IOD Definitions

A.4.11 VOI LUT Module

Attribute Name	Tag	Type	Notes
Window Center	(0028,1050)	3	Window Center for display. Always sent.
Window Width	(0028,1051)	1C	Window Width for display. Always sent.

A.4.12 Frame of Reference Module

Attribute Name	Tag	Type	Notes
Frame of Reference UID	(0020,0052)	1	
Position Reference Indicator	(0020,1040)	2	Value as entered at the user interface.

CAUTION

It is possible for the operator of CT LightSpeed QX/i system to change the table height while scanning a series of images. Therefore, implementations must use the Frame of Reference UID (0020,0052) in conjunction with the Table Height (0018,1130) to determine if two images are spatially related.

A.4.13 SC Equipment Module

Attribute Name	Tag	Type	Notes
Modality	(0008,0060)	3	Modality of original image (MR or CT).

A.5 CT Image IOD Private Data Elements Definition

Enclosed is a listing of private data elements used in this implementation for CT Image IOD definition.

A.5.1 Private Creator Identification (GEMS_IDEN_01)

Attribute Name	Tag	VR	VM
Full fidelity	(0009,1001)	LO	1
Suite id	(0009,1002)	SH	1
Product id	(0009,1004)	SH	1
Image actual date	(0009,1027)	SL	1
Equipment UID	(0009,10E3)	UI	1

Note :

For all CT images created by Discovery ST system, (0009,xx01) element will have the value "CT_LIGHTSPEED".

A.5.2 Private Creator Identification (GEMS_ACQU_01)

Attribute Name	Tag	VR	VM
Number of cells I in Detector	(0019,1002)	SL	1
Cell number at Theta	(0019,1003)	DS	1
Cell spacing	(0019,1004)	DS	1
Horiz. Frame of ref.	(0019,100F)	DS	1
Series contrast	(0019,1011)	SS	1
First scan ras	(0019,1018)	LO	1
Last scan ras	(0019,101A)	LO	1
Table speed	(0019,1023)	DS	1
Mid scan time	(0019,1024)	DS	1
Mid scan flag	(0019,1025)	SS	1
Degrees of azimuth	(0019,1026)	SL	1
Gantry period	(0019,1027)	DS	1

Attribute Name	Tag	VR	VM
Number of triggers	(0019,102C)	SL	1
Angle of first view	(0019,102E)	DS	1
Trigger frequency	(0019,102F)	DS	1
Scan FOV type	(0019,1039)	SS	1
Segment number	(0019,1042)	SS	1
Total segments requested	(0019,1043)	SS	1
View compression factor	(0019,1047)	SS	1

Recon post proc. Flag	(0019,1052)	SS	1
Dependent on #views processed	(0019,106A)	SS	1

A.5.3 Private Creator Identification (GEMS_REL_01)

Attribute Name	Tag	VR	VM
Series from which Prescribed	(0021,1003)	SS	1
Series Prescribed From	(0021,1035)	SS	1
Image Prescribed From	(0021,1036)	SS	1
Biopsy position	(0021,1091)	SS	1
Biopsy T location	(0021,1092)	FL	1
Biopsy ref location	(0021,1093)	FL	1

A.5.4 Private Creator Identification (GEMS_STDY_01)

Attribute Name	Tag	VR	VM
Start time(secs) in first axial	(0023,1070)	FD	1

A.5.5 Private Creator Identification (GEMS_IMAG_01)

Attribute Name	Tag	VR	VM
Scout Type	(0027,1010)	SS	1
Vma mamp	(0027,101C)	SL	1
Vma mod	(0027,101E)	SL	1
Vma clip	(0027,101F)	SL	1
Smart scan ON/OFF flag	(0027,1020)	SS	1
Plane Type	(0027,1035)	SS	1
Center R coord of plane image	(0027,1042)	FL	1
Center A coord of plane image	(0027,1043)	FL	1
Center S coord of plane image	(0027,1044)	FL	1
Normal R coord	(0027,1045)	FL	1
Normal A coord	(0027,1046)	FL	1
Normal S coord	(0027,1047)	FL	1
Table start location	(0027,1050)	FL	1
Table end location	(0027,1051)	FL	1

A.5.6 Private Creator Identification (GEMS_PARM_01)

Attribute Name	Tag	VR	VM
Window value	(0043,1010)	US	1
X-ray chain	(0043,1012)	SS	3
Number of overranges	(0043,1016)	SS	5
Delta start time	(0043,101E)	DS	1
Max overranges in a view	(0043,101F)	SL	1
Corrected after glow terms	(0043,1021)	SS	1
Reference channels	(0043,1025)	SS	6
No views ref chans blocked	(0043,1026)	US	6

Scan pitch ratio	(0043,1027)	SH	1
Unique image iden	(0043,1028)	OB	1
Private Scan Options	(0043,102B)	SS	4
RA cord of target recon center	(0043,1031)	DS	2
Trigger on position	(0043,1040)	FL	4
Degree of rotation	(0043,1041)	FL	4
DAS trigger source	(0043,1042)	SL	4
DAS fpa gain	(0043,1043)	SL	4
DAS output source	(0043,1044)	SL	4
DAS ad input	(0043,1045)	SL	4
DAS cal mode	(0043,1046)	SL	4
Start scan to X-ray on delay	(0043,104D)	FL	4
Duration of X-ray on	(0043,104E)	FL	4

A.5.7 Private Creator Identification(GEMS_HELIOS_01)

Attribute Name	Tag	VR	VM
Number of Macro Rows in Detector	(0045, 1001)	SS	1
Macro width at ISO Center	(0045, 1002)	FL	1
DAS type	(0045, 1003)	SS	1
DAS gain	(0045, 1004)	SS	1
DAS Temperature	(0045, 1005)	SS	1
Table Direction	(0045, 1006)	CS	1
Z smoothing Factor	(0045, 1007)	FL	1
View Weighting Mode	(0045, 1008)	SS	1
Sigma Row number	(0045, 1009)	SS	1
Minimum DAS value	(0045, 100A)	FL	1
Maximum Offset Value	(0045, 100B)	FL	1
Number of Views shifted	(0045, 100C)	SS	1
Z tracking Flag	(0045, 100D)	SS	1
Mean Z error	(0045, 100E)	FL	1
Z tracking Error	(0045, 100F)	FL	1
Start View 2A	(0045, 1010)	SS	1
Number of Views 2A	(0045, 1011)	SS	1
Start View 1A	(0045, 1012)	SS	1
Sigma Mode	(0045, 1013)	SS	1
Number of Views 1A	(0045, 1014)	SS	1
Start View 2B	(0045, 1015)	SS	1
Number Views 2B	(0045, 1016)	SS	1
Start View 1B	(0045, 1017)	SS	1
Number of Views 1B	(0045, 1018)	SS	1
Itebone Flag	(0045, 1021)	SS	1
Peristaltic Flag	(0045, 1022)	SS	1
CardiacReconAlgorithm	(0045, 1030)	CS	1
AvgHeartRateForImage	(0045, 1031)	CS	1
TemporalResolution	(0045, 1032)	FL	1
PctRpeakDelay	(0045, 1033)	CS	1

A.5.8 Private Creator Identification (GEMS_CT_CARDIAC_001)

Attribute Name	Tag	VR	VM
CT Cardiac Sequence	(0049, 1001)	SQ	1
HeartRateAtConfirm	(0049, 1002)	CS	1
AvgHeartRatePriorToConfirm	(0049, 1003)	FL	1
MinHeartRatePriorToConfirm	(0049, 1004)	CS	1
MaxHeartRatePriorToConfirm	(0049, 1005)	CS	1
StdDevHeartRatePriorToConfirm	(0049, 1006)	FL	1
NumHeartRateSamplesPriorToConfirm	(0049, 1007)	US	1
AutoHeartRateDetectPredict	(0049, 1008)	CS	1
SystemOptimizedHeartRate	(0049, 1009)	CS	1
EkgMonitorType	(0049, 100A)	ST	1
NumReconSectors	(0049, 100B)	CS	1
RpeakTimeStamps	(0049, 100C)	FL	256

A.5.9 Private Creator Identification (GEMS_CT_VES_01)

Attribute Name	Tag	VR	VM
CTVESSequence	(0051,1001)	SQ	1
VESaccessionNumber	(0008,0050)	SH	1
VESprocedureCodeSequence	(0008,1032)	SQ	1
VESactionItemCodeValue	(0008,0100)	SH	1
VESactionItemCodeScheme	(0008,0102)	SH	1
VESactionItemCodeMeaning	(0008,0104)	LO	1
VESreferenceStudySequence	(0008,1110)	SQ	1
VESRefStudySequenceSopClassUid	(0008,1150)	UI	1
VESRefStudySequenceSopInstanceUid	(0008,1155)	UI	1
VESstudyInstanceUID	(0020,000D)	UI	1
VESrequestedProcedureDescription	(0032,1060)	LO	1
VESrequestedProcedureID	(0040,1001)	SH	1

A.6 MR Image IOD Private Data Elements Definition

A.6.1 Private Creator Identification (GEMS_IDEN_01)

Attribute Name	Tag	VR	VM
Full fidelity	(0009,1001)	LO	1
Suite id	(0009,1002)	SH	1
Product id	(0009,1004)	SH	1
Image actual date	(0009,1027)	SL	1
Service id	(0009,1030)	SH	1
Mobile location number	(0009,1031)	SH	1
Equipment UID	(0009,10E3)	UI	1
Genesis Version - now	(0009,10E6)	SH	1
Exam Record checksum	(0009,10E7)	UL	1
Actual series data time stamp	(0009,10E9)	SL	1

A.6.2 Private Creator Identification (GEMS_PATI_01)

Attribute Name	Tag	VR	VM
Patient Status	(0011,1010)	SS	1

A.6.3 Private Creator Identification (GEMS_ACQU_01)

Attribute Name	Tag	VR	VM
Horiz. Frame of ref.	(0019,100F)	DS	1
Series contrast	(0019,1011)	SS	1
Last pseq	(0019,1012)	SS	1
Series plane	(0019,1017)	SS	1
First scan ras	(0019,1018)	LO	1
First scan location	(0019,1019)	DS	1
Last scan ras	(0019,101A)	LO	1
Last scan loc	(0019,101B)	DS	1
Display field of view	(0019,101E)	DS	1
Acquisition Duration	(0019,105A)	FL	1
Second echo	(0019,107D)	DS	1
Number of echoes	(0019,107E)	SS	1
Table delta	(0019,107F)	DS	1
Contiguous	(0019,1081)	SS	1
Peak SAR	(0019,1084)	DS	1
Monitor SAR	(0019,1085)	SS	1
Cardiac repetition time	(0019,1087)	DS	1
Images per cardiac cycle	(0019,1088)	SS	1
Actual receive gain analog	(0019,108A)	SS	1
Actual receive gain digital	(0019,108B)	SS	1
Delay after trigger	(0019,108D)	DS	1
Swappf	(0019,108F)	SS	1
Pause Interval	(0019,1090)	SS	1
Pulse Time	(0019,1091)	DS	1
Slice offset on freq axis	(0019,1092)	SL	1
Center Frequency	(0019,1093)	DS	1
Transmit Gain	(0019,1094)	SS	1
Analog receiver gain	(0019,1095)	SS	1
Digital receiver gain	(0019,1096)	SS	1
Bitmap defining CVs	(0019,1097)	SL	1
Center freq. Method	(0019,1098)	SS	1
Pulse seq. Mode	(0019,109B)	SS	1
Pulse seq. Name	(0019,109C)	LO	1
Pulse seq. Date	(0019,109D)	DT	1
Internal pulse seq. Name	(0019,109E)	LO	1
Transmitting coil	(0019,109F)	SS	1
Surface Coil Type	(0019,10A0)	SS	1
Extremity Coil flag	(0019,10A1)	SS	1
Raw data run number	(0019,10A2)	SL	1

Calibrated Field strength	(0019,10A3)	UL	1
SAT fat/water/bone	(0019,10A4)	SS	1
Receive bandwidth	(0019,10A5)	DS	1
User data	(0019,10A7)	DS	1
User data	(0019,10A8)	DS	1
User data	(0019,10A9)	DS	1
User data	(0019,10AA)	DS	1
User data	(0019,10AB)	DS	1
User data	(0019,10AC)	DS	1
User data	(0019,10AD)	DS	1
User data	(0019,10AE)	DS	1
User data	(0019,10AF)	DS	1
User data	(0019,10B0)	DS	1
User data	(0019,10B1)	DS	1
User data	(0019,10B2)	DS	1
User data	(0019,10B3)	DS	1
User data	(0019,10B4)	DS	1
User data	(0019,10B5)	DS	1
User data	(0019,10B6)	DS	1
User data	(0019,10B7)	DS	1
User data	(0019,10B8)	DS	1
User data	(0019,10B9)	DS	1
User data	(0019,10BA)	DS	1
User data	(0019,10BB)	DS	1
User data	(0019,10BC)	DS	1
User data	(0019,10BD)	DS	1
Projection angle	(0019,10BE)	DS	1
Saturation planes	(0019,10C0)	SS	1
Surface coil intensity	(0019,10C1)	SS	1
SAT location R	(0019,10C2)	SS	1
SAT location L	(0019,10C3)	SS	1
SAT location A	(0019,10C4)	SS	1
SAT location P	(0019,10C5)	SS	1
SAT location H	(0019,10C6)	SS	1
SAT location F	(0019,10C7)	SS	1
SAT thickness R/L	(0019,10C8)	SS	1
SAT thickness A/P	(0019,10C9)	SS	1
SAT thickness H/F	(0019,10CA)	SS	1
Prescribed flow axis	(0019,10CB)	SS	1
Velocity encoding	(0019,10CC)	SS	1
Thickness disclaimer	(0019,10CD)	SS	1
Prescan type	(0019,10CE)	SS	1
Prescan status	(0019,10CF)	SS	1
Raw data type	(0019,10D0)	SH	1
Projection Algorithm	(0019,10D2)	SS	1
Projection algorithm	(0019,10D3)	SH	1
Fractional echo	(0019,10D5)	SS	1
Prep pulse	(0019,10D6)	SS	1

Cardiac phases	(0019,10D7)	SS	1
Variable echoflag	(0019,10D8)	SS	1
Concatenated SAT	(0019,10D9)	DS	1
User data	(0019,10DF)	DS	1
User data	(0019,10E0)	DS	1
Velocity Encode Scale	(0019,10E2)	DS	1
Fast phases	(0019,10F2)	SS	1
Transmission gain	(0019,10F9)	DS	1

A.6.4 Private Creator Identification (GEMS_RELTA_01)

Attribute Name	Tag	VR	VM
Series from which Prescribed	(0021,1003)	SS	1
Genesis Version - now	(0021,1005)	SH	1
Series Record checksum	(0021,1007)	UL	1
Genesis version – Now	(0021,1018)	SH	1
Acq recon record checksum	(0021,1019)	UL	1
Table start location	(0021,1020)	DS	1
Series from which prescribed	(0021,1035)	SS	1
Image from which prescribed	(0021,1036)	SS	1
Screen Format	(0021,1037)	SS	1
Locations in acquisition	(0021,104F)	SS	1
Graphically prescribed	(0021,1050)	SS	1
Rotation from source x rot	(0021,1051)	DS	1
Rotation from source y rot	(0021,1052)	DS	1
Rotation from source z rot	(0021,1053)	DS	1
Image position	(0021,1054)	SH	3
Image orientation	(0021,1055)	SH	6
Integer slop	(0021,1056)	SL	1
Integer slop	(0021,1057)	SL	1
Integer slop	(0021,1058)	SL	1
Integer slop	(0021,1059)	SL	1
Integer slop	(0021,105A)	SL	1
Float slop	(0021,105B)	DS	1
Float slop	(0021,105C)	DS	1
Float slop	(0021,105D)	DS	1
Float slop	(0021,105E)	DS	1
Float slop	(0021,105F)	DS	1
Auto window/level alpha	(0021,1081)	DS	1
Auto window/level beta	(0021,1082)	DS	1
Auto window/level window	(0021,1083)	DS	1
To window/level level	(0021,1084)	DS	1

A.6.5 Private Creator Identification (GEMS_STDY_01)

Attribute Name	Tag	VR	VM
Number of series in Study	(0023,1001)	SL	1

Number of unarchived Series	(0023,1002)	SL	1
Reference image field	(0023,1010)	SS	1
Summary image	(0023,1050)	SS	1
Start time(secs) in first axial	(0023,1070)	FD	1
No. of updates to header	(0023,1074)	SL	1
Indicates if study has complete info (DICOM/genesis)	(0023,107D)	SS	1

A.6.6 Private Creator Identification (GEMS_SERS_01)

Attribute Name	Tag	VR	VM
Last pulse sequence used	(0025,1006)	SS	1
Images in Series	(0025,1007)	SL	1
Landmark Counter	(0025,1010)	SL	1
Number of Acquisitions	(0025,1011)	SS	1
Indicates no. of updates to header	(0025,1014)	SL	1
Series Complete Flag	(0025,1017)	SL	1
Number of images archived	(0025,1018)	SL	1
Last image number used	(0025,1019)	SL	1
Primary Receiver Suite and Host	(0025,101A)	SH	1

A.6.7 Private Creator Identification (GEMS_IMAG_01)

Attribute Name	Tag	VR	VM
Image archive flag	(0027,1006)	SL	1
Scout Type	(0027,1010)	SS	1
Foreign Image Revision	(0027,1030)	SH	1
Imaging Mode	(0027,1031)	SS	1
Pulse Sequence	(0027,1032)	SS	1
Imaging Options	(0027,1033)	SL	1
Plane Type	(0027,1035)	SS	1
Oblique Plane	(0027,1036)	SL	1
RAS letter of image location	(0027,1040)	SH	1
Image location	(0027,1041)	FL	1
Center R coord of plane image	(0027,1042)	FL	1
Center A coord of plane image	(0027,1043)	FL	1
Center S coord of plane image	(0027,1044)	FL	1
Normal R coord	(0027,1045)	FL	1
Normal A coord	(0027,1046)	FL	1
Normal S coord	(0027,1047)	FL	1
R Coord of Top Right Corner	(0027,1048)	FL	1
A Coord of Top Right Corner	(0027,1049)	FL	1
S Coord of Top Right Corner	(0027,104A)	FL	1
R Coord of Bottom Right Corner	(0027,104B)	FL	1
A Coord of Bottom Right Corner	(0027,104C)	FL	1
S Coord of Bottom Right Corner	(0027,104D)	FL	1
Image dimension - X	(0027,1060)	FL	1

Image dimension - Y	(0027,1061)	FL	1
Number of Excitations	(0027,1062)	FL	1

A.6.8 Private Creator Identification (GEMS_IMPS_01)

Attribute Name	Tag	VR	VM
Lower range of Pixels1	(0029,1015)	SL	1
Lower range of Pixels1	(0029,1016)	SL	1
Lower range of Pixels2	(0029,1017)	SL	1
Upper range of Pixels2	(0029,1018)	SL	1
Len of tot hdr in bytes	(0029,101A)	SL	1
Version of the hdr struct	(0029,1026)	SS	1
Advantage comp. Overflow	(0029,1034)	SL	1
Advantage comp. Underflow	(0029,1035)	SL	1

A.6.9 Private Creator Identification (GEMS_PARM_01)

Attribute Name	Tag	VR	VM
Bitmap of prescan options	(0043,1001)	SS	1
Gradient offset in X	(0043,1002)	SS	1
Gradient offset in Y	(0043,1003)	SS	1
Gradient offset in Z	(0043,1004)	SS	1
Img is original or unoriginal	(0043,1005)	SS	1
Number of EPI shots	(0043,1006)	SS	1
Views per segment	(0043,1007)	SS	1
Respiratory rate, bpm	(0043,1008)	SS	1
Respiratory trigger point	(0043,1009)	SS	1
Type of receiver used	(0043,100A)	SS	1
Peak rate of change of gradient field	(0043,100B)	DS	1
Limits in units of percent	(0043,100C)	DS	1
PSD estimated limit	(0043,100D)	DS	1
PSD estimated limit in tesla per second	(0043,100E)	DS	1
Saravghead	(0043,100F)	DS	1
Window value	(0043,1010)	US	1
GE image integrity	(0043,101C)	SS	1
Level value	(0043,101D)	SS	1
Unique image iden	(0043,1028)	OB	1
Histogram tables	(0043,1029)	OB	1
User defined data	(0043,102A)	OB	1
Private Scan Options	(0043,102B)	SS	4
Effective echo spacing	(0043,102C)	SS	1
String slop field 1	(0043,102D)	SH	1
String slop field 2	(0043,102E)	SH	1
Raw data type	(0043,102F)	SS	1
Raw data type	(0043,1030)	SS	1
RA cord of target recon center	(0043,1031)	DS	2
Raw data type	(0043,1032)	SS	1

Neg_scanspacing	(0043,1033)	FL	1
Offset Frequency	(0043,1034)	IS	1
User_usage_tag	(0043,1035)	UL	1
User_fill_map_MSW	(0043,1036)	UL	1
User_fill_map_LSW	(0043,1037)	UL	1
User25...User48	(0043,1038)	FL	24
Slop_int_6...slop_int_9	(0043,1039)	IS	4

B PET IOD Definitions

B.1 PET Specific IOD Definitions

This section specifies the use of the DICOM PET Image IOD to represent the information included in PET images produced by this implementation. Corresponding attributes are conveyed using the module construct. The contents of this section are:
PET Image IOD Description

PET Image IOD Entity-Relationship Model

PET Image IOD Module Table

PET Image Information Module Definitions

B.1.1 PET IMAGE IOD Implementation

The Discovery ST PET AE implementation of DICOM uses the PET image format when creating image objects. In order to preserve full fidelity when transferring data to a Discovery ST workstation, some specialized database information is encoded as private DICOM attributes. All of the Standard and private attributes used are defined in the module tables. Discovery ST PET AE private data dictionary is included in Section B.2.

B.1.2 PET IMAGE Entity-Relationship Model

The Entity-Relationship diagram for the PET Image interoperability schema is shown in Illustration B.1.2-1. In this figure, the following diagrammatic convention is established to represent the information organization:

- each entity is represented by a rectangular box
- each relationship is represented by a diamond shaped box.
- the fact that a relationship exists between two entities is depicted by lines connecting the corresponding entity boxes to the relationship boxes.

The relationships are fully defined with the maximum number of possible entities in the relationship shown. In other words, the relationship between Series and Image can have up to n Images per Series, but the Patient to Study relationship has 1 Study for each Patient (a Patient can have more than one Study on the system, however each Study will contain all of the information pertaining to that Patient).

ILLUSTRATION B.1.2-1
PET IMAGE ENTITY RELATIONSHIP DIAGRAM

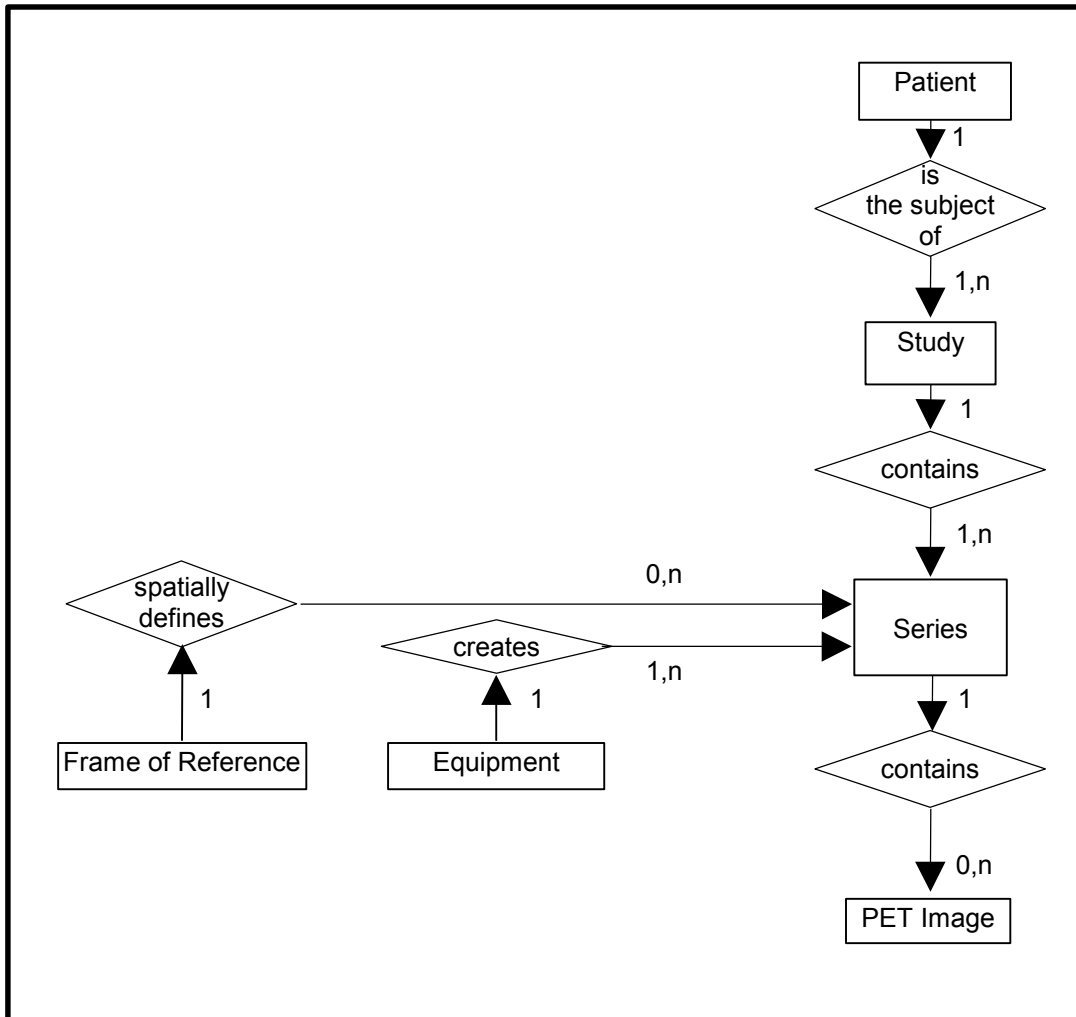

B.1.2.1 ENTITY DESCRIPTIONS

Please refer to DICOM Standard Part 3 (Information Object Definitions) for a description of each of the entities contained within the PET Information Object.

B.1.2.1.1 Patient Entity Description

The Patient Entity defines the characteristics of a patient who is the subject of one or more medical studies which produce medical images.

B.1.2.1.2 Study Entity Description

The Study Entity defines the characteristics of a medical study performed on a patient. A study is a collection of one or more series of medical images which are logically related for the purpose of diagnosing a patient. Each study is associated with exactly one patient.

B.1.2.1.3 Series Entity Description

The Series Entity defines the attributes which are used to group images into distinct logical sets. Each series is associated with exactly one study.

B.1.2.1.4 Equipment Entity Description

The Equipment Entity describes the particular imaging device which produced the series of images. An imaging device may produce one or more series within a study. The Equipment Entity does not describe the data acquisition or image creation Attributes used to generate images within a series.

B.1.2.1.5 Frame of Reference Entity Description

The Frame of Reference Entity identifies the coordinate system which conveys spatial and/or temporal information of images in a series.

B.1.2.1.6 PET Image Entity Description

The PET Image Entity defines the attributes which describe the pixel data of a PET image. The pixel data is generated as a direct result of patient scanning (an ORIGINAL image) or it is derived from an original image through image processing steps (a DERIVED image). An image is defined by its image plane, pixel data characteristics, gray scale and/or color mapping characteristics and modality specific characteristics (acquisition parameters and image creation information).

B.1.2.2 Mapping of DICOM entities

**TABLE 7.1.6.2-1
MAPPING OF DICOM ENTITIES TO DISCOVERY ST PET AE SPECIFIC ENTITIES**

DICOM	<i>Discovery ST PET AE specific Entity</i>
Patient	Patient
Study	Exam
Series	Imageset
Image	Image

B.1.3 PET IMAGE IOD MODULE TABLE

Within an entity of the DICOM PET IOD, attributes are grouped into related set of attributes. A set of related attributes is termed a module. A module facilitates the understanding of the semantics concerning the attributes and how the attributes are related with each other. A module grouping does not infer any encoding of information into datasets.

Table 7.1.11-1 identifies the defined modules within the entities which comprise the DICOM PET IOD. Modules are identified by Module Name.

See DICOM Part 3 for a complete definition of the entities, modules, and attributes.

TABLE 7.1.11-1
PET IMAGE IOD MODULES

Entity Name	Module Name	Reference
Patient	Patient	B.1.4.1.1
	GE Discovery ST PET Patient	B.1.4.1.2
Study	General Study	B.1.4.2.1
	Patient Study	B.1.4.2.2
	GE Discovery ST PET Exam	B.1.4.2.3
Series	General Series	B.1.4.3.1
	PET Series	B.1.4.3.2
	PET Isotope	B.1.4.3.3
	PET Multi-gated Acquisition	B.1.4.3.4
	NM/PET Patient Orientation	B.1.4.3.5
	GE Discovery ST PET Imageset	B.1.4.3.6
	GE Discovery ST PET Scan	B.1.4.3.8
	Frame of Reference	Frame of Reference
Equipment	General Equipment	B.1.4.5.1
Image	General Image	B.1.4.6.1
	Image Plane	B.1.4.6.2
	Image Pixel	B.1.4.6.3
	PET Image	B.1.4.6.4
	Overlay Plane	3.5.6.5
	VOI LUT	B.1.4.6.6
	GE Discovery ST PET Image	B.1.4.6.6
	GE Discovery ST PET Frame	B.1.4.6.8
	GE Discovery ST PET ROI	B.1.4.6.9
	GE Discovery ST PET Annotation	B.1.4.6.10
General Modules	SOP Common	B.1.4.7.1

B.1.4 PET IMAGE INFORMATION MODULE DEFINITIONS

Please refer to DICOM Standard Part 3 (Information Object Definitions) for a description of each of the entities and modules contained within the PET Information Object.

The following modules are included to convey Enumerated Values, Defined Terms, and Optional Attributes supported. Type 1 & Type 2 Attributes are also included for completeness and to define what values they may take and all the attributes are taken from respective tables in GE Discovery ST PET AE Database. It should be noted that they are the same ones as defined in the DICOM Standard Part 3 (Information Object Definitions).

B.1.4.1 Common Patient Entity Modules

B.1.4.1.1 Patient Module

This section specifies the Attributes of the Patient that describe and identify the Patient who is the subject of a diagnostic Study. This Module contains Attributes of the patient that are needed for diagnostic interpretation of the Image and are common for all studies performed on the patient.

**TABLE 2.4-1
PATIENT MODULE ATTRIBUTES**

Attribute Name	Tag	Type	VR	VM	Discovery ST PET Attribute (Discovery ST PET Patient table unless otherwise specified)	Notes
Patient's Name	(0010,0010)	2	PN (64)	1	patient_name	
Patient ID	(0010,0020)	2	LO (64)	1	patient_identifier	
Patient's Birth Date	(0010,0030)	2	DA (26)	1	birthdate	
Patient's Sex	(0010,0040)	2	CS (16)	1	sex	
Referenced Patient Sequence	(0008,1120)	3	SQ	1	Not Used	
>Referenced SOP Class UID	(0008,1150)	1C	UI	1	Not Used	
>Referenced SOP Instance UID	(0008,1155)	1C	UI	1	Not Used	
Patient's Birth Time	(0010,0032)	3	TM	1	Not Used	
Other Patient IDs	(0010,1000)	3	LO	1-n	Not Used	
Other Patient Names	(0010,1001)	3	PN	1-n	Not Used	
Ethnic Group	(0010,2160)	3	SH	1	Not Used	
Patient Comments	(0010,4000)	3	LT	1	Not Used	

B.1.4.1.2 GE Discovery ST PET Patient

Refer to Section B.2.2 for details.

B.1.4.2 Common Study Entity Modules

The following Study IE Modules are common to all Composite Image IODs which reference the Study IE. These Module contain Attributes of the patient and study that are needed for diagnostic interpretation of the image.

B.1.4.2.1 General Study Module

This section specifies the Attributes which describe and identify the Study performed upon the Patient.

**TABLE 2.4-2
GENERAL STUDY MODULE ATTRIBUTES**

Attribute Name	Tag	Type	VR	VM	Discovery ST PET Attribute (GE Discovery ST PET Exam table unless otherwise specified)	Notes
Study Instance UID	(0020,000D)	1	UI	1	study_uid	
Study Date	(0008,0020)	2	DA	1	extract date from exam_datetime	
Study Time	(0008,0030)	2	TM	1	extract time exam_datetime	
Referring Physician's Name	(0008,0090)	2	PN	1	ref_physician	
Study ID	(0020,0010)	2	SH	1	study_identifier	
Accession Number	(0008,0050)	2	SH	1	requisition	
Study Description	(0008,1030)	3	LO	1	exam_desc	
Physician(s) of Record	(0008,1048)	3	PN	1-n	Not Used	
Name of Physician(s) Reading Study	(0008,1060)	3	PN	1-n	diagnostician	
Referenced Study Sequence	(0008,1110)	3	SQ	1	Not Used	
> Referenced SOP Class UID	(0008,1150)	1C	UI	1	Not Used	
> Referenced SOP Instance UID	(0008,1155)	1C	UI	1	Not Used	

B.1.4.2.2 Patient Study Module

This section defines Attributes that provide information about the Patient at the time the Study was performed.

TABLE 2.4-3

PATIENT STUDY MODULE ATTRIBUTES

Attribute Name	Tag	Type	VR	VM	Discovery ST PET Attribute (GE Discovery ST PET Exam table unless otherwise specified)	Notes
Admitting Diagnosis Description	(0008,1080)	3	LO	1-n	Not Used	
Patient's Age	(0010,1010)	3	AS	1	truncate years from (Exam.exam_datetime - Patient.patient_birthdate)	
Patient's Size	(0010,1020)	3	DS	1	patient_ht / 100.0 (convert cm to m)	
Patient's Weight	(0010,1030)	3	DS	1	patient_wt	
Occupation	(0010,2180)	3	SH	1	Not Used	
Additional Patient's History	(0010,21B0)	3	LT	1	patient_history	

B.1.4.2.3 GE Discovery ST PET Exam Module

Refer to Section B.2.3 for details.

B.1.4.3 Common Series Entity Modules

The following Series IE Modules are common to all Composite Image IODs which reference the Series IE.

B.1.4.3.1 General Series Module

This section specifies the Attributes which identify and describe general information about the Series within a Study.

**TABLE 2.4-4
GENERAL SERIES MODULE ATTRIBUTES**

Attribute Name	Tag	Type	VR	VM	Discovery ST PET Attribute (GE Discovery ST PET ImageSet table unless otherwise specified)	Notes
Modality	0008,0060)	1	CS	1	Imageset.modality	
Series Instance UID	(0020,000E)	1	UI	1	IF (SOP Class UID == "1.2.840.113619.4.30") THEN = Scan.scan_id ELSE = image_set_id	
Series Number	0020,0011)	2	IS	1	series_number	
Laterality	0020,0060)	2C	CS	1	Not Used	

Attribute Name	Tag	Type	VR	VM	Discovery ST PET Attribute (GE Discovery ST PET ImageSet table unless otherwise specified)	Notes
Series Date	0008,0021)	3	DA	1	superceded by PET Series.Series Date (0008,0021)	
Series Time	0008,0031)	3	TM	1	superceded by PET Series.Series Time (0008,0031)	
Performing Physician's Name	0008,1050)	3	PN	1-n	Not Used	
Protocol Name	0018,1030)	3	LO	1	Not Used	
Series Description	0008,103E)	3	LO	1	IF (SOP Class UID == "1.2.840.113619.4.30") THEN = Scan.scan_description ELSE = is_description	
Operators' Name	(0008,1070)	3	PN	1-n	Exam.operator	
Referenced Study Component Sequence	(0008,1111)	3	SQ	1	Not Used	
> Referenced SOP Class UID	(0008,1150)	1C	UI	1	Not Used	
> Referenced SOP Instance UID	(0008,1155)	1C	UI	1	Not Used	
Body Part Examined	0018,0015)	3	CS	1	Not Used	
Patient Position	(0018,5100)	2C	CS	1	Scan.patient_position, Frame.patient_entry	
Smallest Pixel Value in Series	(0028,0108)	3	US/SS	1	Not Used	
Largest Pixel Value in Series	(0028,0109)	3	US/SS	1	Not Used	

B.1.4.3.2 PET Series Module

TABLE 2.4-5
PET SERIES MODULE ATTRIBUTES

Attribute Name	Tag	Type	VR	VM	Discovery ST PET Attribute (GE Discovery ST PET ImageSet table unless otherwise specified)	Notes
Series Date	0008,0021)	1	DA	1	extract date from Scan.scan_datetime	
Series Time	(0008,0031)	1	TM	1	extract time from Scan.scan_datetime	
Counts Source	(0054,1002	1	CS	1	Scan.scan_type	

Attribute Name	Tag	Type	VR	VM	Discovery ST PET Attribute (GE Discovery ST PET ImageSet table unless otherwise specified)	Notes
)					
Units	(0054,1001)	1	CS	1	units	
Series Type	(0054,1000)	1	CS	2	is_contents Scan.scan_mode	
Reprojection Method	(0054,1004)	2C	CS	1	is_contents	
Number of R-R Intervals	(0054,0061)	1C	US	1	IF (Scan.scan_mode == [gated]) THEN Count the unique image.image_bin_time for images with Image.image_set_id = thisSOPInstance.ImageSetID ELSE = NULL	
Number of Time Slots	(0054,0071)	1C	US	1	IF (Scan.scan_mode == [gated]) THEN = 1 ELSE = NULL	
Number of Time Slices	(0054,0101)	1C	US	1	Count the unique image.image_time for images with Image.image_set_id = thisSOPInstance.ImageSetID	
Number of Slices	(0054,0081)	1	US	1	Count the unique image.image_location for images with Image.image_set_id = thisSOPInstance.ImageSetID	
Corrected Image	0028,0051)	2	CS	1-n	many	
Randoms Correction Method	(0054,1100)	3	CS	1	IF (Scan.scan_type = [emission] THEN TR 14: emiss_randoms trans_randoms = NULL ELSE TR 14: trans_randoms emiss_randoms = NULL	
Attenuation Correction Method	(0054,1101)	3	LO	1	attenuation atten_coefficient atten_smooth	
Scatter Correction Method	(0054,1105)	3	LO	1	scatter	
Decay Correction	(0054,1102)	1	CS	1	decay	
Reconstruction Diameter	(0018,1100)	3	DS	1	bp_dfov * 10.0 (cm to mm)	

Attribute Name	Tag	Type	VR	VM	Discovery ST PET Attribute (GE Discovery ST PET ImageSet table unless otherwise specified)	Notes
Convolution Kernel	(0018,1210)	3	SH	1-n	many	
Reconstruction Method	(0054,1103)	3	LO	1	recon_method	
Detector Lines of Response Used	(0054,1104)	3	LO	1	axial_angles_used	
Acquisition Start Condition	(0018,0073)	3	CS	1	Scan.start_condition	
Acquisition Start Condition Data	(0018,0074)	3	IS	1	Scan.start_cond_data	
Acquisition Termination Condition	(0018,0071)	3	CS	1	Scan.sel_stop_cond	
Acquisition Termination Condition Data	(0018,0075)	3	IS	1	Scan.sel_stop_cond_data	
Field of View Shape	(0018,1147)	3	CS	1	IF is_type == [native PET images] THEN = "CYLINDRICAL RING"	
Field of View Dimensions	(0018,1149)	3	IS	1-2	10.0*Scan.scan_fov \ Scan.axial_fov	
Gantry /Detector Tilt	(0018,1120)	3	DS	1	Scan.gantry_tilt_angle	
Gantry/Detector Slew	(0018,1121)	3	DS	1		
Type of Detector Motion	(0054,0202)	3	CS	1	IF is_type == [native PET images] THEN = "NONE"	
Collimator Type	(0018,1181)	2	CS	1	Scan.collimation	
Collimator/Grid Name	(0018,1180)	3	SH	1	Not Used	
Axial Acceptance	(0054,1200)	3	DS	1	Scan.axial_acceptance acceptance_flag axial_angle_3d	
Axial Mash	(0054,1201)	3	IS	2	Scan.axial_acceptance acceptance_flag	
Transverse Mash	(0054,1202)	3	IS	1	Scan.theta_compression	
Detector Element Size	(0054,1203)	3	DS	2	Not Used	
Coincidence Window Width	(0054,1210)	3	DS	1	Scan.upper_coinc_limit - Scan.lower_coinc_limit	
Energy Window Range	(0054,0013)	3	SQ	1		

Attribute Name	Tag	Type	VR	VM	Discovery ST PET Attribute (GE Discovery ST PET ImageSet table unless otherwise specified)	Notes
Sequence)					
> Energy Window Lower Limit	(0054,0014)	3	DS	1	Scan.lower_energy_limit	
> Energy Window Upper Limit	(0054,0015)	3	DS	1	Scan.upper_energy_limit	
Secondary Counts Type	(0054,1220)	3	CS	1-n	IF (Scan.delayed_events == [separate]) THEN = "DLYD"	

B.1.4.3.3 PET Isotope Module

**TABLE 2.4-6
PET ISOTOPE MODULE ATTRIBUTES**

Attribute Name	Tag	Type	VR	VM	Discovery ST PET Attribute (GE Discovery ST PET Scan table unless otherwise specified)	Notes
Radiopharmaceutical Information Sequence	(0054,0016)	2	SQ	1	Single item sequence	
> Radionuclide Code Sequence	(0054,0300)	2	SQ	1	Single item sequence	
>> Code Value	(0008,0100)	1C	SH	1	Code value is based on radionuclide_name	
>> Coding Scheme Designator	(0008,0102)	1C	SH	1	99SDM	
>> Code Meaning	(0008,0104)	3	LO	1	radionuclide_name	
> Radiopharmaceutical Route	(0018,1070)	3	LO	1	Not Used	
> Administration Route Code Sequence	(0054,0302)	3	SQ	1	Not Used	
>> Code Value	(0008,0100)	1C	SH	1	Not Used	
>> Coding Scheme Designator	(0008,0102)	1C	SH	1	Not Used	
>> Code Meaning	(0008,0104)	3	LO	1	Not Used	
> Radiopharmaceutical Volume	(0018,1071)	3	DS	1	pre_inj_volume	
> Radiopharmaceutical Start Time	(0018,1072)	3	TM	1	admin_datetime	
> Radiopharmaceutical Stop Time	(0018,1073)	3	TM	1	Not Used	

Attribute Name	Tag	Type	VR	VM	Discovery ST PET Attribute (GE Discovery ST PET Scan table unless otherwise specified)	Notes
> Radionuclide Total Dose	(0018,1074)	3	DS	1	tracer_activity, post_inj_activity, half_life, meas_datetime, admin_datetime, post_inj_datetime	
> Radionuclide Half Life	(0018,1075)	3	DS	1	half_life	
> Radionuclide Positron Fraction	(0018,1076)	3	DS	1	positron_fraction	
> Radiopharmaceutical Specific Activity	(0018,1077)	3	DS	1	Not Used	
> Radiopharmaceutical	(0018,0031)	3	LO	1	tracer_name	
> Radiopharmaceutical Code Sequence	(0054,0304)	3	SQ	1	Single item sequence	
>> Code Value	(0008,0100)	1C	SH	1	Value is based on tracer_name	
>> Coding Scheme Designator	(0008,0102)	1C	SH	1	99SDM	
>> Code Meaning	(0008,0104)	3	LO	1	tracer_name	
Intervention Drug Information Sequence	(0018,0026)	3	SQ	1	Not Used	
> Intervention Drug Name	(0018,0034)	3	LO	1	Not Used	
> Intervention Drug Code Sequence	(0018,0029)	3	SQ	1	Not Used	
>> Code Value	(0008,0100)	1C	SH	1	Not Used	
>> Coding Scheme Designator	(0008,0102)	1C	SH	1	Not Used	
>> Code Meaning	(0008,0104)	3	LO	1	Not Used	
> Intervention Drug Start Time	(0018,0035)	3	TM	1	Not Used	
> Intervention Drug Stop Time	(0018,0027)	3	TM	1	Not Used	
> Intervention Drug Dose	(0018,0028)	3	DS	1	Not Used	

B.1.4.3.4 PET Multi-gated Acquisition Module

TABLE 2.4-7

PET MULTI-GATED ACQUISITION MODULE ATTRIBUTES

Attribute Name	Tag	Type	VR	VM	Discovery ST PET Attribute (GE Discovery ST PET Scan table unless otherwise specified)	Notes
Beat Rejection Flag	(0018,1080)	2	CS	1	IF (trig_rej_method == [none]) THEN = "N" ELSE = "Y"	
Trigger Source or Type	(0018,1061)	3	LO	1	Not Used	
PVC Rejection	(0018,1085)	3	LO	1	trig_rej_method	
Skip Beats	(0018,1086)	3	IS	1	number_for_reject	
Heart Rate	(0018,1088)	3	IS	1	Not Used	
Framing Type	(0018,1064)	3	LO	1	binning_mode	

B.1.4.3.5 NM/PET Patient Orientation Module

**TABLE 2.4-8
NM/PET PATIENT ORIENTATION MODULE ATTRIBUTES**

Attribute Name	Tag	Type	VR	VM	GE Discovery ST PET Attribute	Notes
Patient Orientation Code Sequence	(0054,0410)	2	SQ	1	Zero length sequence	
> Code Value	(0008,0100)	1C	SH	1		
> Coding Scheme Designator	(0008,0102)	1C	SH	1		
> Code Meaning	(0008,0104)	3	LO	1		
> Patient Orientation Modifier Code Sequence	(0054,0412)	2C	SQ	1		
>> Code Value	(0008,0100)	1C	SH	1		
>> Coding Scheme Designator	(0008,0102)	1C	SH	1		
>> Code Meaning	(0008,0104)	3	LO	1		
Patient Gantry Relationship Code Sequence	(0054,0414)	2	SQ	1	Zero length sequence	
> Code Value	(0008,0100)	1C	SH	1		
> Coding Scheme	(0008,0102)	1C	SH	1		

Attribute Name	Tag	Type	VR	VM	GE Discovery ST PET Attribute	Notes
Designator)					
> Code Meaning	(0008,0104)	3	LO	1		

B.1.4.3.6 GE Discovery ST PET ImageSet Module

B.1.4.3.7 Refer to Section B.2.6 for details.

B.1.4.3.8 GE Discovery ST PET Scan Module

Refer to Section B.2.4 for details.

B.1.4.4 Common Frame Of Reference Entity Modules

The following Frame of Reference IE Module is common to all Composite Image IODs which reference the Frame of Reference IE.

B.1.4.4.1 Frame Of Reference Module

This section specifies the Attributes necessary to uniquely identify a frame of reference which insures the spatial relationship of Images within a Series. It also allows Images across multiple Series to share the same Frame Of Reference. This Frame Of Reference (or coordinate system) shall be constant for all Images related to a specific Frame Of Reference.

**TABLE 2.4-9
FRAME OF REFERENCE MODULE ATTRIBUTES**

Attribute Name	Tag	Type	VR	VM	GE Discovery ST PET Attribute	Notes
Frame of Reference UID	(0020,0052)	1	UI	1	IF (ImageSet.for_identifier != NULL) THEN = ImageSet.for_identifier ELSE = idbMakeld()	
Position Reference Indicator	(0020,1040)	2	LO	1	Scan.landmark_name	

B.1.4.5 Common Equipment Entity Modules

The following Equipment IE Module is common to all Composite Image IODs which reference the Equipment IE.

B.1.4.5.1 General Equipment Module

This section specifies the Attributes which identify and describe the piece of equipment which produced a Series of Images.

**TABLE 2.4-10
GENERAL EQUIPMENT MODULE ATTRIBUTES**

Attribute Name	Tag	Type	VR	VM	Discovery ST PET Attribute (GE Discovery ST PET Exam table	Notes

					unless otherwise specified)	
Manufacturer	(0008,0070)	2	LO	1	manufacturer	
Institution Name	(0008,0080)	3	LO	1	hospital_name	
Institution Address	(0008,0081)	3	ST	1	Not Used	
Station Name	(0008,1010)	3	SH	1	Not Used	
Institutional Department Name	(0008,1040)	3	LO	1	Not Used	
Manufacturer's Model Name	(0008,1090)	3	LO	1	scanner_desc	
Device Serial Number	(0018,1000)	3	LO	1		
Software Versions	(0018,1020)	3	LO	1	Image.software_version Curve.software_version Frame.software_version	
Spatial Resolution	(0018,1050)	3	DS	1	Not Used	
Date of Last Calibration	(0018,1200)	3	DA	1-n	Not Used	
Time of Last Calibration	(0018,1201)	3	TM	1-n	Not Used	
Pixel Padding Value	(0028,0120)	3	US or SS	1	Not Used	

B.1.4.6 Common Image Entity Modules

The following Image IE Modules are common to all Composite Image IODs which reference the Image IE.

B.1.4.6.1 General Image Module

This section specifies the Attributes which identify and describe an image within a particular series.

**TABLE 2.4-11
GENERAL IMAGE MODULE ATTRIBUTES**

Attribute Name	Tag	Type	VR	VM	Discovery ST PET Attribute (GE Discovery ST PET Image table unless otherwise specified)	Notes
Image Number	(0020,0013)	2	IS	1	Scan.scan_mode image_location image_time image_bin_time	Refer Note Below

Patient Orientation	(0020,0020)	2C	CS	2	Not Used
Image Date	0008,0023)	2C	DA	1	extract date from image_datetime
Image Time	0008,0033)	2C	TM	1	extract time from image_datetime
Image Type	(0008,0008)	3	CS	1-n	superceded by PET Image.Image Type (08,08)
Acquisition Number	0020,0012)	3	IS	1	Not Used
Acquisition Date	0008,0022)	3	DA	1	superceded by PET Image.Acquisition Date (08,22)
Acquisition Time	0008,0032)	3	TM	1	superceded by PET Image.Acquisition Time (08,32)
Referenced Image Sequence	(0008,1140)	3	SQ	1	Not Used
> Referenced SOP Class UID	(0008,1150)	1C	UI	1	Not Used
> Referenced SOP Instance UID	(0008,1155)	1C	UI	1	Not Used
Derivation Description	(0008,2111)	3	ST	1	truncate ImageSet.derivation to 1024A
Source Image Sequence	(0008,2112)	3	SQ	1	Not Used
> Referenced SOP Class UID	(0008,1150)	1C	UI	1	Not Used
> Referenced SOP Instance UID	(0008,1155)	1C	UI	1	Not Used
Images in Acquisition	0020,1002)	3	IS	1	Not Used
Image Comments	0020,4000)	3	LT	1	Not Used
Lossy Image Compression	0028,2110)	3	CS	1	superceded by PETImage.Lossy Image Compression (28,2110)

NOTE: The Image Number (0020, 0013) is a function of the following four parameters – Scan.scan_mode, image_location, image_time and image_bin_time. Also, the images are to be transferred ONLY after the complete scan is done and not in between frames for the Image Numbers to be correct.

B.1.4.6.2 Image Plane Module

This section specifies the Attributes which define the transmitted pixel array of a two dimensional image plane.

**TABLE 2.4-12
IMAGE PLANE MODULE ATTRIBUTES**

Attribute Name	Tag	Type	VR	VM	Discovery ST PET Attribute (GE Discovery ST PET Image table unless otherwise specified)	Notes
Pixel Spacing	(0028,0030)	1	DS	2	Value 1 = pixel_width Value 2 = pixel_height	
Image Orientation (Patient)	(0020,0037)	1	DS	6	ImageSet.patient_row_cos_l ImageSet.patient_row_cos_p ImageSet.patient_row_cos_s ImageSet.patient_col_cos_l ImageSet.patient_col_cos_p ImageSet.patient_col_cos_s	
Image Position (Patient)	(0020,0032)	1	DS	3	patient_l patient_p patient_s	
Slice Thickness	(0018,0050)	2	DS	1	image_thickness	
Slice Location	(0020,1041)	3	DS	1	image_location	

B.1.4.6.3 Image Pixel Module

This section specifies the Attributes that describe the pixel data of the image.

**TABLE 2.4-13
IMAGE PIXEL MODULE ATTRIBUTES**

Attribute Name	Tag	Type	VR	VM	Discovery ST PET Attribute (GE Discovery ST PET Image table unless otherwise specified)	Notes
Samples per Pixel	(0028,0002)	1	US	1	superceded by PET Image.Samples Per Pixel (28,02)	
Photometric Interpretation	(0028,0004)	1	CS	1	superceded by PET Image.Photometric Interpretation (28,04)	
Rows	(0028,0010)	1	US	1	image_array_height	
Columns	(0028,0011)	1	US	1	image_array_width	
Bits Allocated	(0028,0100)	1	US	1	superceded by PET Image.Bits Allocated (28,100)	
Bits Stored	(0028,0101)	1	US	1	superceded by PET Image.Bits Stored (28,101)	
High Bit	(0028,0102)	1	US	1	superceded by PET Image.High Bit (28,102)	
Pixel Representation	(0028,0103)	1	US	1	= 0001H (2's complement)	

Attribute Name	Tag	Type	VR	VM	Discovery ST PET Attribute (GE Discovery ST PET Image table unless otherwise specified)	Notes
)					
Pixel Data	(7FE0,0010)	1	OB/OW	1	pixel_data (send as OW)	
Planar Configuration	(0028,0006)	1C	US	1	Not Used	
Pixel Aspect Ratio	(0028,0034)	1C	IS	2	Not Used	
Smallest Image Pixel Value	(0028,0106)	3	US/SS	1	Not Used	
Largest Image Pixel Value	(0028,0107)	3	US/SS	1	Not Used	
Red Palette Color Lookup Table Descriptor	(0028,1101)	1C	US/US or SS/US	3	Not Used	
Green Palette Color Lookup Table Descriptor	(0028,1102)	1C	US/US or SS/US	3	Not Used	
Blue Palette Color Lookup Table Descriptor	(0028,1103)	1C	US/US or SS/US	3	Not Used	
Red Palette Color Lookup Table Data	(0028,1201)	1C	US or SS	1-n	Not Used	
Green Palette Color Lookup Table Data	(0028,1202)	1C	US or SS	1-n	Not Used	
Blue Palette Color Lookup Table Data	(0028,1203)	1C	US or SS	1-n	Not Used	

B.1.4.6.4 PET Image Module

This section specifies the Attributes that describe the image within a particular PET Series.

**TABLE 2.4-14
PET IMAGE MODULE ATTRIBUTES**

Attribute Name	Tag	Type	VR	VM	Discovery ST PET Attribute (GE Discovery ST PET Image table unless otherwise specified)	Notes
Image Type	(0008,0008)	3	CS	1-n	Use ImageSet.is_source	
Samples per Pixel	(0028,0002)	1	US	1	1	
Photometric	(0028,0004)	1	CS	1	"MONOCHROME2"	

Attribute Name	Tag	Type	VR	VM	Discovery ST PET Attribute (GE Discovery ST PET Image table unless otherwise specified)	Notes
Interpretation)					
Bits Allocated	(0028,0100)	1	US	1	image_depth (always 16)	
Bits Stored	(0028,0101)	1	US	1	image_depth (always 16)	
High Bit	(0028,0102)	1	US	1	15	
Rescale Intercept	(0028,1052)	1	DS	1	0	
Rescale Slope	(0028,1053)	1	DS	1	Use scale_factor, ImageSet.units	Refer Note Below
Frame Reference Time	(0054,1300)	1	DS	1	IF (frame_ref_time != NULL) THEN = frame_ref_time ELSE = image_time	
Trigger Time	(0018,1060)	1C	DS	1	IF (Scan.scan_mode == [gated]) THEN = image_bin_time ELSE = NULL	
Frame Time	(0018,1063)	1C	DS	1	IF (Scan.scan_mode == [gated]) THEN = image_bin_dur ELSE = NULL	
Low R-R Value	(0018,1081)	1C	IS	1	Scan.lower_reject_limit	
High R-R Value	(0018,1082)	1C	IS	1	Scan.upper_reject_limit	
Lossy Image Compression	(0028,2110)	1C	CS	1	IF (compression == [none]) THEN = 00H ELSE IF (compression == [lossy]) THEN = 01H	
Image Index	(0054,1330)	1	US	1	Scan.scan_mode image_location image_time image_bin_time	
Acquisition Date	(0008,0022)	2	DA	1	= extract date from Scan.scan_datetime + Image.image_time	
Acquisition Time	(0008,0032)	2	TM	1	= extract time from Scan.scan_datetime + Image.image_time	
Actual Frame Duration	(0018,1242)	1C	IS	1	image_duration (Converted from seconds in DB to milliseconds)	

Attribute Name	Tag	Type	VR	VM	Discovery ST PET Attribute (GE Discovery ST PET Image table unless otherwise specified)	Notes
Nominal Interval	(0018,1062)	3	IS	1	Not Used	
Intervals Acquired	(0018,1083)	3	IS	1	Scan.triggers_acquired	
Intervals Rejected	(0018,1084)	3	IS	1	Scan.triggers_rejected	
Primary Counts (Prompts) Accumulated	(0054,1310)	3	IS	1	total_prompts	
Secondary Counts Accumulated	(0054,1311)	3	IS	1-n	Value 1 = total_delays	
Slice Sensitivity Factor	(0054,1320)	3	DS	1	IF (coefficient != NULL) THEN = coefficient ELSE = 1.0	
Decay Factor	(0054,1321)	1C	DS	1	decay_factor	
Dose Calibration Factor	(0054,1322)	3	DS	1	= activity_factor * 1.0e+06 (convert MBq/ml to Bq/ml)	
Scatter Fraction Factor	(0054,1323)	3	DS	1	= scatter_subtracted / total_counts	
Dead Time Factor	(0054,1324)	3	DS	1	deadtime_factor	
Referenced Overlay Sequence	(0008,1130)	3	SQ	1	Not Used	
>Referenced SOP Class UID	(0008,1150)	1	UI	1	Not Used	
>Referenced SOP Instance UID	(0008,1155)	1	UI	1	Not Used	
Referenced Curve Sequence	(0008,1145)	3	SQ	1	Not Used	
>Referenced SOP Class UID	(0008,1150)	1	UI	1	Not Used	
>Referenced SOP Instance UID	(0008,1155)	1	UI	1	Not Used	
Anatomic Region Sequence	(0008,2218)	3	SQ	1	Not Used	
> Code Value	(0008,0100)	1	SH	1	Not Used	
> Coding Scheme Designator	(0008,0102)	1	SH	1	Not Used	
> Code Meaning	(0008,0104)	3	LO	1	Not Used	

Attribute Name	Tag	Type	VR	VM	Discovery ST PET Attribute (GE Discovery ST PET Image table unless otherwise specified)	Notes
> Anatomic Region Modifier Sequence	(0008,2220)	3	SQ	1	Not Used	
>> Code Value	(0008,0100)	1	SH	1	Not Used	
>> Coding Scheme Designator	(0008,0102)	1	SH	1	Not Used	
>> Code Meaning	(0008,0104)	3	LO	1	Not Used	
Primary Anatomic Structure Sequence	(0008,2228)	3	SQ	1	Not Used	
> Code Value	(0008,0100)	1	SH	1	Not Used	
> Coding Scheme Designator	(0008,0102)	1	SH	1	Not Used	
> Code Meaning	(0008,0104)	3	LO	1	Not Used	
> Primary Anatomic Structure Modifier Sequence	(0008,2230)	3	SQ	1	Not Used	
>> Code Value	(0008,0100)	1	SH	1	Not Used	
>> Coding Scheme Designator	(0008,0102)	1	SH	1	Not Used	
>> Code Meaning	(0008,0104)	3	LO	1	Not Used	

Translation of Image.scale_factor (PET Database field)

Image.scale_factor = RescaleSlope (0028,1053) * units_conversion * decay_conversion

where:

If PET Series.Units (0054,1001) is "BQML":

units_conversion = 1.0e-06

Otherwise

units_conversion = 1.0

If PET Series.Decay Correction (0054, 1102) is "ADMIN":

decay_conversion = exp(ln(2) *

(Scan.admin_datetime (0009,103B) - Scan.scan_datetime (0009,100D)) / Scan.half_life

(0009,103F))

Otherwise:

decay_conversion = 1.0

NOTE: Decay correction is typically only applied for Dynamic data, not static/wholebody. In the case of static data, data_conversion field would be 1.0.

B.1.4.6.5 Overlay Plane Module

This section contains Attributes that describe characteristics of an Overlay Plane. Overlay Planes are not currently used in GE Discovery ST PET AE.

**TABLE 2.4-15
OVERLAY PLANE MODULE ATTRIBUTES**

Attribute Name	Tag	Type	VR	VM	Discovery ST PET Attribute (Image table unless otherwise specified)	Notes
None						

B.1.4.6.6 VOI LUT Module

This section specifies the Attributes that describe the VOI LUT.

**TABLE 2.4-16
VOI LUT MODULE ATTRIBUTES**

Attribute Name	Tag	Type	VR	VM	Discovery ST PET Attribute (ImageSet table unless otherwise specified)	Notes
VOI Lut Sequence	(0028,3010)	3	SQ	1	Not Used	
> LUT Descriptor	(0028,3002)	1C	US\US or SS\US	3	Not Used	
> LUT Explanation	(0028,3003)	3	LO	1	Not Used	
> LUT Data	(0028,3006)	1C	US or SS	1-n	Not Used	
Window Center	(0028,1050)	3	DS	1-n	window_center	
Window Width	(0028,1051)	1C	DS	1-n	window_width	
Window Center & Width Explanation	(0028,1055)	3	LO	1-n	Not Used	

B.1.4.6.7 GE Discovery ST PET Image

Refer to Section B.2.7 for details.

B.1.4.6.8 GE Discovery ST PET Frame

Refer to Section B.2.5 for details.

B.1.4.6.9 GE Discovery ST PET ROI

Refer to Section B.2.8 for details.

B.1.4.6.10 GE Discovery ST PET Annotation

Refer to Section B.2.9 for details.

B.1.4.7 General Modules

The SOP Common Module is mandatory for all DICOM IODs.

B.1.4.7.1 SOP Common Module

This section defines the Attributes which are required for proper functioning and identification of the associated SOP Instances. They do not specify any semantics about the Real-World Object represented by the IOD.

**TABLE 2.4-17
SOP COMMON MODULE ATTRIBUTES**

Attribute Name	Tag	Type	VR	VM	Discovery ST PET Attribute (GE Discovery ST PET Image table unless otherwise specified)	Notes
SOP Class UID	(0008,0016)	1	UI	1		TR⁴⁸
SOP Instance UID	(0008,0018)	1	UI	1		TR⁴⁹
Specific Character Set	(0008,0005)	1C	CS	1	= NULL	
Instance Creation Date	(0008,0012)	3	DA	1	current_date	
Instance Creation Time	(0008,0013)	3	TM	1	current_time	
Instance Creator UID	(0008,0014)	3	UI	1	= 1.2.840.113619.1.131.<dbcode>	

T⁴⁸Translate value as follows:

```

IF (PET Image Transfer) THEN
    SOP Class UID (08,16) = 1.2.840.10008.5.1.4.1.1.128
ELSE IF (Secondary Capture Transfer) THEN
    SOP Class UID (08,16) = 1.2.840.10008.5.1.4.1.1
ELSE IF (Curve Transfer) THEN
    CASE ( Curve.curve_type ) OF :
        [ blood sample ], [ rates ] :
            /* PET Curve */
            SOP Class UID (08,16) = 1.2.840.10008.5.1.4.1.1.129
            break;
        [ profile ], [ histogram ], [ volume activity curve ], [ foreign ] :
        [ area ], [ patlak ], [ tac midframe ], [ tac effective ] :
            /* Standalone Curve */
            SOP Class UID (08,16) = 1.2.840.10008.5.1.4.1.1.9
            break;
ELSE IF (Polar Map Transfer) THEN
    Reject Transfer;

```

49 Translate value as follows:

```

IF (SOP Class UID (08,16) == "1.2.840.10008.5.1.4.1.1.128") /* PET Image */
    || /* OR */
IF (SOP Class UID (08,16) == "1.2.840.10008.5.1.4.1.1.17") /* Secondary Capture */
    THEN: SOP Instance UID (08,18) = Image.image_id
ELSE IF (SOP Class UID (08,16) == "1.2.840.10008.5.1.4.1.1.129") THEN /* PET Curve */
    IF (Type of Data (50xx,0020) != "CPM") THEN
        Reject Transfer;
/*Standalone Curve */
ELSE IF (SOP Class UID (08,16) == "1.2.840.10008.5.1.4.1.1.9") THEN
    SOP Instance UID (08,18) = Curve.curve_id
    
```

B.2 Private data dictionary

B.2.1 Private Creator Identification Information

TABLE 2.4-1
PRIVATE CREATOR IDENTIFICATION (GEMS_PETD_01)

Attribute Name	Tag	Type	VR	VM	Discovery ST PET Type
Private Creator Data Element	(0009,0010)	1	SH	1	n/a
GE Discovery ST PET Implementation Version Name	(0009,1001)	3	LO	2	n/a

B.2.2 GE Discovery ST PET Patient Module

TABLE 2.4-2
GE DISCOVERY ST PET PATIENT MODULE PRIVATE ELEMENTS
PRIVATE CREATOR IDENTIFICATION (GEMS_PETD_01)

Attribute Name	Tag	Type	VR	VM	Discovery ST PET Type
GE Discovery ST PET Patient.patient_id	(0009,1002)	3	LO	1	20A
GE Discovery ST PET Patient.compatible_version	(0009,1003)	3	SH	1	5A
GE Discovery ST PET Patient.software_version	(0009,1004)	3	SH	1	5A
GE Discovery ST PET Patient.patient_datetime	(0009,1005)	3	DT	1	D
GE Discovery ST PET Patient.type	(0009,1006)	3	SL	1	L

B.2.3 GE Discovery ST PET Exam Module

TABLE 2.4-3

**GE DISCOVERY ST PET EXAM MODULE PRIVATE ELEMENTS
PRIVATE CREATOR IDENTIFICATION (GEMS_PETD_01)**

Attribute Name	Tag	Type	VR	VM	Discovery ST PET Type
GE Discovery ST PET Exam.exam_id	(0009,1007)	3	UI	1	64A
GE Discovery ST PET Exam.compatible_version	(0009,1008)	3	SH	1	5A
GE Discovery ST PET Exam.software_version	(0009,1009)	3	SH	1	5A

B.2.4 GE Discovery ST PET Scan Module

TABLE 2.4-4

**GE DISCOVERY ST PET SCAN MODULE PRIVATE ELEMENTS
PRIVATE CREATOR IDENTIFICATION (GEMS_PETD_01)**

Attribute Name	Tag	Type	VR	VM	Discovery ST PET Type
GE Discovery ST PET Scan.scan_id	(0009,100A)	3	UI	1	64A
GE Discovery ST PET Scan.compatible_version	(0009,100B)	3	SH	1	5A
GE Discovery ST PET Scan.software_version	(0009,100C)	3	SH	1	5A
GE Discovery ST PET Scan.scan_datetime	(0009,100D)	3	DT	1	D
GE Discovery ST PET Scan.scan_ready	(0009,100E)	3	DT	1	D
GE Discovery ST PET Scan.scan_description	(0009,100F)	3	UI	1	64A
GE Discovery ST PET Scan.hospital_name	(0009,1010)	3	LO	1	32A
GE Discovery ST PET Scan.scanner_desc	(0009,1011)	3	LO	1	32A
GE Discovery ST PET Scan.manufacturer	(0009,1012)	3	LO	1	64A
GE Discovery ST PET Scan.for_identifier	(0009,1013)	3	UI	1	64A
GE Discovery ST PET Scan.landmark_name	(0009,1014)	3	LO	1	64A
GE Discovery ST PET Scan.landmark_abbrev	(0009,1015)	3	SH	1	2A
GE Discovery ST PET	(0009,1016)	3	SL	1	L

Attribute Name	Tag	Type	VR	VM	Discovery ST PET Type
Scan.patient_position					
GE Discovery ST PET Scan.scan_perspective	(0009,1017)	3	SL	1	L
GE Discovery ST PET Scan.scan_type	(0009,1018)	3	SL	1	L
GE Discovery ST PET Scan.scan_mode	(0009,1019)	3	SL	1	L
GE Discovery ST PET Scan.start_condition	(0009,101A)	3	SL	1	L
GE Discovery ST PET Scan.start_cond_data	(0009,101B)	3	SL	1	L
GE Discovery ST PET Scan.sel_stop_cond	(0009,101C)	3	SL	1	L
GE Discovery ST PET Scan.sel_stop_cond_data	(0009,101D)	3	SL	1	L
GE Discovery ST PET Scan.collect_deadtime	(0009,101E)	3	SL	1	L
GE Discovery ST PET Scan.collect_singles	(0009,101F)	3	SL	1	L
GE Discovery ST PET Scan.collect_countrate	(0009,1020)	3	SL	1	L
GE Discovery ST PET Scan.countrate_period	(0009,1021)	3	SL	1	L
GE Discovery ST PET Scan.delayed_events	(0009,1022)	3	SL	1	L
GE Discovery ST PET Scan.delayed_bias	(0009,1023)	3	SL	1	L
GE Discovery ST PET Scan.word_size	(0009,1024)	3	SL	1	L
GE Discovery ST PET Scan.axial_acceptance	(0009,1025)	3	SL	1	L
GE Discovery ST PET Scan.axial_angle_3d	(0009,1026)	3	SL	1	L
GE Discovery ST PET Scan.theta_compression	(0009,1027)	3	SL	1	L
GE Discovery ST PET Scan.axial_compression	(0009,1028)	3	SL	1	L
GE Discovery ST PET Scan.gantry_tilt_angle	(0009,1029)	3	FL	1	F
GE Discovery ST PET Scan.collimation	(0009,102A)	3	SL	1	L
GE Discovery ST PET Scan.scan_fov	(0009,102B)	3	SL	1	L
GE Discovery ST PET Scan.axial_fov	(0009,102C)	3	SL	1	L
GE Discovery ST PET Scan.event_separation	(0009,102D)	3	SL	1	L
GE Discovery ST PET Scan.mask_width	(0009,102E)	3	SL	1	L
GE Discovery ST PET Scan.binning_mode	(0009,102F)	3	SL	1	L
GE Discovery ST PET Scan.trig_rej_method	(0009,1030)	3	SL	1	L

Attribute Name	Tag	Type	VR	VM	Discovery ST PET Type
GE Discovery ST PET Scan.number_for_reject	(0009,1031)	3	SL	1	L
GE Discovery ST PET Scan.lower_reject_limit	(0009,1032)	3	SL	1	L
GE Discovery ST PET Scan.upper_reject_limit	(0009,1033)	3	SL	1	L
GE Discovery ST PET Scan.triggers_acquired	(0009,1034)	3	SL	1	L
GE Discovery ST PET Scan.triggers_rejected	(0009,1035)	3	SL	1	L
GE Discovery ST PET Scan.tracer_name	(0009,1036)	3	LO	1	40A
GE Discovery ST PET Scan.batch_description	(0009,1037)	3	LO	1	40A
GE Discovery ST PET Scan.tracer_activity	(0009,1038)	3	FL	1	F
GE Discovery ST PET Scan.meas_datetime	(0009,1039)	3	DT	1	D
GE Discovery ST PET Scan.pre_inj_volume	(0009,103A)	3	FL	1	F
GE Discovery ST PET Scan.admin_datetime	(0009,103B)	3	DT	1	D
GE Discovery ST PET Scan.post_inj_activity	(0009,103C)	3	FL	1	F
GE Discovery ST PET Scan.post_inj_datetime	(0009,103D)	3	DT	1	D
GE Discovery ST PET Scan.radionuclide_name	(0009,103E)	3	SH	1	6A
GE Discovery ST PET Scan.half_life	(0009,103F)	3	FL	1	F
GE Discovery ST PET Scan.positron_fraction	(0009,1040)	3	FL	1	F
GE Discovery ST PET Scan.source1_holder	(0009,1041)	3	SL	1	L
GE Discovery ST PET Scan.source1_activity	(0009,1042)	3	FL	1	F
GE Discovery ST PET Scan.source1_meas_dt	(0009,1043)	3	DT	1	D
GE Discovery ST PET Scan.source1_radnuclide	(0009,1044)	3	SH	1	6A
GE Discovery ST PET Scan.source1_half_life	(0009,1045)	3	FL	1	F
GE Discovery ST PET Scan.source2_holder	(0009,1046)	3	SL	1	L
GE Discovery ST PET Scan.source2_activity	(0009,1047)	3	FL	1	F
GE Discovery ST PET	(0009,1048)	3	DT	1	D

Attribute Name	Tag	Type	VR	VM	Discovery ST PET Type
Scan.source2_meas_dt					
GE Discovery ST PET Scan.source2_radnuclide	(0009,1049)	3	SH	1	6A
GE Discovery ST PET Scan.source2_half_life	(0009,104A)	3	FL	1	F
GE Discovery ST PET Scan.source_speed	(0009,104B)	3	SL	1	L
GE Discovery ST PET Scan.source_location	(0009,104C)	3	FL	1	F
GE Discovery ST PET Scan.emission_present	(0009,104D)	3	SL	1	L
GE Discovery ST PET Scan.lower_axial_acc	(0009,104E)	3	SL	1	L
GE Discovery ST PET Scan.upper_axial_acc	(0009,104F)	3	SL	1	L
GE Discovery ST PET Scan.lower_coinc_limit	(0009,1050)	3	SL	1	L
GE Discovery ST PET Scan.upper_coinc_limit	(0009,1051)	3	SL	1	L
GE Discovery ST PET Scan.coinc_delay_offset	(0009,1052)	3	SL	1	L
GE Discovery ST PET Scan.coinc_output_mode	(0009,1053)	3	SL	1	L
GE Discovery ST PET Scan.upper_energy_limit	(0009,1054)	3	SL	1	L
GE Discovery ST PET Scan.lower_energy_limit	(0009,1055)	3	SL	1	L
GE Discovery ST PET Scan.normal_cal_id	(0009,1056)	3	UI	1	64A
GE Discovery ST PET Scan.normal_2d_cal_id	(0009,1057)	3	UI	1	64A
GE Discovery ST PET Scan.blank_cal_id	(0009,1058)	3	UI	1	64A
GE Discovery ST PET Scan.wc_cal_id	(0009,1059)	3	UI	1	64A
GE Discovery ST PET Scan.derived	(0009,105A)	3	SL	1	L
GE Discovery ST PET Scan.contrast_agent	(0009,105B)	3	LO	1	64A
GE Discovery ST PET Scan.ctac_conv_scale	(0009, 10D1)	3	LO	1	64A
GE Discovery ST PET Scan.vqc_x_axis_trans	(0009, 10CB)	3	FL	1	F
GE Discovery ST PET Scan.vqc_x_axis_tilt	(0009, 10CC)	3	FL	1	F
GE Discovery ST PET Scan.vqc_y_axis_trans	(0009, 10CD)	3	FL	1	F

Attribute Name	Tag	Type	VR	VM	Discovery ST PET Type
GE Discovery ST PET Scan.vqc_y_axis_swivel	(0009, 10CE)	3	FL	1	F
GE Discovery ST PET Scan.vqc_z_axis_trans	(0009, 10CF)	3	FL	1	F
GE Discovery ST PET Scan.vqc_z_axis_roll	(0009, 10D0)	3	FL	1	F

B.2.5 GE Discovery ST PET Frame Module

TABLE 2.4-5

**GE DISCOVERY ST PET FRAME MODULE PRIVATE ELEMENTS
PRIVATE CREATOR IDENTIFICATION (GEMS_PETD_01)**

Attribute Name	Tag	Type	VR	VM	Discovery ST PET Type
GE Discovery ST PET Frame.frame_id	(0009,105C)	3	UI	1	64A
GE Discovery ST PET Frame.scan_id	(0009,105D)	3	UI	1	64A
GE Discovery ST PET Frame.exam_id	(0009,105E)	3	UI	1	64A
GE Discovery ST PET Frame.patient_id	(0009,105F)	3	LO	1	20A
GE Discovery ST PET Frame.compatible_version	(0009,1060)	3	SH	1	5A
GE Discovery ST PET Frame.software_version	(0009,1061)	3	SH	1	5A
GE Discovery ST PET Frame.where_is_frame	(0009,1062)	3	ST	1	256A
GE Discovery ST PET Frame.frame_size	(0009,1063)	3	SL	1	L
GE Discovery ST PET Frame.file_exists	(0009,1064)	3	SL	1	L
GE Discovery ST PET Frame.patient_entry	(0009,1065)	3	SL	1	L
GE Discovery ST PET Frame.table_height	(0009,1066)	3	FL	1	F
GE Discovery ST PET Frame.table_z_position	(0009,1067)	3	FL	1	F
GE Discovery ST PET Frame.landmark_datetime	(0009,1068)	3	DT	1	D
GE Discovery ST PET Frame.slice_count	(0009,1069)	3	SL	1	L
GE Discovery ST PET Frame.start_location	(0009,106A)	3	FL	1	F
GE Discovery ST PET Frame.acq_delay	(0009,106B)	3	SL	1	L
GE Discovery ST PET Frame.acq_start	(0009,106C)	3	DT	1	D
GE Discovery ST PET Frame.acq_duration	(0009,106D)	3	SL	1	L

GE Discovery ST PET Frame.acq_bin_dur	(0009,106E)	3	SL	1	L
GE Discovery ST PET Frame.acq_bin_start	(0009,106F)	3	SL	1	L
GE Discovery ST PET Frame.actual_stop_cond	(0009,1070)	3	SL	1	L
GE Discovery ST PET Frame.total_prompts	(0009,1071)	3	FD	1	Dbl
GE Discovery ST PET Frame.total_delays	(0009,1072)	3	FD	1	Dbl
GE Discovery ST PET Frame.frame_valid	(0009,1073)	3	SL	1	L
GE Discovery ST PET Frame.validity_info	(0009,1074)	3	SL	1	L
GE Discovery ST PET Frame.archived	(0009,1075)	3	SL	1	L
GE Discovery ST PET Frame.compression	(0009,1076)	3	SL	1	L
GE Discovery ST PET Frame.uncompressed_size	(0009,1077)	3	SL	1	L
GE Discovery ST PET Frame.accum_bin_dur	(0009,1078)	3	SL	1	L

B.2.6 GE Discovery ST PET ImageSet Module

TABLE 2.4-6

**GE DISCOVERY ST PET IMAGESET MODULE PRIVATE ELEMENTS
PRIVATE CREATOR IDENTIFICATION (GEMS_PETD_01)**

Attribute Name	Tag	Type	VR	VM	Discovery ST PET Type
GE Discovery ST PET ImageSet.compatible_version	(0009,1079)	3	SH	1	5A
GE Discovery ST PET ImageSet.software_version	(0009,107A)	3	SH	1	5A
GE Discovery ST PET ImageSet.is_datetime	(0009,107B)	3	DT	1	D
GE Discovery ST PET ImageSet.is_source	(0009,107C)	3	SL	1	L
GE Discovery ST PET ImageSet.is_contents	(0009,107D)	3	SL	1	L
GE Discovery ST PET ImageSet.is_type	(0009,107E)	3	SL	1	L
GE Discovery ST PET ImageSet.is_reference	(0009,107F)	3	FL	3	F
GE Discovery ST PET ImageSet.multi_patient	(0009,1080)	3	SL	1	L
GE Discovery ST PET ImageSet.number_of_normals	(0009,1081)	3	SL	1	L
GE Discovery ST PET ImageSet.color_map_id	(0009,1082)	3	UI	1	64A

Attribute Name	Tag	Type	VR	VM	Discovery ST PET Type
GE Discovery ST PET ImageSet.window_level_type	(0009,1083)	3	SL	1	L
GE Discovery ST PET ImageSet.rotate	(0009,1084)	3	FL	1	F
GE Discovery ST PET ImageSet.flip	(0009,1085)	3	SL	1	L
GE Discovery ST PET ImageSet.zoom	(0009,1086)	3	FL	1	F
GE Discovery ST PET ImageSet.pan_x	(0009,1087)	3	SL	1	L
GE Discovery ST PET ImageSet.pan_y	(0009,1088)	3	SL	1	L
GE Discovery ST PET ImageSet.window_level_min	(0009,1089)	3	FL	1	F
GE Discovery ST PET ImageSet.window_level_max	(0009,108A)	3	FL	1	F
GE Discovery ST PET ImageSet.recon_method	(0009,108B)	3	SL	1	L
GE Discovery ST PET ImageSet.attenuation	(0009,108C)	3	SL	1	L
GE Discovery ST PET ImageSet.atten_coefficient	(0009,108D)	3	FL	1	F
GE Discovery ST PET ImageSet.bp_filter	(0009,108E)	3	SL	1	L
GE Discovery ST PET ImageSet.bp_filter_cutoff	(0009,108F)	3	FL	1	F
GE Discovery ST PET ImageSet.bp_filter_order	(0009,1090)	3	SL	1	L
GE Discovery ST PET ImageSet.bp_center_l	(0009,1091)	3	FL	1	F
GE Discovery ST PET ImageSet.bp_center_p	(0009,1092)	3	FL	1	F
GE Discovery ST PET ImageSet.atten_smooth	(0009,1093)	3	SL	1	L
GE Discovery ST PET ImageSet.atten_smooth_param	(0009,1094)	3	SL	1	L
GE Discovery ST PET ImageSet.angle_smooth_param	(0009,1095)	3	SL	1	L
GE Discovery ST PET ImageSet.wellcountercal_id	(0009,1096)	3	UI	1	64A
GE Discovery ST PET ImageSet.trans_scan_id	(0009,1097)	3	UI	1	64A
GE Discovery ST PET ImageSet.norm_cal_id	(0009,1098)	3	UI	1	64A
GE Discovery ST PET ImageSet.blk_cal_id	(0009,1099)	3	UI	1	64A
GE Discovery ST PET	(0009,109A)	3	FL	1	F

Attribute Name	Tag	Type	VR	VM	Discovery ST PET Type
ImageSet.cac_edge_threshold					
GE Discovery ST PET ImageSet.cac_skull_offset	(0009,109B)	3	FL	1	F
GE Discovery ST PET ImageSet.emiss_sub_id	(0009,109C)	3	UI	1	64A
GE Discovery ST PET ImageSet.radial_filter_3d	(0009,109D)	3	SL	1	L
GE Discovery ST PET ImageSet.radial_cutoff_3d	(0009,109E)	3	FL	1	F
GE Discovery ST PET ImageSet.axial_filter_3d	(0009,109F)	3	SL	1	L
GE Discovery ST PET ImageSet.axial_cutoff_3d	(0009,10A0)	3	FL	1	F
GE Discovery ST PET ImageSet.axial_start	(0009,10A1)	3	FL	1	F
GE Discovery ST PET ImageSet.axial_spacing	(0009,10A2)	3	FL	1	F
GE Discovery ST PET ImageSet.axial_angles_used	(0009,10A3)	3	SL	1	L
GE Discovery ST PET ImageSet.ir_num_iterations	(0009,10B2)	3	SL	1	F
GE Discovery ST PET ImageSet.ir_num_subsets	(0009,10B3)	3	SL	1	L
GE Discovery ST PET ImageSet.ir_recon_fov	(0009,10B4)	3	FL	1	F
GE Discovery ST PET ImageSet.ir_corr_model	(0009,10B5)	3	SL	1	L
GE Discovery ST PET ImageSet.ir_loop_filter	(0009,10B6)	3	SL	1	L
GE Discovery ST PET ImageSet.ir_pre_filt_parm	(0009,10B7)	3	FL	1	F
GE Discovery ST PET ImageSet.ir_loop_filt_parm	(0009,10B8)	3	SL	1	L
GE Discovery ST PET ImageSet.response_filt_parm	(0009,10B9)	3	FL	1	F
GE Discovery ST PET ImageSet.post_filter	(0009,10BA)	3	SL	1	L
GE Discovery ST PET ImageSet.post_filt_parm	(0009,10BB)	3	FL	1	F
GE Discovery ST PET ImageSet.ir_regularize	(0009,10BC)	3	SL	1	L
GE Discovery ST PET ImageSet.regularize_parm	(0009,10BD)	3	FL	1	F

Attribute Name	Tag	Type	VR	VM	Discovery ST PET Type
GE Discovery ST PET ImageSet.ac_bp_filter	(0009,10BE)	3	SL	1	L
GE Discovery ST PET ImageSet.ac_bp_filt_cut_off	(0009,10BF)	3	FL	1	F
GE Discovery ST PET ImageSet.ac_bp_filt_order	(0009,10C0)	3	SL	1	L
GE Discovery ST PET ImageSet.ac_img_smooth	(0009,10C1)	3	SL	1	L
GE Discovery ST PET ImageSet.ac_img_smooth_parm	(0009,10C2)	3	FL	1	F
GE Discovery ST PET ImageSet.scatter_method	(0009,10C3)	3	SL	1	L
GE Discovery ST PET ImageSet.scatter_num_iter	(0009,10C4)	3	SL	1	L
GE Discovery ST PET ImageSet.scatter_parm	(0009,10C5)	3	FL	1	F
GE Discovery ST PET imageset.ctac_conv_scale	(0009, 10D4)	3	LO	1	L

B.2.7 GE Discovery ST PET Image Module

TABLE 2.4-7

**GE DISCOVERY ST PET IMAGE MODULE PRIVATE ELEMENTS
PRIVATE CREATOR IDENTIFICATION (GEMS_PETD_01)**

Attribute Name	Tag	Type	VR	VM	Discovery ST PET Type
GE Discovery ST PET Image.compatible_version	(0009,10A4)	3	SH	1	5A
GE Discovery ST PET Image.software_version	(0009,10A5)	3	SH	1	5A
GE Discovery ST PET Image.slice_number	(0009,10A6)	3	SL	1	L
GE Discovery ST PET Image.total_counts	(0009,10A7)	3	FL	1	F
GE Discovery ST PET Image.other_atts	(0009,10A8)	3	OB	1	Bt
GE Discovery ST PET Image.other_atts_size	(0009,10A9)	3	SL	1	L
GE Discovery ST PET Image.archived	(0009,10AA)	3	SL	1	L
GE Discovery ST PET Image.bp_center_x	(0009,10AB)	3	FL	1	F
GE Discovery ST PET Image.bp_center_y	(0009,10AC)	3	FL	1	F
GE Discovery ST PET Image.trans_frame_id	(0009,10AD)	3	UI	1	64A

Attribute Name	Tag	Type	VR	VM	Discovery ST PET Type
GE Discovery ST PET Image.tpluse_frame_id	(0009,10AE)	3	UI	1	64A
GE Discovery ST PET Image.seg_qc_parm	(0009,10C6)	3	FL	1	F
GE Discovery ST PET Image.overlap	(0009,10C7)	3	SL	1	L
GE Discovery ST PET Image.ovlp_frm_id	(0009,10C8)	3	UI	1	64A
GE Discovery ST PET Image.ovlp_trans_frm_id	(0009,10C9)	3	UI	1	64A
GE Discovery ST PET Image.ovlp_tpulse_frm_id	(0009,10CA)	3	UI	1	64A

B.2.8 GE Discovery ST PET ROI Module

TABLE 2.4-8

**GE DISCOVERY ST PET ROI MODULE PRIVATE ELEMENTS
PRIVATE CREATOR IDENTIFICATION (GEMS_PETD_01)**

Attribute Name	Tag	Type	VR	VM	Discovery ST PET Type
Private Creator Data Element	(0011,0010)	1	SH	1	n/a
GE Discovery ST PET ROI Sequence	(0011,1001)	3	SQ	1	n/a
> GE Discovery ST PET ROI.roi_id	(0011,1002)	3	UI	1	64A
> GE Discovery ST PET ROI.image_id	(0011,1003)	3	UI	1	64A
> GE Discovery ST PET ROI.compatible_version	(0011,1004)	3	SH	1	5A
> GE Discovery ST PET ROI.software_version	(0011,1005)	3	SH	1	5A
> GE Discovery ST PET ROI.roi_name	(0011,1006)	3	LO	1	32A
> GE Discovery ST PET ROI.roi_datetime	(0011,1007)	3	DT	1	D
> GE Discovery ST PET ROI.roi_type	(0011,1008)	3	SL	1	L
> GE Discovery ST PET ROI.center_x	(0011,1009)	3	FL	1	F
> GE Discovery ST PET ROI.center_y	(0011,100A)	3	FL	1	F
> GE Discovery ST PET ROI.width	(0011,100B)	3	FL	1	F
> GE Discovery ST PET ROI.height	(0011,100C)	3	FL	1	F
> GE Discovery ST PET ROI.angle	(0011,100D)	3	FL	1	F
> GE Discovery ST PET ROI.number_of_points	(0011,100E)	3	SL	1	L
> GE Discovery ST PET ROI.roi_data	(0011,100F)	3	OB	1	Bt
> GE Discovery ST PET ROI.roi_size	(0011,1010)	3	SL	1	L
> GE Discovery ST PET ROI.color	(0011,1011)	3	LO	1	20A
> GE Discovery ST PET ROI.line_type	(0011,1012)	3	SL	1	L

> GE Discovery ST PET ROI.line_width	(0011,1013)	3	SL	1	L
> GE Discovery ST PET ROI.roi_number	(0011,1014)	3	SL	1	L
> GE Discovery ST PET ROI.convex	(0011,1015)	3	SL	1	L
> GE Discovery ST PET ROI.atten_corr_flag	(0011,1016)	3	SL	1	L

B.2.9 GE Discovery ST PET Annotation Module

TABLE 2.4-9

**GE DISCOVERY ST PET ANNOTATION MODULE PRIVATE ELEMENTS
PRIVATE CREATOR IDENTIFICATION (GEMS_PETD_01)**

Attribute Name	Tag	Type	VR	VM	GE Discovery ST PET Type
Private Creator Data Element	(0013,0010)	1	SH	1	n/a
GE Discovery ST PET Annotation Sequence	(0013,1001)	3	SQ	1	n/a
> GE Discovery ST PET Annotation.annotation_id	(0013,1002)	3	UI	1	64A
> GE Discovery ST PET Annotation.image_id	(0013,1003)	3	UI	1	64A
> GE Discovery ST PET Annotation.compatible_version	(0013,1004)	3	SH	1	5A
> GE Discovery ST PET Annotation.software_version	(0013,1005)	3	SH	1	5A
> GE Discovery ST PET Annotation.type	(0013,1006)	3	SL	1	L
> GE Discovery ST PET Annotation.font_name	(0013,1007)	3	LO	1	32A
> GE Discovery ST PET Annotation.font_size	(0013,1008)	3	SH	1	2A
> GE Discovery ST PET Annotation.foreground_color	(0013,1009)	3	LO	1	20A
> GE Discovery ST PET Annotation.background_color	(0013,100A)	3	LO	1	20A
> GE Discovery ST PET Annotation.coordinate_system	(0013,100B)	3	SL	1	L
> GE Discovery ST PET Annotation.start_x	(0013,100C)	3	FL	1	F
> GE Discovery ST PET Annotation.start_y	(0013,100D)	3	FL	1	F
> GE Discovery ST PET Annotation.end_x	(0013,100E)	3	FL	1	F
> GE Discovery ST PET Annotation.end_y	(0013,100F)	3	FL	1	F
> GE Discovery ST PET Annotation.start_symbol	(0013,1010)	3	SL	1	L
> GE Discovery ST PET Annotation.end_symbol	(0013,1011)	3	SL	1	L
> GE Discovery ST PET Annotation.annotation_data	(0013,1012)	3	OB	1	Bt
> GE Discovery ST PET Annotation.annotation_size	(0013,1013)	3	SL	1	L

> GE Discovery ST PET Annotation.label_id	(0013,1014)	3	LO	1	64A
---	-------------	---	----	---	-----

B.3 Private Data Elements

Enclosed is a listing of private data elements used in this implementation for CT/MR Image IOD definition.

C DICOMDIR Directory Information

Enclosed here is a listing of only the optional (conditional) modules and optional attributes used by this implementation in the DICOMDIR definition. All standard attributes as defined in Part 3 Addendum (Basic Directory Information Object) are supported by this implementation but not listed here.

C.1 Basic Directory IOD Definition

Module	Reference	Usage	Notes
Directory Information	B.X.3.2.1 (DICOM PS3.10)	U	

C.2 Directory Information Module

Attribute Name	Tag	Type	Notes
Offset of the Next Directory Record	(0004,1400)	1C	
Record In-use Flag	(0004,1410)	1C	
Offset of Referenced Lower-Level Directory Entity	(0004,1420)	1C	
Directory Record Type	(0004,1430)	1C	PATIENT, STUDY, SERIES and IMAGE
Referenced File ID	(0004,1500)	1C	Present only in IMAGE Directory Record
Referenced SOP Class UID in file	(0004,1510)	1C	Present only in IMAGE Directory Record
Referenced SOP Instance UID in File	(0004,1511)	1C	Present only in IMAGE Directory Record
Referenced Transfer Syntax UID in File	(0004,1512)	1C	Present only in IMAGE Directory Record

C.3 Directory Record Selection Keys

As indicated in table C.1.2, the PRI-CTMR-MOD12 application profile will have only the Patient, Study, Series and Image directory record types. Given below are the list of attributes supported under each of these directories.

C.3.1 Patient Keys

Attribute Name	Tag	Type	Notes
Specific Character Set	(0008,0005)	1C	ISO_IR 100
Patient's Name	(0010,0010)	2	
Patient ID	(0010,0020)	1	

C.3.2 Study Keys

Attribute Name	Tag	Type	Notes
Specific Character Set	(0008,0005)	1C	ISO_IR 100
Study Date	(0008,0020)	1	
Study Time	(0008,0030)	1	
Accession Number	(0008,0050)	2	
Study Description	(0008,1030)	2	
Study Instance UID	(0020,000D)	1C	
Study ID	(0020,0010)	1	

C.3.3 Series Keys

Attribute Name	Tag	Type	Notes
Specific Character Set	(0008,0005)	1C	ISO_IR 100
Image Type	(0008,0008)	3	
Modality	(0008,0060)	1	
Manufacturer's Id	(0008,0070)	3	
Series Description	(0008,103E)	3	
Manuf. Model Name	(0008,1090)	3	
Series Instance UID	(0020,000E)	1	
Series Number	(0020,0011)	1	

C.3.4 Image Keys

Attribute Name	Tag	Type	Notes
Specific Character Set	(0008,0005)	1C	ISO_IR 100
SOP Instance UID	(0008,0018)	3	Redundant to (0004,1511)
Referenced Image Sequence	(0008,1140)	1C	Not included.
Sequence Variant	(0018,0021)	3	
Slice Thickness	(0018,0050)	3	
Repetition Time	(0018,0080)	3	
Echo Time	(0018,0081)	3	
Inversion Time	(0018,0082)	3	
Number of Averages	(0018,0083)	3	
Echo Number	(0018,0086)	3	MRI profile only.
Spacing Between Slices	(0018,0088)	3	
Data Collection Diameter	(0018,0090)	3	
Contrast/Bolus Route	(0018,1040)	3	
Trigger Time	(0018,1060)	3	
Reconstruction Diameter	(0018,1100)	3	

Gantry/Detector Tilt	(0018,1120)	3	
Convolution Kernel	(0018,1210)	3	
Flip Angle	(0018,1314)	3	
Image Number	(0020,0013)	1	
Image Position (Patient)	(0020,0032)	1C	
Image Orientation (Patient)	(0020,0037)	1C	
Frame of Reference UID	(0020,0052)	1C	Absent from PRI-CTMR-MOD12
Slice Location	(0020,1041)	3	
Samples Per Pixel	(0028,0002)	R	
Photometric Interpretation	(0028,0004)	R	Absent from all profiles.
Rows	(0028,0010)	1	
Columns	(0028,0011)	1	
Pixel Spacing	(0028,0030)	1C	
Bits Allocated	(0028,0100)	R	
Bits Stored	(0028,0101)	R	MRI – Absent from profiles.
High Bit	(0028,0102)	R	MRI – Absent from profiles.

D Standalone PET curve INFORMATION OBJECT IMPLEMENTATION

D.1 introduction

This section specifies the use of the DICOM Standalone PET Curve IOD (referred to as the PET Curve IOD in other parts of this section) to represent the information included in PET curves produced by this implementation. Corresponding attributes are conveyed using the module construct. The contents of this section are:

D.2- IOD Description

D.3- IOD Entity-Relationship Model

D.4- IOD Module Table

D.5- IOD Module Definition

D.2 PET Curve IOD Implementation

The GE Discovery ST PET AE implementation of DICOM uses the PET Curve format when creating curve objects. In order to preserve full fidelity when transferring data to a GE Discovery ST PET AE workstation, some specialized database information is encoded as private DICOM attributes. All of the Standard and private attributes used are defined in the module tables. The GE Discovery ST PET AE private data dictionary is included in Section D.6. Nevertheless, the GE Discovery ST PET AE is able to process PET DICOM curves without any private data elements.

D.3 PET curve Entity-Relationship Model

The Entity-Relationship diagram for the PET Curve interoperability schema is shown in **Illustration 6-1**. In this figure, the following diagrammatic convention is established to represent the information organization:

- each entity is represented by a rectangular box
- each relationship is represented by a diamond shaped box.
- the fact that a relationship exists between two entities is depicted by lines connecting the corresponding entity boxes to the relationship boxes.

The relationships are fully defined with the maximum number of possible entities in the relationship shown. In other words, the relationship between Series and Curve can have up to n Curves per Series, but the Patient to Study relationship has 1 Study for each Patient (a Patient can have more than one Study on the system, however each Study will contain all of the information pertaining to that Patient).

ILLUSTRATION 6-1
PET CURVE ENTITY RELATIONSHIP DIAGRAM

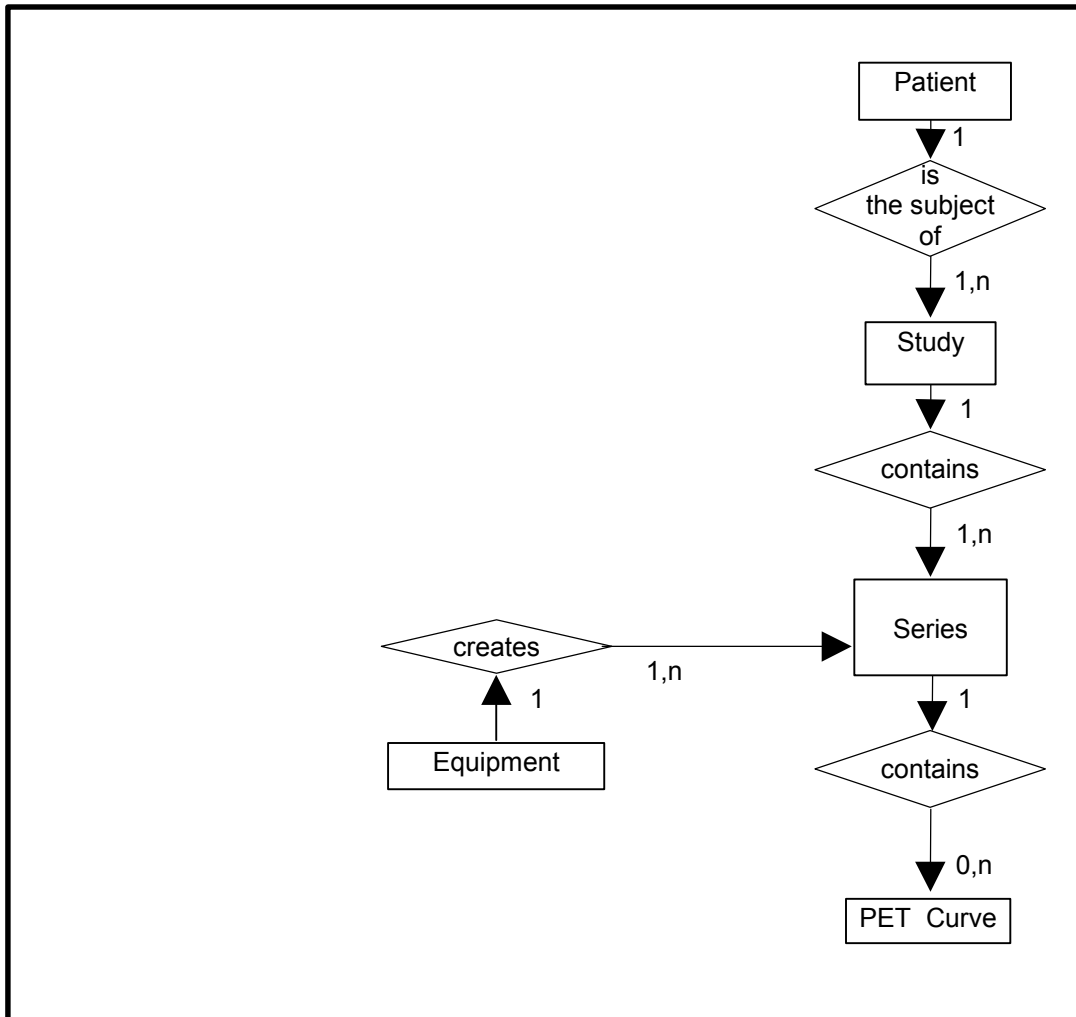

D.3.1 ENTITY DESCRIPTIONS

Please refer to DICOM Standard Part 3 (Information Object Definitions) for a description of each of the entities contained within the PET Information Object.

D.3.1.1 Patient Entity Description

The Patient Entity defines the characteristics of a patient who is the subject of one or more medical studies which produce medical images.

D.3.1.2 Study Entity Description

The Study Entity defines the characteristics of a medical study performed on a patient. A study is a collection of one or more series of medical images which are logically related for the purpose of diagnosing a patient. Each study is associated with exactly one patient.

D.3.1.3 Series Entity Description

The Series Entity defines the attributes which are used to group images into distinct logical sets. Each series is associated with exactly one study.

D.3.1.4 Equipment Entity Description

The Equipment Entity describes the particular imaging device which produced the series of images. An imaging device may produce one or more series within a study. The Equipment Entity does not describe the data acquisition or image creation Attributes used to generate images within a series.

D.3.1.5 PET Curve Entity Description

The PET Curve Entity defines the attributes which describe the curve data of a PET curve.

D.3.2 GE Discovery ST PET AE Mapping of DICOM entities

TABLE 2.4-1
MAPPING OF DICOM ENTITIES TO DISCOVERY ST PET ENTITIES

DICOM	Discovery ST PET Entity
Patient	Patient
Study	Exam
Series	Imageset
Curve	Curve, Graph, Curve Presentation

D.4 PET CURVE IOD MODULE TABLE

Within an entity of the DICOM PET IOD, attributes are grouped into related set of attributes. A set of related attributes is termed a module. A module facilitates the understanding of the semantics concerning the attributes and how the attributes are related with each other. A module grouping does not infer any encoding of information into datasets.

Table 2.4-1 identifies the defined modules within the entities which comprise the DICOM PET IOD. Modules are identified by Module Name.

See DICOM Part 3 for a complete definition of the entities, modules, and attributes.

**TABLE 2.4-1
PET CURVE IOD MODULES**

Entity Name	Module Name	Reference
Patient	Patient	D.5.1.1
	GE Discovery ST PET Patient	D.5.1.2
Study	General Study	D.5.2.1
	Patient Study	D.5.2.2
	GE Discovery ST PET Exam	D.5.2.3
Series	General Series	D.5.3.1
	PET Series	D.5.3.2
	PET Isotope	D.5.3.3
	PET Multi-gated Acquisition	D.5.3.4
	GE Discovery ST PET Imageset	D.5.3.5
	GE Discovery ST PET Scan	D.5.3.6
Equipment	General Equipment	D.5.4.1
Curve	Curve Identification	D.5.5.1
	Curve	D.5.5.2
	PET Curve	D.5.5.3
	GE Discovery ST PET Curve	D.5.5.4
	GE Discovery ST PET Graph	D.5.5.5
	GE Discovery ST PET Curve Presentation	D.5.5.6
General Modules	SOP Common	D.5.6.1

D.5 PET CURVE INFORMATION MODULE DEFINITIONS

Please refer to DICOM Standard Part 3 (Information Object Definitions) for a description of each of the entities and modules contained within the PET Information Object.

The following modules are included to convey Enumerated Values, Defined Terms, and Optional Attributes supported. Type 1 & Type 2 Attributes are also included for completeness and to define what values they may take and where these values are obtained from. It should be noted that they are the same ones as defined in the DICOM Standard Part 3 (Information Object Definitions).

D.5.1 Common Patient Entity Modules

D.5.1.1 Patient Module

This section specifies the Attributes of the Patient that describe and identify the Patient who is the subject of a diagnostic Study. This Module contains Attributes of the patient that are needed for diagnostic interpretation of the Image and are common for all studies performed on the patient.

**TABLE 2.4-1
PATIENT MODULE ATTRIBUTES**

Attribute Name	Tag	Type	VR	VM	Discovery ST PET Attribute (Discovery ST PET Patient table unless otherwise specified)	Notes
Patient's Name	(0010,0010)	2	PN (64)	1	patient_name	
Patient ID	(0010,0020)	2	LO (64)	1	patient_identifier	
Patient's Birth Date	(0010,0030)	2	DA (26)	1	birthdate	
Patient's Sex	(0010,0040)	2	CS (16)	1	sex	
Referenced Patient Sequence	(0008,1120)	3	SQ	1	Not Used	
>Referenced SOP Class UID	(0008,1150)	1C	UI	1	Not Used	
>Referenced SOP Instance UID	(0008,1155)	1C	UI	1	Not Used	
Patient's Birth Time	(0010,0032)	3	TM	1	Not Used	
Other Patient IDs	(0010,1000)	3	LO	1-n	Not Used	
Other Patient Names	(0010,1001)	3	PN	1-n	Not Used	
Ethnic Group	(0010,2160)	3	SH	1	Not Used	
Patient Comments	(0010,4000)	3	LT	1	Not Used	

D.5.1.2 GE Discovery ST PET Patient

Refer to Section D.6.2 for details.

D.5.2 Common Study Entity Modules

The following Study IE Modules are common to all Composite Image IODs which reference the Study IE. These Module contain Attributes of the patient and study that are needed for diagnostic interpretation of the image.

D.5.2.1 General Study Module

This section specifies the Attributes which describe and identify the Study performed upon the Patient.

**TABLE 2.4-2
GENERAL STUDY MODULE ATTRIBUTES**

Attribute Name	Tag	Type	VR	VM	Discovery ST PET Attribute (GE Discovery ST PET Exam table unless otherwise specified)	Notes
Study Instance UID	(0020,000D)	1	UI	1	study_uid	
Study Date	(0008,0020)	2	DA	1	extract date from exam_datetime	
Study Time	(0008,0030)	2	TM	1	extract time exam_datetime	
Referring Physician's Name	(0008,0090)	2	PN	1	ref_physician	
Study ID	(0020,0010)	2	SH	1	study_identifier	
Accession Number	(0008,0050)	2	SH	1	requisition	
Study Description	(0008,1030)	3	LO	1	exam_desc	
Physician(s) of Record	(0008,1048)	3	PN	1-n	Not Used	
Name of Physician(s) Reading Study	(0008,1060)	3	PN	1-n	diagnostician	
Referenced Study Sequence	(0008,1110)	3	SQ	1	Not Used	
> Referenced SOP Class UID	(0008,1150)	1C	UI	1	Not Used	
> Referenced SOP Instance UID	(0008,1155)	1C	UI	1	Not Used	

D.5.2.2 Patient Study Module

This section defines Attributes that provide information about the Patient at the time the Study was performed.

**TABLE 2.4-3
PATIENT STUDY MODULE ATTRIBUTES**

Attribute Name	Tag	Type	VR	VM	Discovery ST PET Attribute (GE Discovery ST PET Exam table unless otherwise specified)	Notes
----------------	-----	------	----	----	--	-------

Admitting Diagnosis Description	(0008,1080)	3	LO	1-n	Not Used	
Patient's Age	(0010,1010)	3	AS	1	truncate years from (Exam.exam_datetime - Patient.patient_birthdate)	
Patient's Size	(0010,1020)	3	DS	1	patient_ht / 100.0 (convert cm to m)	
Patient's Weight	(0010,1030)	3	DS	1	patient_wt	
Occupation	(0010,2180)	3	SH	1	Not Used	
Additional Patient's History	(0010,21B0)	3	LT	1	patient_history	

D.5.2.3 GE Discovery ST PET Exam Module

Refer to Section D.6.3 for details.

D.5.3 Common Series Entity Modules

The following Series IE Modules are common to all Composite Image IODs which reference the Series IE.

D.5.3.1 General Series Module

This section specifies the Attributes which identify and describe general information about the Series within a Study.

**TABLE 2.4-4
GENERAL SERIES MODULE ATTRIBUTES**

Attribute Name	Tag	Type	VR	VM	Discovery ST PET Attribute (GE Discovery ST PET ImageSet table unless otherwise specified)	Notes
Modality	(0008,0060)	1	CS	1	Imageset.modality	
Series Instance UID	(0020,000E)	1	UI	1	IF (SOP Class UID == "1.2.840.113619.4.30") THEN = Scan.scan_id ELSE = image_set_id	
Series Number	(0020,0011)	2	IS	1	series_number	
Laterality	(0020,0060)	2C	CS	1	Not Used	
Series Date	(0008,0021)	3	DA	1	superceded by PET Series.Series Date (0008,0021)	

Attribute Name	Tag	Type	VR	VM	Discovery ST PET Attribute (GE Discovery ST PET ImageSet table unless otherwise specified)	Notes
Series Time	(0008,0031)	3	TM	1	superceded by PET Series.Series Time (0008,0031)	
Performing Physician's Name	(0008,1050)	3	PN	1-n	Not Used	
Protocol Name	(0018,1030)	3	LO	1	Not Used	
Series Description	(0008,103E)	3	LO	1	IF (SOP Class UID == "1.2.840.113619.4.30") THEN = Scan.scan_description ELSE = is_description	
Operators' Name	(0008,1070)	3	PN	1-n	Exam.operator	
Referenced Study Component Sequence	(0008,1111)	3	SQ	1	Not Used	
> Referenced SOP Class UID	(0008,1150)	1C	UI	1	Not Used	
> Referenced SOP Instance UID	(0008,1155)	1C	UI	1	Not Used	
Body Part Examined	(0018,0015)	3	CS	1	Not Used	
Patient Position	(0018,5100)	2C	CS	1	Scan.patient_position, Frame.patient_entry	
Smallest Pixel Value in Series	(0028,0108)	3	US/SS	1	Not Used	
Largest Pixel Value in Series	(0028,0109)	3	US/SS	1	Not Used	

D.5.3.2 PET Series Module

TABLE 2.4-5
PET SERIES MODULE ATTRIBUTES

Attribute Name	Tag	Type	VR	VM	Discovery ST PET Attribute (GE Discovery ST PET ImageSet table unless otherwise specified)	Notes
Series Date	(0008,0021)	1	DA	1	extract date from Scan.scan_datetime	
Series Time	(0008,0031)	1	TM	1	extract time from Scan.scan_datetime	
Counts Source	(0054,1002)	1	CS	1	Scan.scan_type	

Attribute Name	Tag	Type	VR	VM	Discovery ST PET Attribute (GE Discovery ST PET ImageSet table unless otherwise specified)	Notes
Units	(0054,1001)	1	CS	1	units	
Series Type	(0054,1000)	1	CS	2	is_contents Scan.scan_mode	
Reprojection Method	(0054,1004)	2C	CS	1	is_contents	
Number of R-R Intervals	(0054,0061)	1C	US	1	IF (Scan.scan_mode == [gated]) THEN Count the unique image.image_bin_time for images with Image.image_set_id = thisSOPInstance.ImageSetID ELSE = NULL	
Number of Time Slots	(0054,0071)	1C	US	1	IF (Scan.scan_mode == [gated]) THEN = 1 ELSE = NULL	
Number of Time Slices	(0054,0101)	1C	US	1	Count the unique image.image_time for images with Image.image_set_id = thisSOPInstance.ImageSetID	
Number of Slices	(0054,0081)	1	US	1	Count the unique image.image_location for images with Image.image_set_id = thisSOPInstance.ImageSetID	
Corrected Image	(0028,0051)	2	CS	1-n	many	
Randoms Correction Method	(0054,1100)	3	CS	1	IF (Scan.scan_type = [emission]) THEN TR 14: emiss_randoms trans_randoms = NULL ELSE TR 14: trans_randoms emiss_randoms = NULL	
Attenuation Correction Method	(0054,1101)	3	LO	1	attenuation atten_coefficient atten_smooth	
Scatter Correction Method	(0054,1105)	3	LO	1	scatter	
Decay Correction	(0054,1102)	1	CS	1	decay	
Reconstruction Diameter	(0018,1100)	3	DS	1	bp_dfov * 10.0 (cm to mm)	
Convolution Kernel	(0018,1210)	3	SH	1-n	many	

Attribute Name	Tag	Type	VR	VM	Discovery ST PET Attribute (GE Discovery ST PET ImageSet table unless otherwise specified)	Notes
)					
Reconstruction Method	(0054,1103)	3	LO	1	recon_method	
Detector Lines of Response Used	(0054,1104)	3	LO	1	axial_angles_used	
Acquisition Start Condition	(0018,0073)	3	CS	1	Scan.start_condition	
Acquisition Start Condition Data	(0018,0074)	3	IS	1	Scan.start_cond_data	
Acquisition Termination Condition	(0018,0071)	3	CS	1	Scan.sel_stop_cond	
Acquisition Termination Condition Data	(0018,0075)	3	IS	1	Scan.sel_stop_cond_data	
Field of View Shape	(0018,1147)	3	CS	1	IF is_type == [native PET images] THEN = "CYLINDRICAL RING"	
Field of View Dimensions	(0018,1149)	3	IS	1-2	10.0*Scan.scan_fov \ Scan.axial_fov	
Gantry /Detector Tilt	(0018,1120)	3	DS	1	Scan.gantry_tilt_angle	
Gantry/Detector Slew	(0018,1121)	3	DS	1		
Type of Detector Motion	(0054,0202)	3	CS	1	IF is_type == [native PET images] THEN = "NONE"	
Collimator Type	(0018,1181)	2	CS	1	Scan.collimation	
Collimator/Grid Name	(0018,1180)	3	SH	1	Not Used	
Axial Acceptance	(0054,1200)	3	DS	1	Scan.axial_acceptance acceptance_flag axial_angle_3d	
Axial Mash	(0054,1201)	3	IS	2	Scan.axial_acceptance acceptance_flag	
Transverse Mash	(0054,1202)	3	IS	1	Scan.theta_compression	
Detector Element Size	(0054,1203)	3	DS	2	Not Used	
Coincidence Window Width	(0054,1210)	3	DS	1	Scan.upper_coinc_limit - Scan.lower_coinc_limit	
Energy Window Range Sequence	(0054,0013)	3	SQ	1		

Attribute Name	Tag	Type	VR	VM	Discovery ST PET Attribute (GE Discovery ST PET ImageSet table unless otherwise specified)	Notes
> Energy Window Lower Limit	(0054,0014)	3	DS	1	Scan.lower_energy_limit	
> Energy Window Upper Limit	(0054,0015)	3	DS	1	Scan.upper_energy_limit	
Secondary Counts Type	(0054,1220)	3	CS	1-n	IF (Scan.delayed_events == [separate]) THEN = "DLYD"	

D.5.3.3 PET Isotope Module

TABLE 2.4-6
PET ISOTOPE MODULE ATTRIBUTES

Attribute Name	Tag	Type	VR	VM	Discovery ST PET Attribute (GE Discovery ST PET Scan table unless otherwise specified)	Notes
Radiopharmaceutical Information Sequence	(0054,0016)	2	SQ	1	Single item sequence	
> Radionuclide Code Sequence	(0054,0300)	2	SQ	1	Single item sequence	
>> Code Value	(0008,0100)	1C	SH	1	Value is based on radionuclide_name	
>> Coding Scheme Designator	(0008,0102)	1C	SH	1	99SDM	
>> Code Meaning	(0008,0104)	3	LO	1	radionuclide_name	
> Radiopharmaceutical Route	(0018,1070)	3	LO	1	Not Used	
> Administration Route Code Sequence	(0054,0302)	3	SQ	1	Not Used	
>> Code Value	(0008,0100)	1C	SH	1	Not Used	
>> Coding Scheme Designator	(0008,0102)	1C	SH	1	Not Used	
>> Code Meaning	(0008,0104)	3	LO	1	Not Used	
> Radiopharmaceutical Volume	(0018,1071)	3	DS	1	pre_inj_volume	
> Radiopharmaceutical Start Time	(0018,1072)	3	TM	1	admin_datetime	
> Radiopharmaceutical Stop Time	(0018,1073)	3	TM	1	Not Used	

Attribute Name	Tag	Type	VR	VM	Discovery ST PET Attribute (GE Discovery ST PET Scan table unless otherwise specified)	Notes
> Radionuclide Total Dose	(0018,1074)	3	DS	1	tracer_activity, post_inj_activity, half_life, meas_datetime, admin_datetime, post_inj_datetime	
> Radionuclide Half Life	(0018,1075)	3	DS	1	half_life	
> Radionuclide Positron Fraction	(0018,1076)	3	DS	1	positron_fraction	
> Radiopharmaceutical Specific Activity	(0018,1077)	3	DS	1	Not Used	
> Radiopharmaceutical	(0018,0031)	3	LO	1	tracer_name	
> Radiopharmaceutical Code Sequence	(0054,0304)	3	SQ	1	Single item sequence	
>> Code Value	(0008,0100)	1C	SH	1	Value is based on tracer_name	
>> Coding Scheme Designator	(0008,0102)	1C	SH	1	99SDM	
>> Code Meaning	(0008,0104)	3	LO	1	tracer_name	
Intervention Drug Information Sequence	(0018,0026)	3	SQ	1	Not Used	
> Intervention Drug Name	(0018,0034)	3	LO	1	Not Used	
> Intervention Drug Code Sequence	(0018,0029)	3	SQ	1	Not Used	
>> Code Value	(0008,0100)	1C	SH	1	Not Used	
>> Coding Scheme Designator	(0008,0102)	1C	SH	1	Not Used	
>> Code Meaning	(0008,0104)	3	LO	1	Not Used	
> Intervention Drug Start Time	(0018,0035)	3	TM	1	Not Used	
> Intervention Drug Stop Time	(0018,0027)	3	TM	1	Not Used	
> Intervention Drug Dose	(0018,0028)	3	DS	1	Not Used	

D.5.3.4 PET Multi-gated Acquisition Module

TABLE 2.4-7

PET ISOTOPE MODULE ATTRIBUTES

Attribute Name	Tag	Type	VR	VM	Discovery ST PET Attribute (GE Discovery ST PET Scan table unless otherwise specified)	Notes
Beat Rejection Flag	(0018,1080)	2	CS	1	IF (trig_rej_method == [none]) THEN = "N" ELSE = "Y"	
Trigger Source or Type	(0018,1061)	3	LO	1	Not Used	
PVC Rejection	(0018,1085)	3	LO	1	trig_rej_method	
Skip Beats	(0018,1086)	3	IS	1	number_for_reject	
Heart Rate	(0018,1088)	3	IS	1	Not Used	
Framing Type	(0018,1064)	3	LO	1	binning_mode	

D.5.3.5 GE Discovery ST PET ImageSet Module

Refer to Section D.6.6 for details.

D.5.3.6 GE Discovery ST PET Scan Module

Refer to Section D.6.4 for details.

D.5.4 Common Equipment Entity Modules

The following Equipment IE Module is common to all Composite Image IODs which reference the Equipment IE.

D.5.4.1 General Equipment Module

This section specifies the Attributes which identify and describe the piece of equipment which produced a Series of Images.

**TABLE 2.4-8
GENERAL EQUIPMENT MODULE ATTRIBUTES**

Attribute Name	Tag	Type	VR	VM	Discovery ST PET Attribute (GE Discovery ST PET Exam table unless otherwise specified)	Notes
Manufacturer	(0008,0070)	2	LO	1	manufacturer	
Institution Name	(0008,0080)	3	LO	1	hospital_name	
Institution Address	(0008,008)	3	ST	1	Not Used	

	1)					
Station Name	(0008,1010)	3	SH	1	Not Used	
Institutional Department Name	(0008,1040)	3	LO	1	Not Used	
Manufacturer's Model Name	(0008,1090)	3	LO	1	scanner_desc	
Device Serial Number	(0018,1000)	3	LO	1	Not Used	
Software Versions	(0018,1020)	3	LO	1	Image.software_version Curve.software_version Frame.software_version	
Spatial Resolution	(0018,1050)	3	DS	1	Not Used	
Date of Last Calibration	(0018,1200)	3	DA	1-n	Not Used	
Time of Last Calibration	(0018,1201)	3	TM	1-n	Not Used	
Pixel Padding Value	(0028,0120)	3	US or SS	1	Not Used	

D.5.5 Common Curve Entity Modules

The following Image IE Modules are common to all Composite Image IODs which reference the Image IE.

D.5.5.1 Curve Identification Module

This section specifies the Attributes which identify and describe an curve within a particular series.

**TABLE 2.4-9
CURVE IDENTIFICATION MODULE ATTRIBUTES**

Attribute Name	Tag	Type	VR	VM	Discovery ST PET Attribute (GE Discovery ST PET Curve table unless otherwise specified)	Notes
Curve Number	(0020,0024)	2	IS	1	1	
Curve Date	(0008,0025)	3	DA	1	extract date from curve_datetime	
Curve Time	(0008,0035)	3	TM	1	extract time from curve_datetime	
Referenced Image Sequence	(0008,1140)	3	SQ	1	Not Used	
>Referenced SOP Class UID	(0008,1150)	1	UI	1		

Attribute Name	Tag	Type	VR	VM	Discovery ST PET Attribute (GE Discovery ST PET Curve table unless otherwise specified)	Notes
>Referenced SOP Instance UID	(0008,1155)	1	UI	1		
Referenced Overlay Sequence	(0008,1130)	3	SQ	1	Not Used	
>Referenced SOP Class UID	(0008,1150)	1	UI	1		
>Referenced SOP Instance UID	(0008,1155)	1	UI	1		
Referenced Curve Sequence	(0008,1145)	3	SQ	1	Not Used	
>Referenced SOP Class UID	(0008,1150)	1	UI	1		
>Referenced SOP Instance UID	(0008,1155)	1	UI	1		

D.5.5.2 Curve Module

This section specifies the Attributes which identify and describe an curve within a particular series.

**TABLE 2.4-10
CURVE MODULE ATTRIBUTES**

Attribute Name	Tag	Type	VR	VM	Discovery ST PET Attribute (GE Discovery ST PET Curve table unless otherwise specified)	Notes
Curve Dimensions	(50xx,0005)	1	US	1	use curve_type	
Number of Points	(50xx,0010)	1	US	1	curve_size / sizeof (curvePoint) /* struct curvePoint in idbBlobStructs.h */	
Type of Data	(50xx,0020)	1	CS	1	curve_type SYSRATE = system count rate SLICERATE = slice count rate BLDSMPL = blood samples	Refer Note Below
Data Value Representation	(50xx,0103)	1	US	1	0002H	
Curve Data	(50xx,3000)	1	OW/OB	1	curve_data	
Curve Description	(50xx,0022)	3	LO	1	curve_name	
Axis Units	(50xx,0030)	3	SH	1-n	Graph.x_axis_units \	Refer

Attribute Name	Tag	Type	VR	VM	Discovery ST PET Attribute (GE Discovery ST PET Curve table unless otherwise specified)	Notes
)				Graph.y_axis_units	Note below
Axis Labels	(50xx,0040)	3	SH	1-n	Graph.x_axis_label \ Graph.y_axis_label (truncate from 32A to 16A)	
Minimum Coordinate Value	(50xx,0104)	3	US	1-n	Not Used	
Maximum Coordinate Value	(50xx,0105)	3	US	1-n	Not Used	
Curve Range	(50xx,0106)	3	SH	1-n	Graph.x_axis_min \ Graph.x_axis_max \ Graph.y_axis_min \ Graph.y_axis_max	
Curve Data Descriptor	(50xx,0110)	1C	US	1-n	Not Used	
Coordinate Start Value	(50xx,0112)	1C	US	1	Not Used	
Coordinate Step Value	(50xx,0114)	1C	US	1	Not Used	
Curve Label	(50xx,2500)	3	LO	1	CurvePresentation.curve_label	
Referenced Overlay Sequence	(50xx,2600)	3	SQ	1	Not Used	
>Referenced SOP Class UID	(0008,1150)	1	UI	1	Not Used	
>Referenced SOP Instance UID	(0008,1155)	1	UI	1	Not Used	
>Referenced Overlay Group	(50xx,2610)	1	US	1	Not Used	

Note:

```

IF ( curve_type == [ blood sample ] ) THEN
  CASE x_axis_units OF :
    [ msec ], [ sec ] : break; /* MILS and SEC ok */
    [ min ] : Axis Units (50xx,0030) Value 1 = SEC
  DEFAULT: Reject send

  CASE y_axis_units OF :
    [ counts/sec ] :break; /* BQML and CPS ok */
  DEFAULT:Reject send

```

```

IF ( curve_type == [ rate ] ) THEN
  CASE x_axis_units OF :
    [ msec ], [ sec ] : break; /* MLS, SEC ok */
    [ min ] : Axis Units (50xx,0030) Value 1 = SEC
    DEFAULT: Reject send

  CASE y_axis_units OF :
    [ counts/sec ] : break; /* CPS ok */
    DEFAULT: Reject send

```

Note: *Cardiac Polar Maps are not supported as part of the PET Curve IOD.*

D.5.5.3 PET Curve Module

This section specifies the Attributes that describe the PET Curve Module.

**TABLE 2.4-11
PET CURVE MODULE ATTRIBUTES**

Attribute Name	Tag	Type	VR	VM	Discovery ST PET Attribute (GE Discovery ST PET Curve table unless otherwise specified)	Notes
Curve Dimensions	(50xx,0005)	1	US	1	2	
Type of Data	(50xx,0020)	1	CS	1	curve_type	
Curve Data	(50xx,3000)	1	OW/OB	1	curve_data	
Axis Units	(50xx,0030)	3	SH	1-n	Graph.x_axis_units \ Graph.y_axis_units	
Dead Time Correction Flag	(0054,1401)	1C	CS	1	IF (curve_type == [blood sample] THEN = deadtime	
Counts Included	(0054,1400)	2C	CS	1-n	IF (Axis Units (50xx,0030) contains CPS or CNTS) THEN ImageSet.scatter or ImageSet.emiss_randoms	
Processing Function	(0018,5020)	3	LO	1	Not Used	

Note: *Cardiac Polar Maps are not supported as part of the PET Curve IOD.*

D.5.5.4 GE Discovery ST PET Curve

Refer to Section D.6.7 for details.

D.5.5.5 GE Discovery ST PET Graph

Refer to Section D.6.8 for details.

D.5.5.6 GE Discovery ST PET Curve Presentation

Refer to Section D.6.9 for details.

D.5.6 General Modules

The SOP Common Module is mandatory for all DICOM IODs.

D.5.6.1 SOP Common Module

This section defines the Attributes which are required for proper functioning and identification of the associated SOP Instances. They do not specify any semantics about the Real-World Object represented by the IOD.

TABLE 2.4-12
SOP COMMON MODULE ATTRIBUTES

Attribute Name	Tag	Type	VR	VM	Discovery ST PET Attribute (GE Discovery ST PET Image table unless otherwise specified)	Notes
SOP Class UID	(0008,0016)	1	UI	1		TR ⁴⁸
SOP Instance UID	(0008,0018)	1	UI	1		TR ⁴⁹
Specific Character Set	(0008,0005)	1C	CS	1	= NULL	
Instance Creation Date	(0008,0012)	3	DA	1	current_date	
Instance Creation Time	(0008,0013)	3	TM	1	current_time	
Instance Creator UID	(0008,0014)	3	UI	1	= 1.2.840.113619.1.131.<dbcode>	

T⁴⁸Translate value as follows:

```

IF (PET Image Transfer) THEN
    SOP Class UID (08,16) = 1.2.840.10008.5.1.4.1.1.128
ELSE IF (Curve Transfer)
    CASE ( Curve.curve_type ) OF :
        [ blood sample ], [ rates ] :
            /* PET Curve */
            SOP Class UID (08,16) = 1.2.840.10008.5.1.4.1.1.129
            break;
        [ profile ], [ histogram ], [ volume activity curve ], [ foreign ] :
        [ area ], [ patlak ], [ tac midframe ], [ tac effective ] :
            /* Standalone Curve */
            SOP Class UID (08,16) = 1.2.840.10008.5.1.4.1.1.9
            break;
ELSE IF (Polar Map Transfer) THEN
    Reject Transfer;

```

⁴⁹Translate value as follows:

```

IF (SOP Class UID (08,16) == "1.2.840.10008.5.1.4.1.1.128") THEN /* PET Image */
    SOP Instance UID (08,18) = Image.image_id
ELSE IF (SOP Class UID (08,16) == "1.2.840.10008.5.1.4.1.1.129") THEN /* PET Curve */
    IF (Type of Data (50xx,0020) != "CPM") THEN

```

```
        /* Polar map */  
        Reject Transfer  
/*Standalone Curve */  
  
ELSE IF (SOP Class UID (08,16) == "1.2.840.10008.5.1.4.1.1.9") THEN  
    SOP Instance UID (08,18) = Curve.curve_id
```

D.6 Private data dictionary

D.6.1 Private Creator Identification Information

**TABLE 2.4-1
PRIVATE CREATOR IDENTIFICATION (GEMS_PETD_01)**

Attribute Name	Tag	Type	VR	VM	Discovery ST PET Type
Private Creator Data Element	(0009,0010)	1	SH	1	n/a
GE Discovery ST PET Implementation Version Name	(0009,1001)	3	LO	2	n/a

D.6.2 GE Discovery ST PET Patient Module

**TABLE 2.4-2
GE DISCOVERY ST PET PATIENT MODULE PRIVATE ELEMENTS
PRIVATE CREATOR IDENTIFICATION (GEMS_PETD_01)**

Attribute Name	Tag	Type	VR	VM	Discovery ST PET Type
GE Discovery ST PET Patient.patient_id	(0009,1002)	3	LO	1	20A
GE Discovery ST PET Patient.compatible_version	(0009,1003)	3	SH	1	5A
GE Discovery ST PET Patient.software_version	(0009,1004)	3	SH	1	5A
GE Discovery ST PET Patient.patient_datetime	(0009,1005)	3	DT	1	D
GE Discovery ST PET Patient.type	(0009,1006)	3	SL	1	L

D.6.3 GE Discovery ST PET Exam Module

**TABLE 2.4-3
GE DISCOVERY ST PET EXAM MODULE PRIVATE ELEMENTS
PRIVATE CREATOR IDENTIFICATION (GEMS_PETD_01)**

Attribute Name	Tag	Type	VR	VM	Discovery ST PET Type
GE Discovery ST PET Exam.exam_id	(0009,1007)	3	UI	1	64A
GE Discovery ST PET Exam.compatible_version	(0009,1008)	3	SH	1	5A
GE Discovery ST PET Exam.software_version	(0009,1009)	3	SH	1	5A

D.6.4 GE Discovery ST PET Scan Module

TABLE 2.4-4

GE DISCOVERY ST PET SCAN MODULE PRIVATE ELEMENTS
PRIVATE CREATOR IDENTIFICATION (GEMS_PETD_01)

Attribute Name	Tag	Type	VR	VM	Discovery ST PET Type
GE Discovery ST PET Scan.scan_id	(0009,100A)	3	UI	1	64A
GE Discovery ST PET Scan.compatible_version	(0009,100B)	3	SH	1	5A
GE Discovery ST PET Scan.software_version	(0009,100C)	3	SH	1	5A
GE Discovery ST PET Scan.scan_datetime	(0009,100D)	3	DT	1	D
GE Discovery ST PET Scan.scan_ready	(0009,100E)	3	DT	1	D
GE Discovery ST PET Scan.scan_description	(0009,100F)	3	UI	1	64A
GE Discovery ST PET Scan.hospital_name	(0009,1010)	3	LO	1	32A
GE Discovery ST PET Scan.scanner_desc	(0009,1011)	3	LO	1	32A
GE Discovery ST PET Scan.manufacturer	(0009,1012)	3	LO	1	64A
GE Discovery ST PET Scan.for_identifier	(0009,1013)	3	UI	1	64A
GE Discovery ST PET Scan.landmark_name	(0009,1014)	3	LO	1	64A
GE Discovery ST PET Scan.landmark_abbrev	(0009,1015)	3	SH	1	2A
GE Discovery ST PET Scan.patient_position	(0009,1016)	3	SL	1	L
GE Discovery ST PET Scan.scan_perspective	(0009,1017)	3	SL	1	L
GE Discovery ST PET Scan.scan_type	(0009,1018)	3	SL	1	L
GE Discovery ST PET Scan.scan_mode	(0009,1019)	3	SL	1	L
GE Discovery ST PET Scan.start_condition	(0009,101A)	3	SL	1	L
GE Discovery ST PET Scan.start_cond_data	(0009,101B)	3	SL	1	L
GE Discovery ST PET Scan.sel_stop_cond	(0009,101C)	3	SL	1	L
GE Discovery ST PET Scan.sel_stop_cond_data	(0009,101D)	3	SL	1	L
GE Discovery ST PET Scan.collect_deadtime	(0009,101E)	3	SL	1	L
GE Discovery ST PET Scan.collect_singles	(0009,101F)	3	SL	1	L

Attribute Name	Tag	Type	VR	VM	Discovery ST PET Type
GE Discovery ST PET Scan.collect_countrate	(0009,1020)	3	SL	1	L
GE Discovery ST PET Scan.countrate_period	(0009,1021)	3	SL	1	L
GE Discovery ST PET Scan.delayed_events	(0009,1022)	3	SL	1	L
GE Discovery ST PET Scan.delayed_bias	(0009,1023)	3	SL	1	L
GE Discovery ST PET Scan.word_size	(0009,1024)	3	SL	1	L
GE Discovery ST PET Scan.axial_acceptance	(0009,1025)	3	SL	1	L
GE Discovery ST PET Scan.axial_angle_3d	(0009,1026)	3	SL	1	L
GE Discovery ST PET Scan.theta_compression	(0009,1027)	3	SL	1	L
GE Discovery ST PET Scan.axial_compression	(0009,1028)	3	SL	1	L
GE Discovery ST PET Scan.gantry_tilt_angle	(0009,1029)	3	FL	1	F
GE Discovery ST PET Scan.collimation	(0009,102A)	3	SL	1	L
GE Discovery ST PET Scan.scan_fov	(0009,102B)	3	SL	1	L
GE Discovery ST PET Scan.axial_fov	(0009,102C)	3	SL	1	L
GE Discovery ST PET Scan.event_separation	(0009,102D)	3	SL	1	L
GE Discovery ST PET Scan.mask_width	(0009,102E)	3	SL	1	L
GE Discovery ST PET Scan.binning_mode	(0009,102F)	3	SL	1	L
GE Discovery ST PET Scan.trig_rej_method	(0009,1030)	3	SL	1	L
GE Discovery ST PET Scan.number_for_reject	(0009,1031)	3	SL	1	L
GE Discovery ST PET Scan.lower_reject_limit	(0009,1032)	3	SL	1	L
GE Discovery ST PET Scan.upper_reject_limit	(0009,1033)	3	SL	1	L
GE Discovery ST PET Scan.triggers_acquired	(0009,1034)	3	SL	1	L
GE Discovery ST PET Scan.triggers_rejected	(0009,1035)	3	SL	1	L
GE Discovery ST PET Scan.tracer_name	(0009,1036)	3	LO	1	40A
GE Discovery ST PET Scan.batch_description	(0009,1037)	3	LO	1	40A
GE Discovery ST PET Scan.tracer_activity	(0009,1038)	3	FL	1	F

Attribute Name	Tag	Type	VR	VM	Discovery ST PET Type
GE Discovery ST PET Scan.meas_datetime	(0009,1039)	3	DT	1	D
GE Discovery ST PET Scan.pre_inj_volume	(0009,103A)	3	FL	1	F
GE Discovery ST PET Scan.admin_datetime	(0009,103B)	3	DT	1	D
GE Discovery ST PET Scan.post_inj_activity	(0009,103C)	3	FL	1	F
GE Discovery ST PET Scan.post_inj_datetime	(0009,103D)	3	DT	1	D
GE Discovery ST PET Scan.radionuclide_name	(0009,103E)	3	SH	1	6A
GE Discovery ST PET Scan.half_life	(0009,103F)	3	FL	1	F
GE Discovery ST PET Scan.positron_fraction	(0009,1040)	3	FL	1	F
GE Discovery ST PET Scan.source1_holder	(0009,1041)	3	SL	1	L
GE Discovery ST PET Scan.source1_activity	(0009,1042)	3	FL	1	F
GE Discovery ST PET Scan.source1_meas_dt	(0009,1043)	3	DT	1	D
GE Discovery ST PET Scan.source1_radnuclide	(0009,1044)	3	SH	1	6A
GE Discovery ST PET Scan.source1_half_life	(0009,1045)	3	FL	1	F
GE Discovery ST PET Scan.source2_holder	(0009,1046)	3	SL	1	L
GE Discovery ST PET Scan.source2_activity	(0009,1047)	3	FL	1	F
GE Discovery ST PET Scan.source2_meas_dt	(0009,1048)	3	DT	1	D
GE Discovery ST PET Scan.source2_radnuclide	(0009,1049)	3	SH	1	6A
GE Discovery ST PET Scan.source2_half_life	(0009,104A)	3	FL	1	F
GE Discovery ST PET Scan.source_speed	(0009,104B)	3	SL	1	L
GE Discovery ST PET Scan.source_location	(0009,104C)	3	FL	1	F
GE Discovery ST PET Scan.emission_present	(0009,104D)	3	SL	1	L
GE Discovery ST PET Scan.lower_axial_acc	(0009,104E)	3	SL	1	L
GE Discovery ST PET Scan.upper_axial_acc	(0009,104F)	3	SL	1	L

Attribute Name	Tag	Type	VR	VM	Discovery ST PET Type
GE Discovery ST PET Scan.lower_coinc_limit	(0009,1050)	3	SL	1	L
GE Discovery ST PET Scan.upper_coinc_limit	(0009,1051)	3	SL	1	L
GE Discovery ST PET Scan.coinc_delay_offset	(0009,1052)	3	SL	1	L
GE Discovery ST PET Scan.coinc_output_mode	(0009,1053)	3	SL	1	L
GE Discovery ST PET Scan.upper_energy_limit	(0009,1054)	3	SL	1	L
GE Discovery ST PET Scan.lower_energy_limit	(0009,1055)	3	SL	1	L
GE Discovery ST PET Scan.normal_cal_id	(0009,1056)	3	UI	1	64A
GE Discovery ST PET Scan.normal_2d_cal_id	(0009,1057)	3	UI	1	64A
GE Discovery ST PET Scan.blank_cal_id	(0009,1058)	3	UI	1	64A
GE Discovery ST PET Scan.wc_cal_id	(0009,1059)	3	UI	1	64A
GE Discovery ST PET Scan.derived	(0009,105A)	3	SL	1	L
GE Discovery ST PET Scan.contrast_agent	(0009,105B)	3	LO	1	64A

D.6.5 GE Discovery ST PET Frame Module

TABLE 2.4-5

GE DISCOVERY ST PET FRAME MODULE PRIVATE ELEMENTS PRIVATE CREATOR IDENTIFICATION (GEMS_PETD_01)

Attribute Name	Tag	Type	VR	VM	Discovery ST PET Type
GE Discovery ST PET Frame.frame_id	(0009,105C)	3	UI	1	64A
GE Discovery ST PET Frame.scan_id	(0009,105D)	3	UI	1	64A
GE Discovery ST PET Frame.exam_id	(0009,105E)	3	UI	1	64A
GE Discovery ST PET Frame.patient_id	(0009,105F)	3	LO	1	20A
GE Discovery ST PET Frame.compatible_version	(0009,1060)	3	SH	1	5A
GE Discovery ST PET Frame.software_version	(0009,1061)	3	SH	1	5A
GE Discovery ST PET Frame.where_is_frame	(0009,1062)	3	ST	1	256A
GE Discovery ST PET Frame.frame_size	(0009,1063)	3	SL	1	L

GE Discovery ST PET Frame.file_exists	(0009,1064)	3	SL	1	L
GE Discovery ST PET Frame.patient_entry	(0009,1065)	3	SL	1	L
GE Discovery ST PET Frame.table_height	(0009,1066)	3	FL	1	F
GE Discovery ST PET Frame.table_z_position	(0009,1067)	3	FL	1	F
GE Discovery ST PET Frame.landmark_datetime	(0009,1068)	3	DT	1	D
GE Discovery ST PET Frame.slice_count	(0009,1069)	3	SL	1	L
GE Discovery ST PET Frame.start_location	(0009,106A)	3	FL	1	F
GE Discovery ST PET Frame.acq_delay	(0009,106B)	3	SL	1	L
GE Discovery ST PET Frame.acq_start	(0009,106C)	3	DT	1	D
GE Discovery ST PET Frame.acq_duration	(0009,106D)	3	SL	1	L
GE Discovery ST PET Frame.acq_bin_dur	(0009,106E)	3	SL	1	L
GE Discovery ST PET Frame.acq_bin_start	(0009,106F)	3	SL	1	L
GE Discovery ST PET Frame.actual_stop_cond	(0009,1070)	3	SL	1	L
GE Discovery ST PET Frame.total_prompts	(0009,1071)	3	FD	1	Db1
GE Discovery ST PET Frame.total_delays	(0009,1072)	3	FD	1	Db1
GE Discovery ST PET Frame.frame_valid	(0009,1073)	3	SL	1	L
GE Discovery ST PET Frame.validity_info	(0009,1074)	3	SL	1	L
GE Discovery ST PET Frame.archived	(0009,1075)	3	SL	1	L
GE Discovery ST PET Frame.compression	(0009,1076)	3	SL	1	L
GE Discovery ST PET Frame.uncompressed_size	(0009,1077)	3	SL	1	L
GE Discovery ST PET Frame.accum_bin_dur	(0009,1078)	3	SL	1	L

D.6.6 GE Discovery ST PET ImageSet Module

TABLE 2.4-6

GE DISCOVERY ST PET IMAGESET MODULE PRIVATE ELEMENTS
PRIVATE CREATOR IDENTIFICATION (GEMS_PETD_01)

Attribute Name	Tag	Type	VR	VM	Discovery ST PET Type
GE Discovery ST PET ImageSet.compatible_version	(0009,1079)	3	SH	1	5A
GE Discovery ST PET ImageSet.software_version	(0009,107A)	3	SH	1	5A
GE Discovery ST PET	(0009,107B)	3	DT	1	D

Attribute Name	Tag	Type	VR	VM	Discovery ST PET Type
ImageSet.is_datetime					
GE Discovery ST PET ImageSet.is_source	(0009,107C)	3	SL	1	L
GE Discovery ST PET ImageSet.is_contents	(0009,107D)	3	SL	1	L
GE Discovery ST PET ImageSet.is_type	(0009,107E)	3	SL	1	L
GE Discovery ST PET ImageSet.is_reference	(0009,107F)	3	FL	3	F
GE Discovery ST PET ImageSet.multi_patient	(0009,1080)	3	SL	1	L
GE Discovery ST PET ImageSet.number_of_normals	(0009,1081)	3	SL	1	L
GE Discovery ST PET ImageSet.color_map_id	(0009,1082)	3	UI	1	64A
GE Discovery ST PET ImageSet.window_level_type	(0009,1083)	3	SL	1	L
GE Discovery ST PET ImageSet.rotate	(0009,1084)	3	FL	1	F
GE Discovery ST PET ImageSet.flip	(0009,1085)	3	SL	1	L
GE Discovery ST PET ImageSet.zoom	(0009,1086)	3	FL	1	F
GE Discovery ST PET ImageSet.pan_x	(0009,1087)	3	SL	1	L
GE Discovery ST PET ImageSet.pan_y	(0009,1088)	3	SL	1	L
GE Discovery ST PET ImageSet.window_level_min	(0009,1089)	3	FL	1	F
GE Discovery ST PET ImageSet.window_level_max	(0009,108A)	3	FL	1	F
GE Discovery ST PET ImageSet.recon_method	(0009,108B)	3	SL	1	L
GE Discovery ST PET ImageSet.attenuation	(0009,108C)	3	SL	1	L
GE Discovery ST PET ImageSet atten_coefficient	(0009,108D)	3	FL	1	F
GE Discovery ST PET ImageSet.bp_filter	(0009,108E)	3	SL	1	L
GE Discovery ST PET ImageSet.bp_filter_cutoff	(0009,108F)	3	FL	1	F
GE Discovery ST PET ImageSet.bp_filter_order	(0009,1090)	3	SL	1	L
GE Discovery ST PET ImageSet.bp_center_l	(0009,1091)	3	FL	1	F
GE Discovery ST PET ImageSet.bp_center_p	(0009,1092)	3	FL	1	F
GE Discovery ST PET ImageSet.atten_smooth	(0009,1093)	3	SL	1	L

Attribute Name	Tag	Type	VR	VM	Discovery ST PET Type
GE Discovery ST PET ImageSet.atten_smooth_param	(0009,1094)	3	SL	1	L
GE Discovery ST PET ImageSet.angle_smooth_param	(0009,1095)	3	SL	1	L
GE Discovery ST PET ImageSet.wellcountercal_id	(0009,1096)	3	UI	1	64A
GE Discovery ST PET ImageSet.trans_scan_id	(0009,1097)	3	UI	1	64A
GE Discovery ST PET ImageSet.norm_cal_id	(0009,1098)	3	UI	1	64A
GE Discovery ST PET ImageSet.blnc_cal_id	(0009,1099)	3	UI	1	64A
GE Discovery ST PET ImageSet.cac_edge_threshold	(0009,109A)	3	FL	1	F
GE Discovery ST PET ImageSet.cac_skull_offset	(0009,109B)	3	FL	1	F
GE Discovery ST PET ImageSet.emiss_sub_id	(0009,109C)	3	UI	1	64A
GE Discovery ST PET ImageSet.radial_filter_3d	(0009,109D)	3	SL	1	L
GE Discovery ST PET ImageSet.radial_cutoff_3d	(0009,109E)	3	FL	1	F
GE Discovery ST PET ImageSet.axial_filter_3d	(0009,109F)	3	SL	1	L
GE Discovery ST PET ImageSet.axial_cutoff_3d	(0009,10A0)	3	FL	1	F
GE Discovery ST PET ImageSet.axial_start	(0009,10A1)	3	FL	1	F
GE Discovery ST PET ImageSet.axial_spacing	(0009,10A2)	3	FL	1	F
GE Discovery ST PET ImageSet.axial_angles_used	(0009,10A3)	3	SL	1	L
GE Discovery ST PET ImageSet.ir_num_iterations	(0009,10B2)	3	SL	1	F
GE Discovery ST PET ImageSet.ir_num_subsets	(0009,10B3)	3	SL	1	L
GE Discovery ST PET ImageSet.ir_recon_fov	(0009,10B4)	3	FL	1	F
GE Discovery ST PET ImageSet.ir_corr_model	(0009,10B5)	3	SL	1	L
GE Discovery ST PET ImageSet.ir_loop_filter	(0009,10B6)	3	SL	1	L

Attribute Name	Tag	Type	VR	VM	Discovery ST PET Type
GE Discovery ST PET ImageSet.ir_pre_filt_parm	(0009,10B7)	3	FL	1	F
GE Discovery ST PET ImageSet.ir_loop_filt_parm	(0009,10B8)	3	SL	1	L
GE Discovery ST PET ImageSet.response_filt_parm	(0009,10B9)	3	FL	1	F
GE Discovery ST PET ImageSet.post_filter	(0009,10BA)	3	SL	1	L
GE Discovery ST PET ImageSet.post_filt_parm	(0009,10BB)	3	FL	1	F
GE Discovery ST PET ImageSet.ir_regularize	(0009,10BC)	3	SL	1	L
GE Discovery ST PET ImageSet.regularize_parm	(0009,10BD)	3	FL	1	F
GE Discovery ST PET ImageSet.ac_bp_filter	(0009,10BE)	3	SL	1	L
GE Discovery ST PET ImageSet.ac_bp_filt_cut_off	(0009,10BF)	3	FL	1	F
GE Discovery ST PET ImageSet.ac_bp_filt_order	(0009,10C0)	3	SL	1	L
GE Discovery ST PET ImageSet.ac_img_smooth	(0009,10C1)	3	SL	1	L
GE Discovery ST PET ImageSet.ac_img_smooth_parm	(0009,10C2)	3	FL	1	F
GE Discovery ST PET ImageSet.scatter_method	(0009,10C3)	3	SL	1	L
GE Discovery ST PET ImageSet.scatter_num_iter	(0009,10C4)	3	SL	1	L
GE Discovery ST PET ImageSet.scatter_parm	(0009,10C5)	3	FL	1	F

D.6.7 GE Discovery ST PET Curve Module

TABLE 2.4-7

**GE DISCOVERY ST PET CURVE MODULE PRIVATE ELEMENTS
PRIVATE CREATOR IDENTIFICATION (GEMS_PETD_01)**

Attribute Name	Tag	Type	VR	VM	Discovery ST PET Type
Private Creator Data Element	(5001,0010)	1	SH	1	n/a
GE Discovery ST PET Curve.curve_id	(5001,1001)	3	UI	1	64A
GE Discovery ST PET Curve.compatible_version	(5001,1002)	3	SH	1	5A

GE Discovery ST PET Curve.software_version	(5001,1003)	3	SH	1	5A
GE Discovery ST PET Curve.statistics_type	(5001,1004)	3	SL	1	L
GE Discovery ST PET Curve.how_derived	(5001,1005)	3	LT	1	Bt
GE Discovery ST PET Curve.how_derived_size	(5001,1006)	3	SL	1	L
GE Discovery ST PET Curve.multi_patient	(5001,1007)	3	SL	1	L
GE Discovery ST PET Curve.deadtime	(5001,1008)	3	SL	1	L

D.6.8 GE Discovery ST PET Graph Module

TABLE 2.4-8

**GE DISCOVERY ST PET GRAPH MODULE PRIVATE ELEMENTS
PRIVATE CREATOR IDENTIFICATION (GEMS_PETD_01)**

Attribute Name	Tag	Type	VR	VM	Discovery ST PET Type
Private Creator Data Element	(5003,0010)	1	SH	1	n/a
GE Discovery ST PET Graph Sequence	(5003,1001)	3	SQ	1	n/a
> GE Discovery ST PET Graph.graph_id	(5003,1002)	3	UI	1	64A
> GE Discovery ST PET Graph.compatible_version	(5003,1003)	3	SH	1	5A
> GE Discovery ST PET Graph.software_version	(5003,1004)	3	SH	1	5A
> GE Discovery ST PET Graph.title	(5003,1005)	3	LO	1	32A
> GE Discovery ST PET Graph.graph_datetime	(5003,1006)	3	DT	1	D
> GE Discovery ST PET Graph.graph_description	(5003,1007)	3	ST	1	128A
> GE Discovery ST PET Graph.title_font_name	(5003,1008)	3	LO	1	32A
> GE Discovery ST PET Graph.title_font_size	(5003,1009)	3	SH	1	2A
> GE Discovery ST PET Graph.footer	(5003,100A)	3	LO	1	64A
> GE Discovery ST PET Graph.footer_font_size	(5003,100B)	3	SH	1	2A
> GE Discovery ST PET Graph.foreground_color	(5003,100C)	3	LO	1	20A
> GE Discovery ST PET Graph.background_color	(5003,100D)	3	LO	1	20A
> GE Discovery ST PET Graph.graph_border	(5003,100E)	3	SL	1	L
> GE Discovery ST PET Graph.graph_width	(5003,100F)	3	SL	1	L
> GE Discovery ST PET Graph.graph_height	(5003,1010)	3	SL	1	L
> GE Discovery ST PET Graph.grid	(5003,1011)	3	SL	1	L
> GE Discovery ST PET Graph.label_font_name	(5003,1012)	3	LO	1	32A
> GE Discovery ST PET Graph.label_font_size	(5003,1013)	3	SH	1	2A
> GE Discovery ST PET Graph.axes_color	(5003,1014)	3	LO	1	20A
> GE Discovery ST PET Graph.x_axis_label	(5003,1015)	3	LO	1	32A
> GE Discovery ST PET Graph.x_axis_units	(5003,1016)	3	SL	1	L
> GE Discovery ST PET Graph.x_major_tics	(5003,1017)	3	FL	1	F

> GE Discovery ST PET Graph.x_axis_min	(5003,1018)	3	FL	1	F
> GE Discovery ST PET Graph.x_axis_max	(5003,1019)	3	FL	1	F
> GE Discovery ST PET Graph.y_axis_label	(5003,101A)	3	LO	1	32A
> GE Discovery ST PET Graph.y_axis_units	(5003,101B)	3	SL	1	L
> GE Discovery ST PET Graph.y_major_tics	(5003,101C)	3	FL	1	F
> GE Discovery ST PET Graph.y_axis_min	(5003,101D)	3	FL	1	F
> GE Discovery ST PET Graph.y_axis_max	(5003,101E)	3	FL	1	F
> GE Discovery ST PET Graph.legend_font_name	(5003,101F)	3	LO	1	32A
> GE Discovery ST PET Graph.legend_font_size	(5003,1020)	3	SH	1	2A
> GE Discovery ST PET Graph.legend_location_x	(5003,1021)	3	SL	1	L
> GE Discovery ST PET Graph.legend_location_y	(5003,1022)	3	SL	1	L
> GE Discovery ST PET Graph.legend_width	(5003,1023)	3	SL	1	L
> GE Discovery ST PET Graph.legend_height	(5003,1024)	3	SL	1	L
> GE Discovery ST PET Graph.legend_border	(5003,1025)	3	SL	1	L
> GE Discovery ST PET Graph.multi_patient	(5003,1026)	3	SL	1	L

D.6.9 GE Discovery ST PET Curve Presentation Module

TABLE 2.4-9

**GE DISCOVERY ST PET CURVE PRESENTATION MODULE PRIVATE ELEMENTS
PRIVATE CREATOR IDENTIFICATION (GEMS_PETD_01)**

Attribute Name	Tag	Type	VR	VM	Discovery ST PET Type
Private Creator Data Element	(5005,0010)	1	SH	1	n/a
GE Discovery ST PET CurvePresentation Sequence	(5005,1001)	3	SQ	1	n/a
> GE Discovery ST PET CurvePresentation.curvepresent_id	(5005,1002)	3	UI	1	64A
> GE Discovery ST PET CurvePresentation.graph_id	(5005,1003)	3	UI	1	64A
> GE Discovery ST PET CurvePresentation.curve_id	(5005,1004)	3	UI	1	64A
> GE Discovery ST PET CurvePresentation.compatible_version	(5005,1005)	3	SH	1	5A
> GE Discovery ST PET CurvePresentation.software_version	(5005,1006)	3	SH	1	5A
> GE Discovery ST PET CurvePresentation.curve_label	(5005,1007)	3	LO	1	60A
> GE Discovery ST PET CurvePresentation.color	(5005,1008)	3	LO	1	20A
> GE Discovery ST PET CurvePresentation.line_type	(5005,1009)	3	SL	1	L

> GE Discovery ST PET CurvePresentation.line_width	(5005,100A)	3	SL	1	L
> GE Discovery ST PET CurvePresentation.point_symbol	(5005,100B)	3	SL	1	L
> GE Discovery ST PET CurvePresentation.point_symbol_dim	(5005,100C)	3	SL	1	L
> GE Discovery ST PET CurvePresentation.point_color	(5005,100D)	3	LO	1	20A

E PATIENT ROOT QUERY/RETRIEVE INFORMATION MODEL Definition

E.1 introduction

This section specifies the use of the DICOM Patient Root Query/Retrieve Model used to organize data and against which a Query/Retrieve will be performed. The contents of this section are:

E.2 - Patient Root Information Model Description

E.3 - Patient Root Information Model Entity-Relationship Model

E.4 - Patient Root Information Model Keys

E.2 Patient Root Information Model Description

The Patient Root Query/Retrieve Information Model is based upon a four level hierarchy:

- 1 Patient
- 2 Study
- 3 Series
- 4 Image

The patient level is the top level and contains Attributes associated with the Patient Information Entity (IE) of Image IODs. Patient IEs are modality independent.

The study level is below the patient level and contains Attributes associated with the Study IE of Image IODs. A study belongs to a single patient. A single patient may have multiple studies. Study IEs are modality independent.

The series level is below the study level and contains Attributes associated with the Series, Frame of Reference and Equipment IEs of Image IODs. A series belongs to a single study. A single study may have multiple series. Series IEs are modality dependent

The lowest level is the image level and contains Attributes associated with the Image IE of Image IODs. An image belongs to a single series. A single series may contain multiple images. Image IEs are modality dependent

Note: The GE Discovery ST PET AE TM supports the Patient Root Model as the DICOM Query SCP only.

E.3 Patient Root Information Model Entity-Relationship Model

The Entity-Relationship diagram for the Patient Root Information Model schema is shown in Illustration E.3-1. In this figure, the following diagrammatic convention is established to represent the information organization :

- each entity is represented by a rectangular box

- each relationship is represented by a diamond shaped box.
- the fact that a relationship exists between two entities is depicted by lines connecting the corresponding entity boxes to the relationship boxes.

The relationships are fully defined with the maximum number of possible entities in the relationship shown. In other words, the relationship between Series and Image can have up to n Images per Series, but the Patient to Study relationship has 1 Study for each Patient (a Patient can have more than one Study on the system, however each Study will contain all of the information pertaining to that Patient).

ILLUSTRATION E.3-1
PATIENT ROOT QUERY/RETRIEVE INFORMATION MODEL E/R DIAGRAM

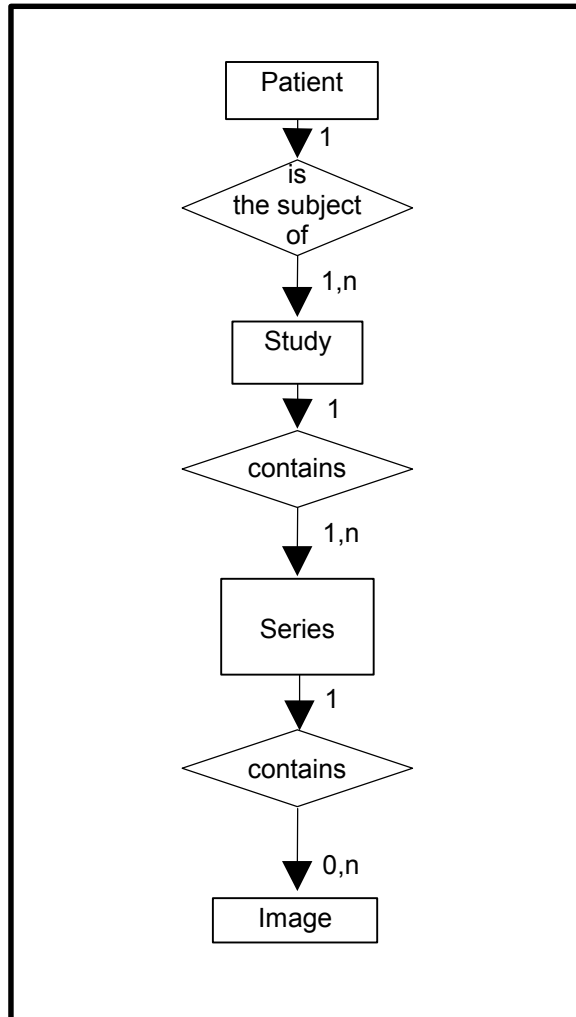

E.3.1 ENTITY DESCRIPTIONS

Please refer to DICOM Standard PS 3.4 (Service Class Specifications) for a description of each of the levels contained within the Patient Root Query/Retrieve Information Model.

E.3.1.1 Patient Entity Description

The Patient Entity defines the characteristics of a patient who is the subject of one or more medical studies which produce medical images.

E.3.1.2 Study Entity Description

The Study Entity defines the characteristics of a medical study performed on a patient. A study is a collection of one or more series of medical images which are logically related for the purpose of diagnosing a patient. Each study is associated with exactly one patient.

E.3.1.3 Series Entity Description

The Series Entity defines the attributes which are used to group images into distinct logical sets. Each series is associated with exactly one study.

E.3.1.4 Image Entity Description

The Image Entity defines the attributes which describe the pixel data of an image. The pixel data is generated as a direct result of patient scanning (an Original image). An image is defined by its image plane, pixel data characteristics gray scale and/or color mapping characteristics and modality specific characteristics (acquisition parameters and image creation information).

E.3.2 GE Discovery ST PET AE Mapping of DICOM entities

**TABLE 2.4-1
MAPPING OF DICOM ENTITIES TO DISCOVERY ST PET ENTITIES**

DICOM	Discovery ST PET Entity
Patient	Patient
Study	Exam
Series	ImageSet, Scan
Image	Image, Frame

E.4 INFORMATION Model Keys

Please refer to DICOM Standard PS 3.4 (Service Class Specifications) for a description of each of the levels contained within the Patient Root Query/Retrieve Information Model.

The following Level descriptions are included to specify what data elements are supported and what type of matching can be applied. It should be noted that they are the same ones as defined in the DICOM Standard PS 3.4 (Service Class Specifications).

E.4.1 Supported Matching

The GE Discovery ST PET AE Query SCP supports the following types of matching:

- Single Value matching
- List of UID matching
- Universal Matching
- Wild Card Matching
- Range of date, Range of Time

E.4.2 Patient Level

This section defines the keys at the Patient Level of the Patient Root Query/Retrieve Information Model that are supported by this implementation.

**TABLE E.4-1
PATIENT LEVEL ATTRIBUTES FOR THE PATIENT ROOT
QUERY/RETRIEVE INFORMATION MODEL**

Attribute Name	Tag	Type	Note
Patient's Name	(0010,0010)	R	Matched. Matching performed without regard to the PN VR individual component values.
Patient ID	(0010,0020)	U	Matched.
Patient's Sex	(0010,0040)	O	Returned

**TABLE E.4-2
Q/R PATIENT LEVEL AND LOCATION FOR RETRIEVE ATTRIBUTES**

Attribute Name	Tag	Type	Note
Query Retrieve Level	(0008,0052)	-	Value = PATIENT
Retrieve AE Title	(0008,0054)	-	AE Title of the local system (i.e. the system being queried)

E.4.3 Study Level

This section defines the keys at the Study Level of the Patient Root Query/Retrieve Information Model that are supported by this implementation.

**TABLE E.4-3
STUDY LEVEL ATTRIBUTES FOR THE PATIENT ROOT
QUERY/RETRIEVE INFORMATION MODEL**

Attribute Name	Tag	Type	Attribute Description
Study Date	(0008,0020)	R	Matched
Study Time	(0008,0030)	R	Matched
Accession Number	(0008,0050)	R	Matched based on exam.requisition
Modalities in Study	(0008,0061)	O	Matched
Study ID	(0020,0010)	R	Matched
Study Instance UID	(0020,000D)	U	Matched
Referring Physician's Name	(0008,0090)	O	Returned
Study Description	(0008,1030)	O	Returned
Name of Physician(s) Reading Study	(0008,1060)	O	Returned
Patient's Size	(0010,1020)	O	Returned
Patient's Weight	(0010,1030)	O	Returned
Number of Study Related Series	(0020,1206)	O	Returned

TABLE E.4-4

Q/R STUDY LEVEL AND LOCATION FOR RETRIEVE ATTRIBUTES

Attribute Name	Tag	Type	Note
Query Retrieve Level	(0008,0052)	-	Value = STUDY
Retrieve AE Title	(0008,0054)	-	AE Title of the local system (i.e. the system being queried)

E.4.4 Series Level

This section defines the keys at the Series Level of the Patient Root Query/Retrieve Information Model that are supported by this implementation.

**TABLE E.4-5
SERIES LEVEL ATTRIBUTES FOR THE PATIENT ROOT
QUERY/RETRIEVE INFORMATION MODEL**

Attribute Name	Tag	Type	Attribute Description
Modality	(0008,0060)	R	Matched
Series Number	(0020,0011)	R	Matched
Series Instance UID	(0020,000E)	U	Matched
Series Date	(0008,0021)	O	Returned
Series Time	(0008,0031)	O	Returned
Series Description	(0008,103E)	O	Returned
Operator's Name	(0008,1070)	O	Returned
Radio Pharmaceutical	(0008,1070)	O	Returned
Series Number of Images	(0020,1209)	O	Returned
Series Type	(0054,1000)	O	Returned
Counts Source	(0054,1002)	O	Returned
Imageset Source	(0009,107C)	O	Returned
Imageset Contents	(0009,107D)	O	Returned

**TABLE E.4-6
Q/R SERIES LEVEL AND LOCATION FOR RETRIEVE ATTRIBUTES**

Attribute Name	Tag	Type	Note
Query Retrieve Level	(0008,0052)	-	Value = SERIES
Retrieve AE Title	(0008,0054)	-	AE Title of the local system (i.e. the system being queried)

E.4.5 Image Level

This section defines the keys at the Image Level of the Patient Root Query/Retrieve Information Model that are supported by this implementation.

**TABLE E.4-7
IMAGE LEVEL ATTRIBUTES FOR THE PATIENT ROOT**

QUERY/RETRIEVE INFORMATION MODEL

Attribute Name	Tag	Type	Attribute Description
Image Number	(0020,0013)	R	Matched
SOP Instance UID	(0008,0018)	U	Matched
Rows	(0028,0010)	O	Returned
Columns	(0028,0011)	O	Returned

**TABLE E.4-8
Q/R IMAGE LEVEL AND LOCATION FOR RETRIEVE ATTRIBUTES**

Attribute Name	Tag	Type	Note
Query Retrieve Level	(0008,0052)	-	Value = IMAGE
Retrieve AE Title	(0008,0054)	-	AE Title of the local system (i.e. the system being queried)

E.4.6 Private data dictionary

The Type of a Private Attribute is determined by the level of the Information Model in which it is used, and hence is not listed in this dictionary.

**TABLE 2.44-9
PRIVATE CREATOR IDENTIFICATION (GEMS_PETD_01)**

SERIES LEVEL PRIVATE ATTRIBUTES FOR THE PATIENT ROOT MODEL

Attribute Name	Tag	VR	VM
Imageset Source	(0009,107C)	SL	1
Imageset Contents	(0009,107D)	SL	1

**F Study ROOT QUERY/RETRIEVE INFORMATION MODEL
Definition**

F.1 introduction

This section specifies the use of the DICOM Study Root Query/Retrieve Model used to organize data and against which a Query/Retrieve will be performed. The contents of this section are:

- F.2 - Study Root Information Model Description
- F.3 - Study Root Information Model Entity-Relationship Model
- F.4 - Study Root Information Model Keys

F.2 Study Root Information Model Description

The Study Root Query/Retrieve Information Model is based upon a three level hierarchy:

- Study

- Series
- Image

The study level is the top level and contains Attributes associated with the Study IE of Image IODs. Attributes of patients are considered to be attributes of studies. Study IEs are modality independent.

The series level is below the study level and contains Attributes associated with the Series, Frame of Reference and Equipment IEs of Image IODs. A series belongs to a single study. A single study may have multiple series. Series IEs are modality dependent

The lowest level is the image level and contains Attributes associated with the Image IE of Image IODs. An image belongs to a single series. A single series may contain multiple images. Image IEs are modality dependent

F.3 Study Root Information Model Entity-Relationship Model

The Entity-Relationship diagram for the Study Root Information Model schema is shown in Illustration F.3-1. In this figure, the following diagrammatic convention is established to represent the information organization :

- each entity is represented by a rectangular box
- each relationship is represented by a diamond shaped box.
- the fact that a relationship exists between two entities is depicted by lines connecting the corresponding entity boxes to the relationship boxes.

The relationships are fully defined with the maximum number of possible entities in the relationship shown. In other words, the relationship between Series and Image can have up to n Images per Series.

ILLUSTRATION F.3-1
STUDY ROOT QUERY/RETRIEVE INFORMATION MODEL E/R DIAGRAM

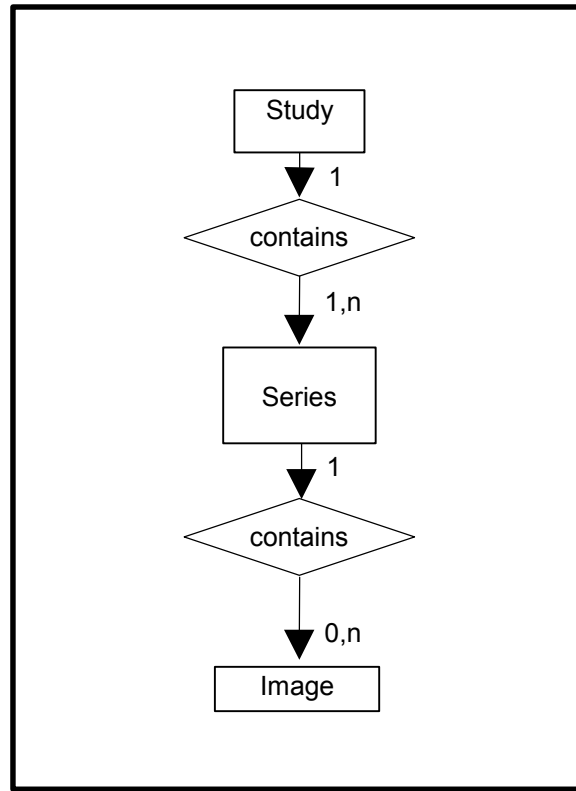

F.3.1 Entity Descriptions

Please refer to DICOM Standard PS 3.4 (Service Class Specifications) for a description of each of the levels contained within the Study Root Query/Retrieve Information Model.

F.3.1.1 Study Entity Description

The Study Entity defines the characteristics of a medical study performed on a patient. A study is a collection of one or more series of medical images which are logically related for the purpose of diagnosing a patient.

F.3.1.2 Series Entity Description

The Series Entity defines the attributes which are used to group images into distinct logical sets. Each series is associated with exactly one study.

F.3.1.3 Image Entity Description

The Image Entity defines the attributes which describe the pixel data of an image. The pixel data is generated as a direct result of patient scanning (an Original image). An image is defined by its image plane, pixel data characteristics gray scale and/or color mapping characteristics and modality specific characteristics (acquisition parameters and image creation information).

F.3.2 GE Discovery ST PET AE Mapping of DICOM entities

**TABLE 2.4-1
MAPPING OF DICOM ENTITIES TO DISCOVERY ST PET ENTITIES**

DICOM	Discovery ST PET Entity
Study	Exam
Series	Imageset, Scan
Image	Image, Frame

F.4 INFORMATION Model Keys

Please refer to DICOM Standard PS 3.4 (Service Class Specifications) for a description of each of the levels contained within the Study Root Query/Retrieve Information Model. The following Level descriptions are included to specify what data elements are supported and what type of matching can be applied. It should be noted that they are the same ones as defined in the DICOM Standard PS 3.4 (Service Class Specifications).

F.4.1 Supported Matching

The GE Discovery ST PET AE Query SCU request the following type(s) of matching:

- Wild Card Matching
- Single Value matching
- Range of date

The GE Discovery ST PET AE Query SCP supports the following types of matching:

- Single Value matching
- List of UID matching
- Universal Matching
- Wild Card Matching
- Range of date, Range of Time
- Sequence Matching

F.4.2 Study Level

This section defines the keys at the Study Level of the Study Root Query/Retrieve Information Model that are supported by this implementation.

**TABLE F.4-2
STUDY LEVEL ATTRIBUTES FOR THE STUDY ROOT
QUERY/RETRIEVE INFORMATION MODEL**

Attribute Name	Tag	Type	Note
Patient's Name	(0010,0010)	R	Matched. Matching performed without regard to the PN VR individual component values.
Patient ID	(0010,0020)	R	Matched.
Study Date	(0008,0020)	R	Matched
Study Time	(0008,0030)	R	Matched
Accession Number	(0008,0050)	R	Matched based on exam.requisition
Modalities in Study	(0008,0061)	O	Matched

Study ID	(0020,0010)	R	Matched
Study Instance UID	(0020,000D)	U	Matched
Referring Physician's Name	(0008,0090)	O	Returned
Study Description	(0008,1030)	O	Returned
Name of Physician(s) Reading Study	(0008,1060)	O	Returned
Patient's Size	(0010,1020)	O	Returned
Patient's Weight	(0010,1030)	O	Returned
Patient's Sex	(0010,0040)	O	Returned
Number of Study Related Series	(0020,1206)	O	Returned

TABLE F.4-3
Q/R STUDY LEVEL AND LOCATION FOR RETRIEVE ATTRIBUTES

Attribute Name	Tag	Type	Note
Query Retrieve Level	(0008,0052)	-	Value = STUDY
Retrieve AE Title	(0008,0054)	-	AE Title of the local system (i.e. the system being queried)

F.4.3 Series Level

This section defines the keys at the Series Level of the Study Root Query/Retrieve Information Model that are supported by this implementation.

TABLE F.4-4
SERIES LEVEL ATTRIBUTES FOR THE STUDY ROOT
QUERY/RETRIEVE INFORMATION MODEL

Attribute Name	Tag	Type	Attribute Description
Modality	(0008,0060)	R	Matched
Series Number	(0020,0011)	R	Matched
Series Instance UID	(0020,000E)	U	Matched
Series Date	(0008,0021)	O	Returned
Series Time	(0008,0031)	O	Returned
Series Description	(0008,103E)	O	Returned
Operator's Name	(0008,1070)	O	Returned
Radio Pharmaceutical	(0008,1070)	O	Returned
Series Number of Images	(0020,1209)	O	Returned
Series Type	(0054,1000)	O	Returned
Counts Source	(0054,1002)	O	Returned
Imageset Source	(0009,107C)	O	Returned
Imageset Contents	(0009,107D)	O	Returned

**TABLE F.4-5
Q/R SERIES LEVEL AND LOCATION FOR RETRIEVE ATTRIBUTES**

Attribute Name	Tag	Type	Note
Query Retrieve Level	(0008,0052)	-	Value = SERIES
Retrieve AE Title	(0008,0054)	-	AE Title of the local system (i.e. the system being queried)

F.4.4 Image Level

This section defines the keys at the Image Level of the Study Root Query/Retrieve Information Model that are supported by this implementation.

**TABLE F.4-6
IMAGE LEVEL ATTRIBUTES FOR THE STUDY ROOT
QUERY/RETRIEVE INFORMATION MODEL**

Attribute Name	Tag	Type	Attribute Description
Image Number	(0020,0013)	R	Matched
SOP Instance UID	(0008,0018)	U	Matched
Rows	(0028,0010)	O	Returned
Columns	(0028,0011)	O	Returned

**TABLE F.4-7
Q/R IMAGE LEVEL AND LOCATION FOR RETRIEVE ATTRIBUTES**

Attribute Name	Tag	Type	Note
Query Retrieve Level	(0008,0052)	-	Value = IMAGE
Retrieve AE Title	(0008,0054)	-	AE Title of the local system (i.e. the system being queried)

F.4.5 Private data dictionary

The Type of a Private Attribute is determined by the level of the Information Model in which it is used, and hence is not listed in this dictionary.

**TABLE 2.44-8
PRIVATE CREATOR IDENTIFICATION (GEMS_PETD_01)**

SERIES LEVEL PRIVATE ATTRIBUTES FOR THE STUDY ROOT MODEL

Attribute Name	Tag	VR	VM
Imageset Source	(0009,107C)	SL	1
Imageset Contents	(0009,107D)	SL	1

G Standalone curve INFORMATION OBJECT IMPLEMENTATION

G.1 introduction

This section specifies the use of the DICOM Standalone Curve IOD (referred to as the Curve IOD in other parts of this section) to represent the information included in curves produced by this implementation. Corresponding attributes are conveyed using the module construct. The contents of this section are:

G.2- Standalone Curve IOD Description

G.3- Standalone Curve IOD Entity-Relationship Model

G.4- Standalone Curve IOD Module Table

G.5- IOD Module Definition

G.2 STANDALONE CURVE IOD Implementation

The GE Discovery ST PET AE implementation of DICOM uses the Standalone Curve format when creating curve objects. The GE Discovery ST PET AE Curve object includes time activity curves, volume activity curves, image profile histograms, energy spectrum histograms and area curves. In order to preserve full fidelity when transferring data to a GE Discovery ST PET AE workstation, some specialized database information is encoded as private DICOM attributes. All of the Standard and private attributes used are defined in the module tables. The GE Discovery ST PET AE private data dictionary is included in Section G.6. Nevertheless, the GE Discovery ST PET AE is able to process DICOM curves without any private data elements.

G.3 STANDALONE CURVE Entity-Relationship Model

The Entity-Relationship diagram for the Curve interoperability schema is shown in **Illustration 7.3-1**. In this figure, the following diagrammatic convention is established to represent the information organization :

- each entity is represented by a rectangular box
- each relationship is represented by a diamond shaped box.
- the fact that a relationship exists between two entities is depicted by lines connecting the corresponding entity boxes to the relationship boxes.

The relationships are fully defined with the maximum number of possible entities in the relationship shown. In other words, the relationship between Series and Curve can have up to n Curves per Series, but the Patient to Study relationship has 1 Study for each Patient (a Patient can have more than one Study on the system, however each Study will contain all of the information pertaining to that Patient).

ILLUSTRATION 7.3-1
CURVE ENTITY RELATIONSHIP DIAGRAM

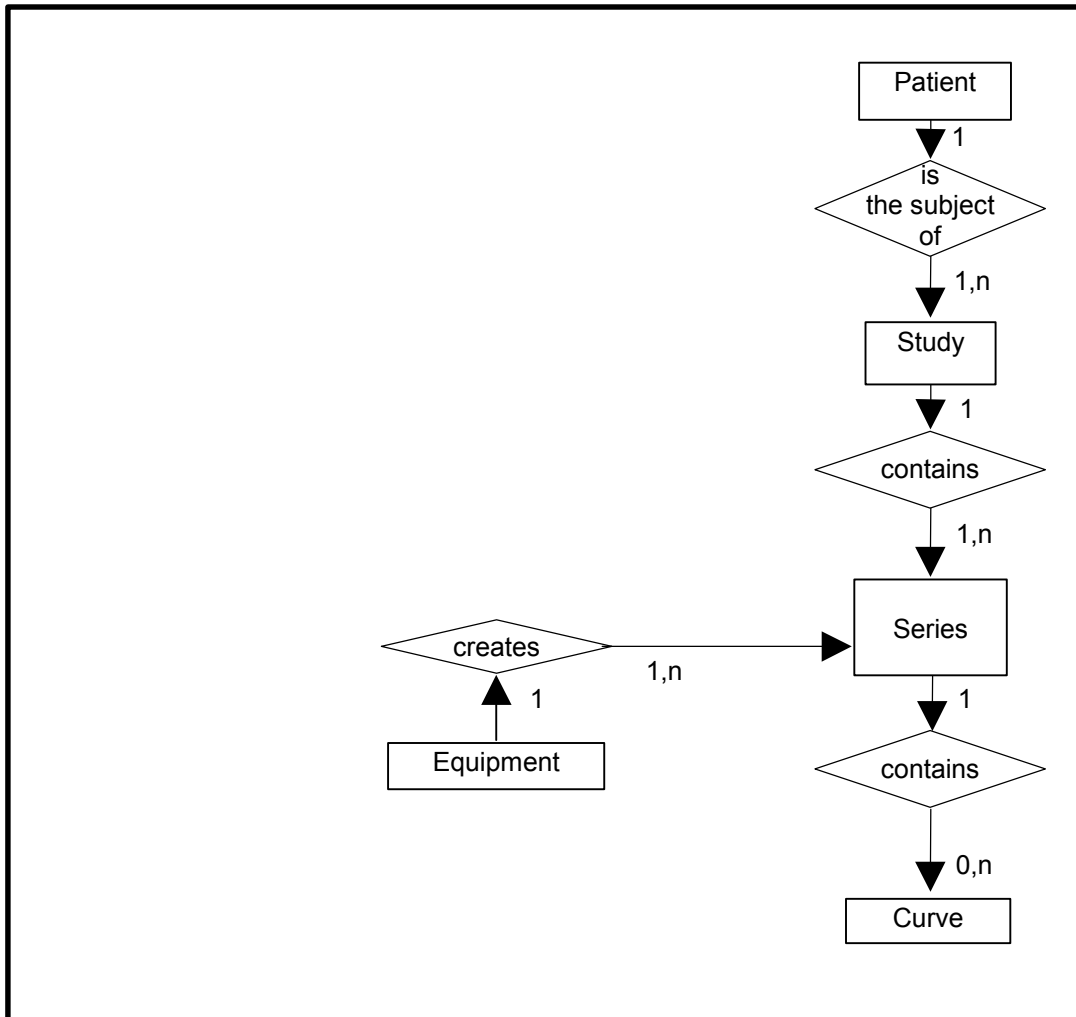

G.3.1 ENTITY DESCRIPTIONS

Please refer to DICOM Standard Part 3 (Information Object Definitions) for a description of each of the entities contained within the Information Object.

G.3.1.1 Patient Entity Description

The Patient Entity defines the characteristics of a patient who is the subject of one or more medical studies which produce medical images.

G.3.1.2 Study Entity Description

The Study Entity defines the characteristics of a medical study performed on a patient. A study is a collection of one or more series of medical images which are logically related for the purpose of diagnosing a patient. Each study is associated with exactly one patient.

G.3.1.3 Series Entity Description

The Series Entity defines the attributes which are used to group images into distinct logical sets. Each series is associated with exactly one study.

G.3.1.4 Equipment Entity Description

The Equipment Entity describes the particular imaging device which produced the series of images. An imaging device may produce one or more series within a study. The Equipment Entity does not describe the data acquisition or image creation Attributes used to generate images within a series.

G.3.1.5 Curve Entity Description

The Curve Entity defines the attributes which describe the curve data of a curve.

G.3.2 GE Discovery ST PET AE Mapping of DICOM entities

**TABLE 2.4-1
MAPPING OF DICOM ENTITIES TO DISCOVERY ST PET ENTITIES**

DICOM	<i>Discovery ST PET Entity</i>
Patient	Patient
Study	Exam
Series	Imageset
Curve	Curve, Graph, Curve Presentation

G.4 Standalone curve IOD MODULE TABLE

Within an entity of the DICOM IOD, attributes are grouped into related set of attributes. A set of related attributes is termed a module. A module facilitates the understanding of the semantics concerning the attributes and how the attributes are related with each other. A module grouping does not infer any encoding of information into datasets.

Table 2.4-1 identifies the defined modules within the entities which comprise the DICOM Standalone Curve IOD. Modules are identified by Module Name.

See DICOM Part 3 for a complete definition of the entities, modules, and attributes.

**TABLE 2.4-1
CURVE IOD MODULES**

Entity Name	Module Name	Reference
Patient	Patient	G.5.1.1
	GE Discovery ST PET Patient	G.5.1.2
Study	General Study	G.5.2.1
	Patient Study	G.5.2.2
	GE Discovery ST PET Exam	G.5.2.3
Series	General Series	G.5.3.1
	GE Discovery ST PET Imageset	G.5.3.2
	GE Discovery ST PET Scan	G.5.3.3
Equipment	General Equipment	G.5.4.1
Curve	Curve Identification	G.5.5.1
	Curve	G.5.5.2
	GE Discovery ST PET Curve	G.5.5.3
	GE Discovery ST PET Graph	G.5.5.4
	GE Discovery ST PET Curve Presentation	G.5.5.5
General Modules	SOP Common	G.5.6.1

G.5 STANDALONE CURVE INFORMATION MODULE DEFINITIONS

Please refer to DICOM Standard Part 3 (Information Object Definitions) for a description of each of the entities and modules contained within the Standalone Curve Information Object.

The following modules are included to convey Enumerated Values, Defined Terms, and Optional Attributes supported. Type 1 & Type 2 Attributes are also included for completeness and to define what values they may take and where these values are obtained from. It should be noted that they are the same ones as defined in the DICOM Standard Part 3 (Information Object Definitions).

G.5.1 Common Patient Entity Modules

G.5.1.1 Patient Module

This section specifies the Attributes of the Patient that describe and identify the Patient who is the subject of a diagnostic Study. This Module contains Attributes of the patient that are needed for diagnostic interpretation of the Image and are common for all studies performed on the patient.

**TABLE 2.4-1
PATIENT MODULE ATTRIBUTES**

Attribute Name	Tag	Type	VR	VM	Discovery ST PET Attribute (Discovery ST PET Patient table)	Notes
----------------	-----	------	----	----	--	-------

					unless otherwise specified)	
Patient's Name	(0010,0010)	2	PN (64)	1	patient_name	
Patient ID	(0010,0020)	2	LO (64)	1	patient_identifier	
Patient's Birth Date	(0010,0030)	2	DA (26)	1	birthdate	
Patient's Sex	(0010,0040)	2	CS (16)	1	sex	
Referenced Patient Sequence	(0008,1120)	3	SQ	1	Not Used	
>Referenced SOP Class UID	(0008,1150)	1C	UI	1	Not Used	
>Referenced SOP Instance UID	(0008,1155)	1C	UI	1	Not Used	
Patient's Birth Time	(0010,0032)	3	TM	1	Not Used	
Other Patient IDs	(0010,1000)	3	LO	1-n	Not Used	
Other Patient Names	(0010,1001)	3	PN	1-n	Not Used	
Ethnic Group	(0010,2160)	3	SH	1	Not Used	
Patient Comments	(0010,4000)	3	LT	1	Not Used	

G.5.1.2 GE Discovery ST PET Patient

Refer to Section G.6.2 for details.

G.5.2 Common Study Entity Modules

The following Study IE Modules are common to all Composite Image IODs which reference the Study IE. These Module contain Attributes of the patient and study that are needed for diagnostic interpretation of the image.

G.5.2.1 General Study Module

This section specifies the Attributes which describe and identify the Study performed upon the Patient.

**TABLE 2.4-2
GENERAL STUDY MODULE ATTRIBUTES**

Attribute Name	Tag	Type	VR	VM	Discovery ST PET Attribute (GE Discovery ST PET Exam table unless otherwise specified)	Notes
Study Instance UID	(0020,000D)	1	UI	1	study_uid	
Study Date	(0008,0020)	2	DA	1	extract date from exam_datetime	
Study Time	(0008,0030)	2	TM	1	extract time exam_datetime	
Referring Physician's Name	(0008,0090)	2	PN	1	ref_physician	
Study ID	(0020,0010)	2	SH	1	study_identifier	
Accession Number	(0008,0050)	2	SH	1	requisition	
Study Description	(0008,1030)	3	LO	1	exam_desc	
Physician(s) of Record	(0008,1048)	3	PN	1-n	Not Used	
Name of Physician(s) Reading Study	(0008,1060)	3	PN	1-n	diagnostician	
Referenced Study Sequence	(0008,1110)	3	SQ	1	Not Used	
> Referenced SOP Class UID	(0008,1150)	1C	UI	1	Not Used	
> Referenced SOP Instance UID	(0008,1155)	1C	UI	1	Not Used	

G.5.2.2 Patient Study Module

This section defines Attributes that provide information about the Patient at the time the Study was performed.

**TABLE 2.4-3
PATIENT STUDY MODULE ATTRIBUTES**

Attribute Name	Tag	Type	VR	VM	Discovery ST PET Attribute (GE Discovery ST PET Exam table unless otherwise specified)	Notes
----------------	-----	------	----	----	--	-------

Admitting Diagnosis Description	(0008,1080)	3	LO	1-n	Not Used	
Patient's Age	(0010,1010)	3	AS	1	truncate years from (Exam.exam_datetime - Patient.patient_birthdate)	
Patient's Size	(0010,1020)	3	DS	1	patient_ht / 100.0 (convert cm to m)	
Patient's Weight	(0010,1030)	3	DS	1	patient_wt	
Occupation	(0010,2180)	3	SH	1	Not Used	
Additional Patient's History	0010,21B0)	3	LT	1	patient_history	

G.5.2.3 GE Discovery ST PET Exam Module

Refer to Section G.6.3 for details.

G.5.3 Common Series Entity Modules

The following Series IE Modules are common to all Composite Image IODs which reference the Series IE.

G.5.3.1 General Series Module

This section specifies the Attributes which identify and describe general information about the Series within a Study.

**TABLE 2.4-4
GENERAL SERIES MODULE ATTRIBUTES**

Attribute Name	Tag	Type	VR	VM	Discovery ST PET Attribute (GE Discovery ST PET ImageSet table unless otherwise specified)	Notes
Modality	(0008,0060)	1	CS	1	imageset.modality	
Series Instance UID	(0020,000E)	1	UI	1	IF (SOP Class UID == "1.2.840.113619.4.30") THEN = Scan.scan_id ELSE = image_set_id	
Series Number	(0020,0011)	2	IS	1	series_number	
Laterality	(0020,0060)	2C	CS	1	Not Used	
Series Date	(0008,0021)	3	DA	1	extract date from imageset.datetime	

Series Time	(0008,0031)	3	TM	1	extract time from imageset.datetime	
Performing Physician's Name	(0008,1050)	3	PN	1-n	Not Used	
Protocol Name	(0018,1030)	3	LO	1	Not Used	
Series Description	(0008,103E)	3	LO	1	IF (SOP Class UID == "1.2.840.113619.4.30") THEN = Scan.scan_description ELSE = is_description	
Operators' Name	(0008,1070)	3	PN	1-n	Exam.operator	
Referenced Study Component Sequence	(0008,1111)	3	SQ	1	Not Used	
> Referenced SOP Class UID	(0008,1150)	1C	UI	1	Not Used	
> Referenced SOP Instance UID	(0008,1155)	1C	UI	1	Not Used	
Body Part Examined	(0018,0015)	3	CS	1	Not Used	
Patient Position	(0018,5100)	2C	CS	1	Scan.patient_position, Frame.patient_entry	
Smallest Pixel Value in Series	(0028,0108)	3	US/SS	1	Not Used	
Largest Pixel Value in Series	(0028,0109)	3	US/SS	1	Not Used	

G.5.3.2 GE Discovery ST PET ImageSet Module

Refer to Section G.6.5 for details.

G.5.3.3 GE Discovery ST PET Scan Module

Refer to Section G.6.4 for details.

G.5.4 Common Equipment Entity Modules

The following Equipment IE Module is common to all Composite Image IODs which reference the Equipment IE.

G.5.4.1 General Equipment Module

This section specifies the Attributes which identify and describe the piece of equipment which produced a Series of Images.

**TABLE 2.4-5
GENERAL EQUIPMENT MODULE ATTRIBUTES**

Attribute Name	Tag	Type	VR	VM	Discovery ST PET Attribute (GE Discovery ST PET Exam table unless otherwise specified)	Notes
Manufacturer	(0008,0070)	2	LO	1	manufacturer	
Institution Name	(0008,0080)	3	LO	1	hospital_name	
Institution Address	(0008,0081)	3	ST	1	Not Used	
Station Name	(0008,1010)	3	SH	1	Not Used	
Institutional Department Name	(0008,1040)	3	LO	1	Not Used	
Manufacturer's Model Name	(0008,1090)	3	LO	1	scanner_desc	
Device Serial Number	(0018,1000)	3	LO	1	Not Used	
Software Versions	(0018,1020)	3	LO	1	Image.software_version Curve.software_version Frame.software_version	
Spatial Resolution	(0018,1050)	3	DS	1	Not Used	
Date of Last Calibration	(0018,1200)	3	DA	1-n	Not Used	
Time of Last Calibration	(0018,1201)	3	TM	1-n	Not Used	
Pixel Padding Value	(0028,0120)	3	US or SS	1	Not Used	

G.5.5 Common Curve Entity Modules

The following Image IE Modules are common to all Composite Image IODs which reference the Image IE.

G.5.5.1 Curve Identification Module

This section specifies the Attributes which identify and describe an curve within a particular series.

**TABLE 2.4-6
CURVE IDENTIFICATION MODULE ATTRIBUTES**

Attribute Name	Tag	Type	VR	VM	Discovery ST PET Attribute (GE Discovery ST PET Curve table unless otherwise specified)	Notes
Curve Number	(0020,0024)	2	IS	1	1	
Curve Date	(0008,0025)	3	DA	1	extract date from curve_datetime	
Curve Time	(0008,0035)	3	TM	1	extract time from curve_datetime	
Referenced Image Sequence	(0008,1140)	3	SQ	1	Not Used	
>Referenced SOP Class UID	(0008,1150)	1	UI	1		
>Referenced SOP Instance UID	(0008,1155)	1	UI	1		
Referenced Overlay Sequence	(0008,1130)	3	SQ	1	Not Used	
>Referenced SOP Class UID	(0008,1150)	1	UI	1		
>Referenced SOP Instance UID	(0008,1155)	1	UI	1		
Referenced Curve Sequence	(0008,1145)	3	SQ	1	Not Used	
>Referenced SOP Class UID	(0008,1150)	1	UI	1		
>Referenced SOP Instance UID	(0008,1155)	1	UI	1		

G.5.5.2 Curve Module

This section specifies the Attributes which identify and describe an curve within a particular series.

**TABLE 2.4-7
CURVE MODULE ATTRIBUTES**

Attribute Name	Tag	Type	VR	VM	Discovery ST PET Attribute (GE Discovery ST PET Curve table unless otherwise specified)	Notes
Curve Dimensions	(50xx,0005)	1	US	1	use curve_type	
Number of Points	(50xx,0010)	1	US	1	curve_size / sizeof (curvePoint) /* struct curvePoint in idbBlobStructs.h */	
Type of Data	(50xx,0020)	1	CS	1	curve_type SYSRATE = system count rate SLICERATE = slice count rate BLDSMPL = blood samples	Refer Note Below
Data Value Representation	(50xx,0103)	1	US	1	0002H	
Curve Data	(50xx,3000)	1	OW/OB	1	curve_data	
Curve Description	(50xx,0022)	3	LO	1	curve_name	
Axis Units	(50xx,0030)	3	SH	1-n	Graph.x_axis_units \ Graph.y_axis_units	Refer Note below
Axis Labels	(50xx,0040)	3	SH	1-n	Graph.x_axis_label \ Graph.y_axis_label (truncate from 32A to 16A)	
Minimum Coordinate Value	(50xx,0104)	3	US	1-n	Not Used	
Maximum Coordinate Value	(50xx,0105)	3	US	1-n	Not Used	
Curve Range	(50xx,0106)	3	SH	1-n	Graph.x_axis_min \ Graph.x_axis_max \ Graph.y_axis_min \ Graph.y_axis_max	
Curve Data Descriptor	(50xx,0110)	1C	US	1-n	Not Used	
Coordinate Start Value	(50xx,0112)	1C	US	1	Not Used	
Coordinate Step Value	(50xx,0114)	1C	US	1	Not Used	
Curve Label	(50xx,2500)	3	LO	1	CurvePresentation.curve_label	

Referenced Overlay Sequence	(50xx,2600)	3	SQ	1	Not Used	
>Referenced SOP Class UID	(0008,1150)	1	UI	1	Not Used	
>Referenced SOP Instance UID	(0008,1155)	1	UI	1	Not Used	
>Referenced Overlay Group	(50xx,2610)	1	US	1	Not Used	

Note:

```
IF ( curve_type == [ blood sample ] ) THEN
  CASE x_axis_units OF :
    [ msec ], [ sec ] : break; /* MILS and SEC ok */
    [ min ] : Axis Units (50xx,0030) Value 1 = SEC
  DEFAULT: Reject send
```

```
  CASE y_axis_units OF :
    [ counts/sec] :break; /* BQML and CPS ok */
  DEFAULT:Reject send
```

```
IF ( curve_type == [ rate ] ) THEN
  CASE x_axis_units OF :
    [ msec ], [ sec ] : break; /* MLS, SEC ok */
    [ min ] : Axis Units (50xx,0030) Value 1 = SEC
  DEFAULT: Reject send
```

```
  CASE y_axis_units OF :
    [ counts/sec] : break; /* CPS ok */
  DEFAULT: Reject send
```

G.5.5.3 GE Discovery ST PET Curve

Refer to Section G.6.6 for details.

G.5.5.4 GE Discovery ST PET Graph

Refer to Section G.6.7 for details.

G.5.5.5 GE Discovery ST PET Curve Presentation

Refer to Section G.6.8 for details.

G.5.6 General Modules

The SOP Common Module is mandatory for all DICOM IODs.

G.5.6.1 SOP Common Module

This section defines the Attributes which are required for proper functioning and identification of the associated SOP Instances. They do not specify any semantics about the Real-World Object represented by the IOD.

**TABLE 2.4-8
SOP COMMON MODULE ATTRIBUTES**

Attribute Name	Tag	Type	VR	VM	Discovery ST PET Attribute (GE Discovery ST PET Image table unless otherwise specified)	Notes
SOP Class UID	(0008,0016)	1	UI	1		TR ⁴⁸
SOP Instance UID	(0008,0018)	1	UI	1		TR ⁴⁹
Specific Character Set	(0008,0005)	1C	CS	1	= NULL	
Instance Creation Date	(0008,0012)	3	DA	1	current_date	
Instance Creation Time	(0008,0013)	3	TM	1	current_time	
Instance Creator UID	(0008,0014)	3	UI	1	= 1.2.840.113619.1.131.<dbcode>	

T⁴⁸Translate value as follows:

```

IF (PET Image Transfer) THEN
    SOP Class UID (08,16) = 1.2.840.10008.5.1.4.1.1.128
ELSE IF (Curve Transfer)
    CASE ( Curve.curve_type ) OF :
        [ blood sample ], [ rates ] :
            /* PET Curve */
            SOP Class UID (08,16) = 1.2.840.10008.5.1.4.1.1.129
            break;
        [ profile ], [ histogram ], [ volume activity curve ], [ foreign ] :
        [ area ], [ patlak ], [ tac midframe ], [ tac effective ] :
            /* Standalone Curve */
            SOP Class UID (08,16) = 1.2.840.10008.5.1.4.1.1.9
            break;
ELSE IF (Polar Map Transfer) THEN
    Reject Transfer;
    
```

⁴⁹Translate value as follows:

```

IF (SOP Class UID (08,16) == "1.2.840.10008.5.1.4.1.1.128") THEN /* PET Image */
    SOP Instance UID (08,18) = Image.image_id
ELSE IF (SOP Class UID (08,16) == "1.2.840.10008.5.1.4.1.1.129") THEN /* PET Curve */
    IF (Type of Data (50xx,0020) != "CPM") THEN
    
```

```

/* Polar map */
Reject Transfer
/*Standalone Curve */

ELSE IF (SOP Class UID (08,16) == "1.2.840.10008.5.1.4.1.1.9") THEN
    SOP Instance UID (08,18) = Curve.curve_id
    
```

G.6 Private data dictionary

G.6.1 Private Creator Identification Information

TABLE 2.4-1
PRIVATE CREATOR IDENTIFICATION (GEMS_PETD_01)

Attribute Name	Tag	Type	VR	VM	Discovery ST PET Type
Private Creator Data Element	(0009,0010)	1	SH	1	n/a
GE Discovery ST PET Implementation Version Name	(0009,1001)	3	LO	2	n/a

G.6.2 GE Discovery ST PET Patient Module

TABLE 2.4-2
GE DISCOVERY ST PET PATIENT MODULE PRIVATE ELEMENTS
PRIVATE CREATOR IDENTIFICATION (GEMS_PETD_01)

Attribute Name	Tag	Type	VR	VM	Discovery ST PET Type
GE Discovery ST PET Patient.patient_id	(0009,1002)	3	LO	1	20A
GE Discovery ST PET Patient.compatible_version	(0009,1003)	3	SH	1	5A
GE Discovery ST PET Patient.software_version	(0009,1004)	3	SH	1	5A
GE Discovery ST PET Patient.patient_datetime	(0009,1005)	3	DT	1	D
GE Discovery ST PET Patient.type	(0009,1006)	3	SL	1	L

G.6.3 GE Discovery ST PET Exam Module

TABLE 2.4-3
GE DISCOVERY ST PET EXAM MODULE PRIVATE ELEMENTS
PRIVATE CREATOR IDENTIFICATION (GEMS_PETD_01)

Attribute Name	Tag	Type	VR	VM	Discovery ST
----------------	-----	------	----	----	--------------

					PET Type
GE Discovery ST PET Exam.exam_id	(0009,1007)	3	UI	1	64A
GE Discovery ST PET Exam.compatible_version	(0009,1008)	3	SH	1	5A
GE Discovery ST PET Exam.software_version	(0009,1009)	3	SH	1	5A

G.6.4 GE Discovery ST PET Scan Module

TABLE 2.4-4

**GE DISCOVERY ST PET SCAN MODULE PRIVATE ELEMENTS
PRIVATE CREATOR IDENTIFICATION (GEMS_PETD_01)**

Attribute Name	Tag	Type	VR	VM	Discovery ST PET Type
GE Discovery ST PET Scan.scan_id	(0009,100A)	3	UI	1	64A
GE Discovery ST PET Scan.compatible_version	(0009,100B)	3	SH	1	5A
GE Discovery ST PET Scan.software_version	(0009,100C)	3	SH	1	5A
GE Discovery ST PET Scan.scan_datetime	(0009,100D)	3	DT	1	D
GE Discovery ST PET Scan.scan_ready	(0009,100E)	3	DT	1	D
GE Discovery ST PET Scan.scan_description	(0009,100F)	3	UI	1	64A
GE Discovery ST PET Scan.hospital_name	(0009,1010)	3	LO	1	32A
GE Discovery ST PET Scan.scanner_desc	(0009,1011)	3	LO	1	32A
GE Discovery ST PET Scan.manufacturer	(0009,1012)	3	LO	1	64A
GE Discovery ST PET Scan.for_identifier	(0009,1013)	3	UI	1	64A
GE Discovery ST PET Scan.landmark_name	(0009,1014)	3	LO	1	64A
GE Discovery ST PET Scan.landmark_abbrev	(0009,1015)	3	SH	1	2A
GE Discovery ST PET Scan.patient_position	(0009,1016)	3	SL	1	L
GE Discovery ST PET Scan.scan_perspective	(0009,1017)	3	SL	1	L
GE Discovery ST PET Scan.scan_type	(0009,1018)	3	SL	1	L
GE Discovery ST PET Scan.scan_mode	(0009,1019)	3	SL	1	L
GE Discovery ST PET Scan.start_condition	(0009,101A)	3	SL	1	L
GE Discovery ST PET Scan.start_cond_data	(0009,101B)	3	SL	1	L

Attribute Name	Tag	Type	VR	VM	Discovery ST PET Type
GE Discovery ST PET Scan.sel_stop_cond	(0009,101C)	3	SL	1	L
GE Discovery ST PET Scan.sel_stop_cond_data	(0009,101D)	3	SL	1	L
GE Discovery ST PET Scan.collect_deadtime	(0009,101E)	3	SL	1	L
GE Discovery ST PET Scan.collect_singles	(0009,101F)	3	SL	1	L
GE Discovery ST PET Scan.collect_countrate	(0009,1020)	3	SL	1	L
GE Discovery ST PET Scan.countrate_period	(0009,1021)	3	SL	1	L
GE Discovery ST PET Scan.delayed_events	(0009,1022)	3	SL	1	L
GE Discovery ST PET Scan.delayed_bias	(0009,1023)	3	SL	1	L
GE Discovery ST PET Scan.word_size	(0009,1024)	3	SL	1	L
GE Discovery ST PET Scan.axial_acceptance	(0009,1025)	3	SL	1	L
GE Discovery ST PET Scan.axial_angle_3d	(0009,1026)	3	SL	1	L
GE Discovery ST PET Scan.theta_compression	(0009,1027)	3	SL	1	L
GE Discovery ST PET Scan.axial_compression	(0009,1028)	3	SL	1	L
GE Discovery ST PET Scan.gantry_tilt_angle	(0009,1029)	3	FL	1	F
GE Discovery ST PET Scan.collimation	(0009,102A)	3	SL	1	L
GE Discovery ST PET Scan.scan_fov	(0009,102B)	3	SL	1	L
GE Discovery ST PET Scan.axial_fov	(0009,102C)	3	SL	1	L
GE Discovery ST PET Scan.event_separation	(0009,102D)	3	SL	1	L
GE Discovery ST PET Scan.mask_width	(0009,102E)	3	SL	1	L
GE Discovery ST PET Scan.binning_mode	(0009,102F)	3	SL	1	L
GE Discovery ST PET Scan.trig_rej_method	(0009,1030)	3	SL	1	L
GE Discovery ST PET Scan.number_for_reject	(0009,1031)	3	SL	1	L
GE Discovery ST PET Scan.lower_reject_limit	(0009,1032)	3	SL	1	L
GE Discovery ST PET Scan.upper_reject_limit	(0009,1033)	3	SL	1	L
GE Discovery ST PET Scan.triggers_acquired	(0009,1034)	3	SL	1	L

Attribute Name	Tag	Type	VR	VM	Discovery ST PET Type
GE Discovery ST PET Scan.triggers_rejected	(0009,1035)	3	SL	1	L
GE Discovery ST PET Scan.tracer_name	(0009,1036)	3	LO	1	40A
GE Discovery ST PET Scan.batch_description	(0009,1037)	3	LO	1	40A
GE Discovery ST PET Scan.tracer_activity	(0009,1038)	3	FL	1	F
GE Discovery ST PET Scan.meas_datetime	(0009,1039)	3	DT	1	D
GE Discovery ST PET Scan.pre_inj_volume	(0009,103A)	3	FL	1	F
GE Discovery ST PET Scan.admin_datetime	(0009,103B)	3	DT	1	D
GE Discovery ST PET Scan.post_inj_activity	(0009,103C)	3	FL	1	F
GE Discovery ST PET Scan.post_inj_datetime	(0009,103D)	3	DT	1	D
GE Discovery ST PET Scan.radionuclide_name	(0009,103E)	3	SH	1	6A
GE Discovery ST PET Scan.half_life	(0009,103F)	3	FL	1	F
GE Discovery ST PET Scan.positron_fraction	(0009,1040)	3	FL	1	F
GE Discovery ST PET Scan.source1_holder	(0009,1041)	3	SL	1	L
GE Discovery ST PET Scan.source1_activity	(0009,1042)	3	FL	1	F
GE Discovery ST PET Scan.source1_meas_dt	(0009,1043)	3	DT	1	D
GE Discovery ST PET Scan.source1_radnuclide	(0009,1044)	3	SH	1	6A
GE Discovery ST PET Scan.source1_half_life	(0009,1045)	3	FL	1	F
GE Discovery ST PET Scan.source2_holder	(0009,1046)	3	SL	1	L
GE Discovery ST PET Scan.source2_activity	(0009,1047)	3	FL	1	F
GE Discovery ST PET Scan.source2_meas_dt	(0009,1048)	3	DT	1	D
GE Discovery ST PET Scan.source2_radnuclide	(0009,1049)	3	SH	1	6A
GE Discovery ST PET Scan.source2_half_life	(0009,104A)	3	FL	1	F
GE Discovery ST PET Scan.source_speed	(0009,104B)	3	SL	1	L
GE Discovery ST PET Scan.source_location	(0009,104C)	3	FL	1	F

Attribute Name	Tag	Type	VR	VM	Discovery ST PET Type
GE Discovery ST PET Scan.emission_present	(0009,104D)	3	SL	1	L
GE Discovery ST PET Scan.lower_axial_acc	(0009,104E)	3	SL	1	L
GE Discovery ST PET Scan.upper_axial_acc	(0009,104F)	3	SL	1	L
GE Discovery ST PET Scan.lower_coinc_limit	(0009,1050)	3	SL	1	L
GE Discovery ST PET Scan.upper_coinc_limit	(0009,1051)	3	SL	1	L
GE Discovery ST PET Scan.coinc_delay_offset	(0009,1052)	3	SL	1	L
GE Discovery ST PET Scan.coinc_output_mode	(0009,1053)	3	SL	1	L
GE Discovery ST PET Scan.upper_energy_limit	(0009,1054)	3	SL	1	L
GE Discovery ST PET Scan.lower_energy_limit	(0009,1055)	3	SL	1	L
GE Discovery ST PET Scan.normal_cal_id	(0009,1056)	3	UI	1	64A
GE Discovery ST PET Scan.normal_2d_cal_id	(0009,1057)	3	UI	1	64A
GE Discovery ST PET Scan.blank_cal_id	(0009,1058)	3	UI	1	64A
GE Discovery ST PET Scan.wc_cal_id	(0009,1059)	3	UI	1	64A
GE Discovery ST PET Scan.derived	(0009,105A)	3	SL	1	L
GE Discovery ST PET Scan.contrast_agent	(0009,105B)	3	LO	1	64A

G.6.5 GE Discovery ST PET ImageSet Module

TABLE 2.4-5

**GE DISCOVERY ST PET IMAGESET MODULE PRIVATE ELEMENTS
PRIVATE CREATOR IDENTIFICATION (GEMS_PETD_01)**

Attribute Name	Tag	Type	VR	VM	Discovery ST PET Type
GE Discovery ST PET ImageSet.compatible_version	(0009,1079)	3	SH	1	5A
GE Discovery ST PET ImageSet.software_version	(0009,107A)	3	SH	1	5A
GE Discovery ST PET	(0009,107B)	3	DT	1	D

Attribute Name	Tag	Type	VR	VM	Discovery ST PET Type
ImageSet.is_datetime					
GE Discovery ST PET ImageSet.is_source	(0009,107C)	3	SL	1	L
GE Discovery ST PET ImageSet.is_contents	(0009,107D)	3	SL	1	L
GE Discovery ST PET ImageSet.is_type	(0009,107E)	3	SL	1	L
GE Discovery ST PET ImageSet.is_reference	(0009,107F)	3	FL	3	F
GE Discovery ST PET ImageSet.multi_patient	(0009,1080)	3	SL	1	L
GE Discovery ST PET ImageSet.number_of_normals	(0009,1081)	3	SL	1	L
GE Discovery ST PET ImageSet.color_map_id	(0009,1082)	3	UI	1	64A
GE Discovery ST PET ImageSet.window_level_type	(0009,1083)	3	SL	1	L
GE Discovery ST PET ImageSet.rotate	(0009,1084)	3	FL	1	F
GE Discovery ST PET ImageSet.flip	(0009,1085)	3	SL	1	L
GE Discovery ST PET ImageSet.zoom	(0009,1086)	3	FL	1	F
GE Discovery ST PET ImageSet.pan_x	(0009,1087)	3	SL	1	L
GE Discovery ST PET ImageSet.pan_y	(0009,1088)	3	SL	1	L
GE Discovery ST PET ImageSet.window_level_min	(0009,1089)	3	FL	1	F
GE Discovery ST PET ImageSet.window_level_max	(0009,108A)	3	FL	1	F
GE Discovery ST PET ImageSet.recon_method	(0009,108B)	3	SL	1	L
GE Discovery ST PET ImageSet.attenuation	(0009,108C)	3	SL	1	L
GE Discovery ST PET ImageSet.atten_coefficient	(0009,108D)	3	FL	1	F
GE Discovery ST PET ImageSet.bp_filter	(0009,108E)	3	SL	1	L
GE Discovery ST PET ImageSet.bp_filter_cutoff	(0009,108F)	3	FL	1	F
GE Discovery ST PET ImageSet.bp_filter_order	(0009,1090)	3	SL	1	L
GE Discovery ST PET ImageSet.bp_center_l	(0009,1091)	3	FL	1	F
GE Discovery ST PET ImageSet.bp_center_p	(0009,1092)	3	FL	1	F
GE Discovery ST PET ImageSet.atten_smooth	(0009,1093)	3	SL	1	L

Attribute Name	Tag	Type	VR	VM	Discovery ST PET Type
GE Discovery ST PET ImageSet.atten_smooth_param	(0009,1094)	3	SL	1	L
GE Discovery ST PET ImageSet.angle_smooth_param	(0009,1095)	3	SL	1	L
GE Discovery ST PET ImageSet.wellcountercal_id	(0009,1096)	3	UI	1	64A
GE Discovery ST PET ImageSet.trans_scan_id	(0009,1097)	3	UI	1	64A
GE Discovery ST PET ImageSet.norm_cal_id	(0009,1098)	3	UI	1	64A
GE Discovery ST PET ImageSet.blk_cal_id	(0009,1099)	3	UI	1	64A
GE Discovery ST PET ImageSet.cac_edge_threshold	(0009,109A)	3	FL	1	F
GE Discovery ST PET ImageSet.cac_skull_offset	(0009,109B)	3	FL	1	F
GE Discovery ST PET ImageSet.emiss_sub_id	(0009,109C)	3	UI	1	64A
GE Discovery ST PET ImageSet.radial_filter_3d	(0009,109D)	3	SL	1	L
GE Discovery ST PET ImageSet.radial_cutoff_3d	(0009,109E)	3	FL	1	F
GE Discovery ST PET ImageSet.axial_filter_3d	(0009,109F)	3	SL	1	L
GE Discovery ST PET ImageSet.axial_cutoff_3d	(0009,10A0)	3	FL	1	F
GE Discovery ST PET ImageSet.axial_start	(0009,10A1)	3	FL	1	F
GE Discovery ST PET ImageSet.axial_spacing	(0009,10A2)	3	FL	1	F
GE Discovery ST PET ImageSet.axial_angles_used	(0009,10A3)	3	SL	1	L
GE Discovery ST PET ImageSet.ir_num_iterations	(0009,10B2)	3	SL	1	F
GE Discovery ST PET ImageSet.ir_num_subsets	09,10B4)	3	FL	1	F
GE Discovery ST PET ImageSet.ir_corr_model	(0009,10B5)	3	SL	1	L
GE Discovery ST PET ImageSet.ir_loop_filter	(0009,10B6)	3	SL	1	L
GE Discovery ST PET ImageSet.ir_pre_filt_parm	(0009,10B7)	3	FL	1	F

Attribute Name	Tag	Type	VR	VM	Discovery ST PET Type
GE Discovery ST PET ImageSet.ir_loop_filt_parm	(0009,10B8)	3	SL	1	L
GE Discovery ST PET ImageSet.response_filt_parm	(0009,10B9)	3	FL	1	F
GE Discovery ST PET ImageSet.post_filter	(0009,10BA)	3	SL	1	L
GE Discovery ST PET ImageSet.post_filt_parm	(0009,10BB)	3	FL	1	F
GE Discovery ST PET ImageSet.ir_regularize	(0009,10BC)	3	SL	1	L
GE Discovery ST PET ImageSet.regularize_parm	(0009,10BD)	3	FL	1	F
GE Discovery ST PET ImageSet.ac_bp_filter	(0009,10BE)	3	SL	1	L
GE Discovery ST PET ImageSet.ac_bp_filt_cut_off	(0009,10BF)	3	FL	1	F
GE Discovery ST PET ImageSet.ac_bp_filt_order	(0009,10C0)	3	SL	1	L
GE Discovery ST PET ImageSet.ac_img_smooth	(0009,10C1)	3	SL	1	L
GE Discovery ST PET ImageSet.ac_img_smooth_parm	(0009,10C2)	3	FL	1	F
GE Discovery ST PET ImageSet.scatter_method	(0009,10C3)	3	SL	1	L
GE Discovery ST PET ImageSet.scatter_num_iter	(0009,10C4)	3	SL	1	L
GE Discovery ST PET ImageSet.scatter_parm	(0009,10C5)	3	FL	1	F

G.6.6 GE Discovery ST PET Curve Module

TABLE 2.4-6

**GE DISCOVERY ST PET CURVE MODULE PRIVATE ELEMENTS
PRIVATE CREATOR IDENTIFICATION (GEMS_PETD_01)**

Attribute Name	Tag	Type	VR	VM	Discovery ST PET Type
Private Creator Data Element	(5001,0010)	1	SH	1	n/a
GE Discovery ST PET Curve.curve_id	(5001,1001)	3	UI	1	64A
GE Discovery ST PET Curve.compatible_version	(5001,1002)	3	SH	1	5A
GE Discovery ST PET Curve.software_version	(5001,1003)	3	SH	1	5A

Attribute Name	Tag	Type	VR	VM	Discovery ST PET Type
GE Discovery ST PET Curve.statistics_type	(5001,1004)	3	SL	1	L
GE Discovery ST PET Curve.how_derived	(5001,1005)	3	LT	1	Bt
GE Discovery ST PET Curve.how_derived_size	(5001,1006)	3	SL	1	L
GE Discovery ST PET Curve.multi_patient	(5001,1007)	3	SL	1	L
GE Discovery ST PET Curve.deadtime	(5001,1008)	3	SL	1	L

G.6.7 GE Discovery ST PET Graph Module

TABLE 2.4-7

**GE DISCOVERY ST PET GRAPH MODULE PRIVATE ELEMENTS
PRIVATE CREATOR IDENTIFICATION (GEMS_PETD_01)**

Attribute Name	Tag	Type	VR	VM	Discovery ST PET Type
Private Creator Data Element	(5003,0010)	1	SH	1	n/a
GE Discovery ST PET Graph Sequence	(5003,1001)	3	SQ	1	n/a
> GE Discovery ST PET Graph.graph_id	(5003,1002)	3	UI	1	64A
> GE Discovery ST PET Graph.compatible_version	(5003,1003)	3	SH	1	5A
> GE Discovery ST PET Graph.software_version	(5003,1004)	3	SH	1	5A
> GE Discovery ST PET Graph.title	(5003,1005)	3	LO	1	32A
> GE Discovery ST PET Graph.graph_datetime	(5003,1006)	3	DT	1	D
> GE Discovery ST PET Graph.graph_description	(5003,1007)	3	ST	1	128A
> GE Discovery ST PET Graph.title_font_name	(5003,1008)	3	LO	1	32A
> GE Discovery ST PET Graph.title_font_size	(5003,1009)	3	SH	1	2A
> GE Discovery ST PET Graph.footer	(5003,100A)	3	LO	1	64A
> GE Discovery ST PET Graph.footer_font_size	(5003,100B)	3	SH	1	2A
> GE Discovery ST PET Graph.foreground_color	(5003,100C)	3	LO	1	20A
> GE Discovery ST PET Graph.background_color	(5003,100D)	3	LO	1	20A
> GE Discovery ST PET Graph.graph_border	(5003,100E)	3	SL	1	L
> GE Discovery ST PET Graph.graph_width	(5003,100F)	3	SL	1	L
> GE Discovery ST PET Graph.graph_height	(5003,1010)	3	SL	1	L
> GE Discovery ST PET Graph.grid	(5003,1011)	3	SL	1	L
> GE Discovery ST PET Graph.label_font_name	(5003,1012)	3	LO	1	32A
> GE Discovery ST PET Graph.label_font_size	(5003,1013)	3	SH	1	2A
> GE Discovery ST PET Graph.axes_color	(5003,1014)	3	LO	1	20A
> GE Discovery ST PET Graph.x_axis_label	(5003,1015)	3	LO	1	32A

Attribute Name	Tag	Type	VR	VM	Discovery ST PET Type
> GE Discovery ST PET Graph.x_axis_units	(5003,1016)	3	SL	1	L
> GE Discovery ST PET Graph.x_major_tics	(5003,1017)	3	FL	1	F
> GE Discovery ST PET Graph.x_axis_min	(5003,1018)	3	FL	1	F
> GE Discovery ST PET Graph.x_axis_max	(5003,1019)	3	FL	1	F
> GE Discovery ST PET Graph.y_axis_label	(5003,101A)	3	LO	1	32A
> GE Discovery ST PET Graph.y_axis_units	(5003,101B)	3	SL	1	L
> GE Discovery ST PET Graph.y_major_tics	(5003,101C)	3	FL	1	F
> GE Discovery ST PET Graph.y_axis_min	(5003,101D)	3	FL	1	F
> GE Discovery ST PET Graph.y_axis_max	(5003,101E)	3	FL	1	F
> GE Discovery ST PET Graph.legend_font_name	(5003,101F)	3	LO	1	32A
> GE Discovery ST PET Graph.legend_font_size	(5003,1020)	3	SH	1	2A
> GE Discovery ST PET Graph.legend_location_x	(5003,1021)	3	SL	1	L
> GE Discovery ST PET Graph.legend_location_y	(5003,1022)	3	SL	1	L
> GE Discovery ST PET Graph.legend_width	(5003,1023)	3	SL	1	L
> GE Discovery ST PET Graph.legend_height	(5003,1024)	3	SL	1	L
> GE Discovery ST PET Graph.legend_border	(5003,1025)	3	SL	1	L
> GE Discovery ST PET Graph.multi_patient	(5003,1026)	3	SL	1	L

G.6.8 GE Discovery ST PET Curve Presentation Module

TABLE 2.4-8

GE DISCOVERY ST PET CURVE PRESENTATION MODULE PRIVATE ELEMENTS PRIVATE CREATOR IDENTIFICATION (GEMS_PETD_01)

Attribute Name	Tag	Type	VR	VM	Discovery ST PET Type
Private Creator Data Element	(5005,0010)	1	SH	1	n/a
GE Discovery ST PET CurvePresentation Sequence	(5005,1001)	3	SQ	1	n/a
> GE Discovery ST PET CurvePresentation.curvepresent_id	(5005,1002)	3	UI	1	64A
> GE Discovery ST PET CurvePresentation.graph_id	(5005,1003)	3	UI	1	64A
> GE Discovery ST PET CurvePresentation.curve_id	(5005,1004)	3	UI	1	64A
> GE Discovery ST PET CurvePresentation.compatible_version	(5005,1005)	3	SH	1	5A
> GE Discovery ST PET	(5005,1006)	3	SH	1	5A

CurvePresentation.software_version					
> GE Discovery ST PET CurvePresentation.curve_label	(5005,1007)	3	LO	1	60A
> GE Discovery ST PET CurvePresentation.color	(5005,1008)	3	LO	1	20A
> GE Discovery ST PET CurvePresentation.line_type	(5005,1009)	3	SL	1	L
> GE Discovery ST PET CurvePresentation.line_width	(5005,100A)	3	SL	1	L
> GE Discovery ST PET CurvePresentation.point_symbol	(5005,100B)	3	SL	1	L
> GE Discovery ST PET CurvePresentation.point_symbol_dim	(5005,100C)	3	SL	1	L
> GE Discovery ST PET CurvePresentation.point_color	(5005,100D)	3	LO	1	20A

H GE Private PET Raw Data INFORMATION OBJECT IMPLEMENTATION

H.1 introduction

This section specifies the implementation of GE private defined Information Object nsamey 'GE Private PET Raw data IOD'. The implementation is detailed to the extend that vendor applications can recognize an instance of the object.

Storage devices that supports full fidelity storage of this IOD can use the data detailed here to optimize the storage and retrieval of the data or display useful information to the user to distinguish among the IOD instances.

The IOD contains data that are not published in this document. No implementation shall assume any meaning to such data and its meaning and definition is subject to change without notice.

H.2 GE PRIVATE PET RAW DATA IOD Entity-Relationship Model

The Entity-Relationship diagram for the Ge Private PET Raw data is shown in **Illustration 7.3-1** . In this figure, the following diagrammatic convention is established to represent the information organization :

- each entity is represented by a rectangular box
- each relationship is represented by a diamond shaped box.
- the fact that a relationship exists between two entities is depicted by lines connecting the corresponding entity boxes to the relationship boxes.

The relationships are fully defined with the maximum number of possible entities in the relationship shown. In other words, the relationship between Series and Raw Data IOD can have up to n Instances per Series, but the Patient to Study relationship has 1 Study for each Patient (a Patient can have more than one Study on the system, however each Study will contain all of the information pertaining to that Patient).

ILLUSTRATION H-1
GE PRIVATE PET RAW DATA ENTITY RELATIONSHIP DIAGRAM

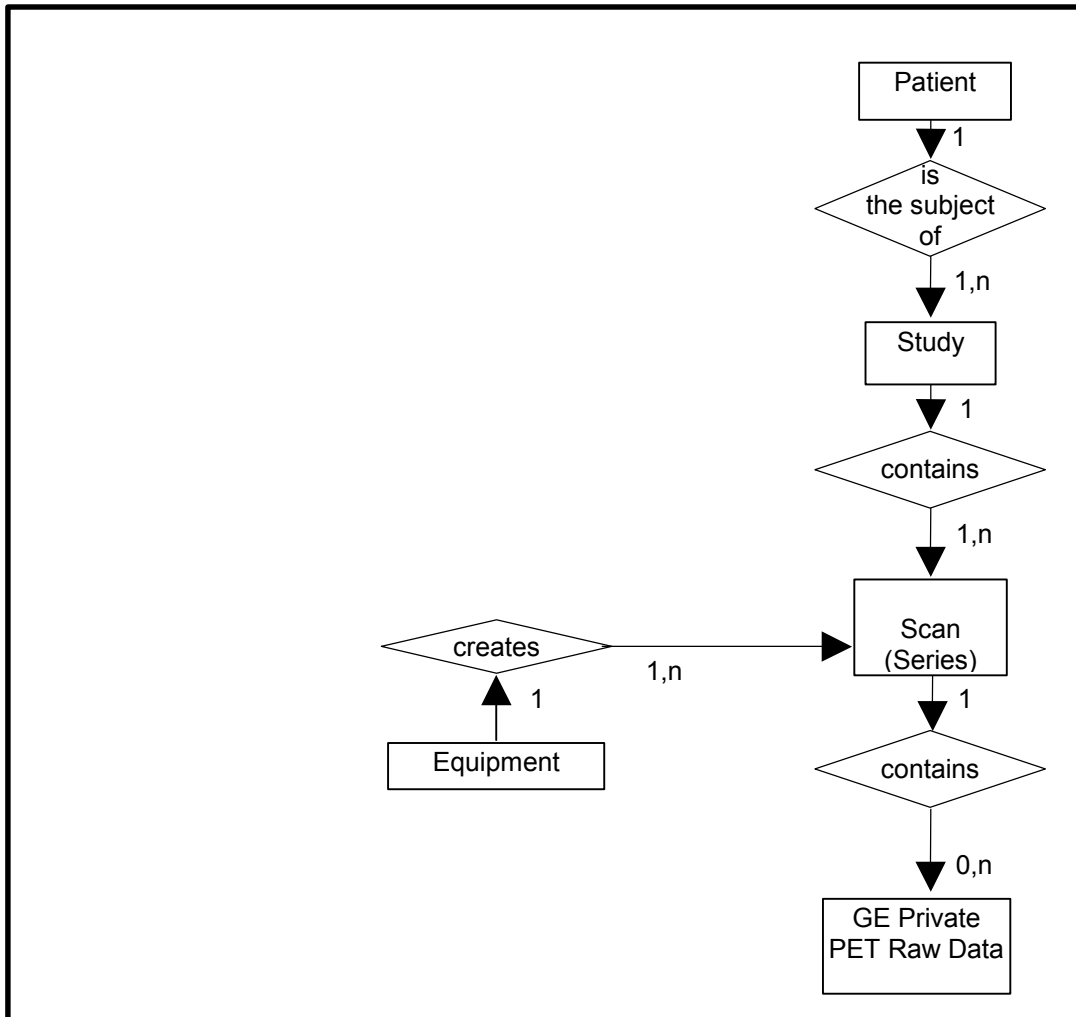

H.2.1 ENTITY DESCRIPTIONS

H.2.1.1 Patient Entity Description

The Patient Entity defines the characteristics of a patient who is the subject of one or more medical studies which produce medical images.

H.2.1.2 Study Entity Description

The Study Entity defines the characteristics of a medical study performed on a patient. A study is a collection of one or more series of medical images which are logically related for the purpose of diagnosing a patient. Each study is associated with exactly one patient.

H.2.1.3 Scan (Series) Entity Description

The Scan Entity defines the attributes which are used to group information related to one acquisition into distinct logical sets. Each series is associated with exactly one study.

H.2.1.4 Equipment Entity Description

The Equipment Entity describes the particular imaging device which produced the series of images. An imaging device may produce one or more series within a study. The Equipment Entity does not describe the data acquisition or image creation Attributes used to generate images within a series.

H.2.1.5 GE Private PET Raw Data Entity Description

GE Private PET Raw Data entity defines the attributes which describe the data pertaining to 1 'frame' of acquisition. A frame is defined by an acquisition taken at a particular Field of View (FOV), for prescribed period of time. The data contained in the frame varies with respect to the type of acquisition vis a vis, STATIC, DYNAMIC or GATED.

H.2.2 GE Discovery ST PET AE Mapping of DICOM entities

TABLE 2.4-1
MAPPING OF DICOM ENTITIES TO DISCOVERY ST PET ENTITIES

DICOM	Discovery ST PET Entity
Patient	Patient
Study	Exam
Series	Scan
Private	GE Private PET Raw data (Frame)

H.3 GE Private PET Raw Data IOD MODULE TABLE

Within an entity of the DICOM IOD, attributes are grouped into related set of attributes. A set of related attributes is termed a module. A module facilitates the understanding of the semantics concerning the attributes and how the attributes are related with each other. A module grouping does not infer any encoding of information into datasets.

Table 2.4-1 identifies the defined modules within the entities which comprise the DICOM Standalone Curve IOD. Modules are identified by Module Name.

See DICOM Part 3 for a complete definition of the entities, modules, and attributes.

TABLE 2.4-1
CURVE IOD MODULES

Entity Name	Module Name	Reference
Patient	GE Discovery ST PET RAW Data Patient	
Study	GE Discovery ST PET RAW Data Exam	
Series	GE Discovery ST PET RAW Data Scan	
Equipment	GE Discovery ST PET RAW Data Equipment	
Private	GE Discovery ST PET RAW Data Frame	
General Modules	SOP Common	

H.4 GE Private PET Raw Data INFORMATION MODULE DEFINITIONS

This section details the attributes that are present in the GE Private PET Raw Data IOD, that can be used as key information to store and retrieve the instances of the IOD. No meaning shall be assumed to other attributes whether Private or Standard that are contained in this IOD.

H.4.1 GE Discovery ST PET RAW Data Patient Entity Module

This section specifies the Attributes of the Patient that describe and identify the Patient who is the subject of a diagnostic Study. This Module contains Attributes of the patient that are needed for diagnostic interpretation of the Image and are common for all studies performed on the patient.

TABLE H.4.1-1

Attribute Name	Tag	Type	VR	VM	Discovery ST PET Attribute (Discovery ST PET Patient table unless otherwise specified)	Notes
Patient's Name	(0010,0010)	2	PN (64)	1	patient_name	
Patient ID	(0010,0020)	2	LO (64)	1	patient_identifier	
Patient's Birth Date	(0010,0030)	2	DA (26)	1	birthdate	
Patient's Sex	(0010,0040)	2	CS (16)	1	sex	

H.4.2 GE Discovery ST PET RAW Data Exam Module

This section specifies the Attributes which describe and identify the Study performed upon the Patient.

TABLE H.4.2-2

Attribute Name	Tag	Type	VR	VM	Discovery ST PET Attribute (GE Discovery ST PET Exam table unless otherwise specified)	Notes
Study Instance UID	(0020,000D)	1	UI	1	study_uid	
Study Date	(0008,0020)	2	DA	1	extract date from exam_datetime	
Study Time	(0008,0030)	2	TM	1	extract time exam_datetime	
Referring Physician's Name	(0008,0090)	2	PN	1	ref_physician	
Study ID	(0020,0010)	2	SH	1	study_identifier	
Accession Number	(0008,0050)	2	SH	1	requisition	

H.4.3 GE Discovery ST PET RAW Data Scan Entity Modules

This section specifies the Attributes which identify and describe general information about the Scan within a Study.

TABLE 2.4-3

Attribute Name	Tag	Type	VR	VM	Discovery ST PET Attribute (GE Discovery ST PET ImageSet table unless otherwise specified)	Notes
Modality	(0008,0060)	1	CS	1	Imageset.modality	
Series Instance UID	(0020,000E)	1	UI	1	Scan.scan_id	
Series Number	(0020,0011)	2	IS	1	series_number	
Operators' Name	(0008,1070)	3	PN	1-n	Exam.operator	
Patient Position	(0018,5100)	2C	CS	1	Scan.patient_position, Frame.patient_entry	

H.4.4 GE Discovery ST PET RAW Data Equipment Entity Modules

This section specifies the Attributes which identify and describe the piece of equipment which produced the instance of the Private SOP class

TABLE 2.4-4

Attribute Name	Tag	Type	VR	VM	Discovery ST PET Attribute (GE Discovery ST PET Exam table unless otherwise specified)	Notes
Manufacturer	(0008,0070)	2	LO	1	manufacturer	
Institution Name	(0008,0080)	3	LO	1	hospital_name	
Manufacturer's Model Name	(0008,1090)	3	LO	1	scanner_desc	
Software Versions	(0018,1020)	3	LO	1	Frame.software_version	

H.4.5 GE Discovery ST PET RAW Data Frame Entity Modules

Rafer to

TABLE H.4.5-5

Attribute Name	Tag	Type	VR	VM	Discovery ST PET Type
GE Discovery ST PET Frame.frame_id	(0009,105C)	3	UI	1	64A
GE Discovery ST PET Frame.table_height	(0009,1066)	3	FL	1	F
GE Discovery ST PET Frame.landmark_datetime	(0009,1068)	3	DT	1	D
GE Discovery ST PET Frame.slice_count	(0009,1069)	3	SL	1	L
GE Discovery ST PET Frame.start_location	(0009,106A)	3	FL	1	F
GE Discovery ST PET Frame.acq_delay	(0009,106B)	3	SL	1	L
GE Discovery ST PET Frame.acq_start	(0009,106C)	3	DT	1	D
GE Discovery ST PET Frame.acq_duration	(0009,106D)	3	SL	1	L
GE Discovery ST PET Frame.acq_bin_dur	(0009,106E)	3	SL	1	L
GE Discovery ST PET Frame.acq_bin_start	(0009,106F)	3	SL	1	L

H.4.6 General Modules

This section defines the Attributes which are required for proper functioning and identification of the associated SOP Instances. They do not specify any semantics about the Real-World Object represented by the IOD.

**TABLE 2.4-6
SOP COMMON MODULE ATTRIBUTES**

Attribute Name	Tag	Type	VR	VM	Discovery ST PET Attribute (GE Discovery ST PET Image table unless otherwise specified)	Notes
SOP Class UID	(0008,0016)	1	UI	1	1.2.840.113619.4.30	
SOP Instance UID	(0008,0018)	1	UI	1	Generated by the equipment	
Specific Character Set	(0008,0005)	1C	CS	1	= NULL	
Instance Creation Date	(0008,0012)	3	DA	1	current_date	
Instance Creation Time	(0008,0013)	3	TM	1	current_time	
Instance Creator UID	(0008,0014)	3	UI	1	= 1.2.840.113619.1.131.<dbcode>	